

# INSTRUCTION MANUAL

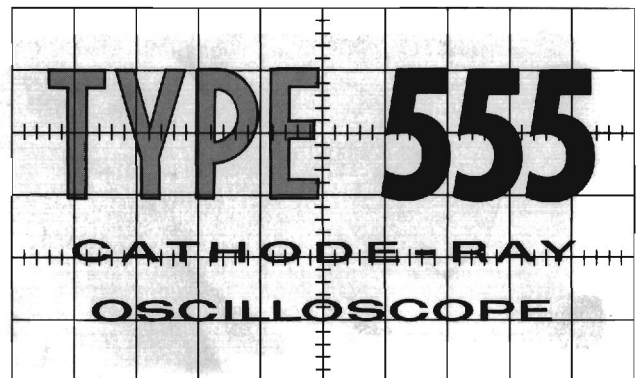

*Tektronix, Inc.*

S.W. Millikan Way ● P. O. Box 500 ● Beaverton, Oregon ● Phone MI 4-0161 ● Cables: Tektronix

*Tektronix International A.G.*

Terrassenweg 1A ● Zug, Switzerland ● PH. 042-49192 ● Cable: Tekintag, Zug Switzerland ● Telex 53.574

070-165



## **WARRANTY**

All Tektronix instruments are warranted against defective materials and workmanship for one year. Tektronix transformers, manufactured in our own plant, are warranted for the life of the instrument.

Any questions with respect to the warranty mentioned above should be taken up with your Tektronix Field Engineer.

Tektronix repair and replacement-part service is geared directly to the field, therefore all requests for repairs and replacement parts should be directed to the Tektronix Field Office or Representative in your area. This procedure will assure you the fastest possible service. Please include the instrument Type and Serial number with all requests for parts or service.

Specifications and price change privileges reserved.

Copyright © 1959. New material Copyright © 1961 by Tektronix, Inc., Beaverton, Oregon. Printed in the United States of America. All rights reserved. Contents of this publication may not be reproduced in any form without permission of the copyright owner.



## **CONTENTS**

Warranty

- Section 1 Characteristics
- Section 2 Operating Information
- Section 3 Applications
- Section 4 Theory of Operation
- Section 5 Maintenance
- Section 6 Internal Adjustments
- Section 7 Calibration Procedure
- Section 8 Accessories
- Section 9 Parts List and Diagrams

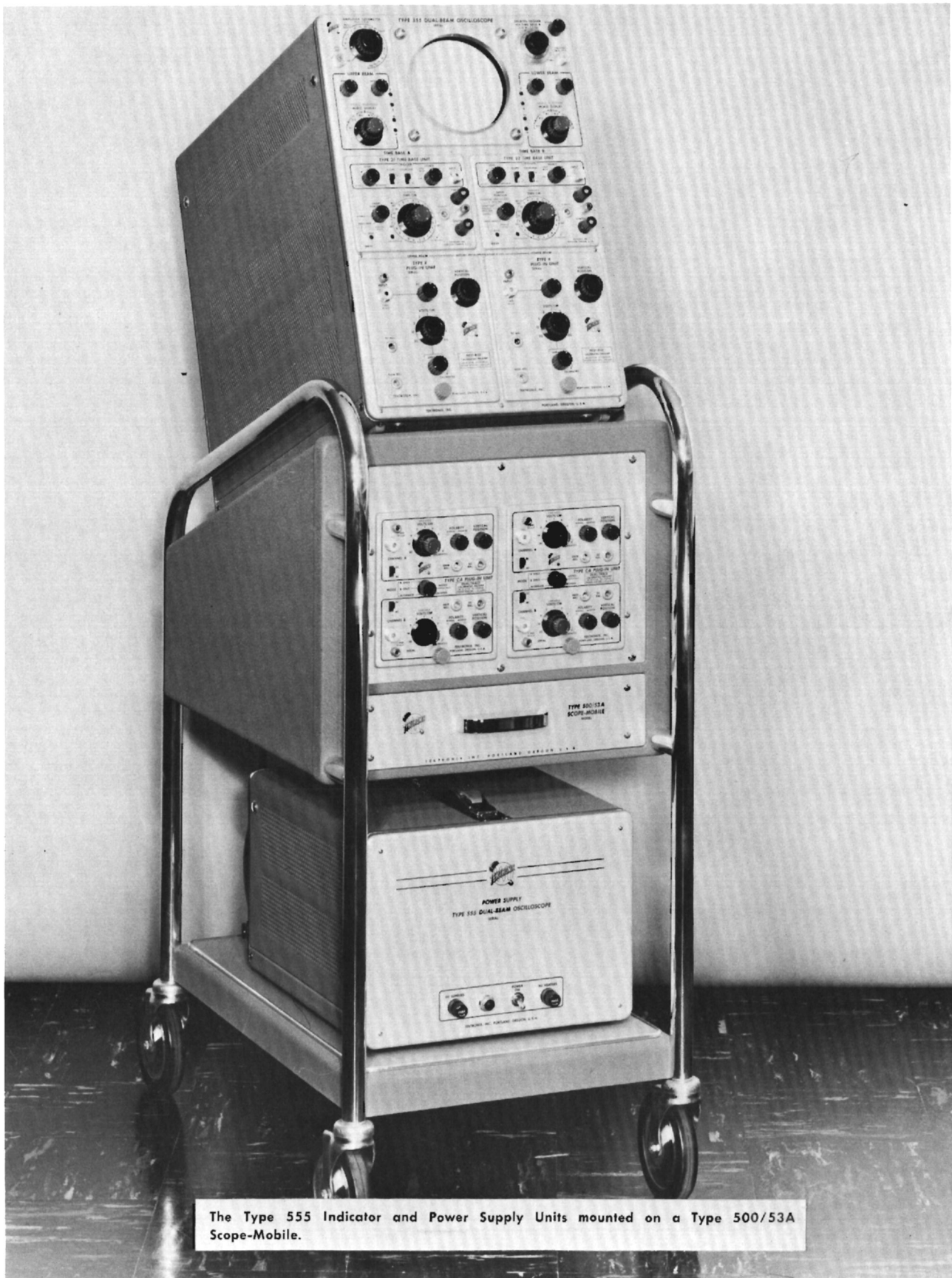

The Type 555 Indicator and Power Supply Units mounted on a Type 500/53A Scope-Mobile.

## CHARACTERISTICS

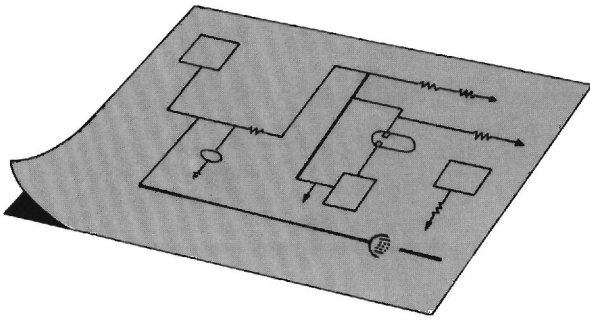

### General Information

The Type 555 Oscilloscope is a wide-range, dual-beam, laboratory instrument providing accurate measurements in the dc to 30 mc range. Two complete horizontal and vertical deflection systems permit completely independent operation of the two beams. Either of two plug-in time base units can control the sweep of either or both of the beams.

Both vertical channels utilize Tektronix plug-in preamplifier units. This plug-in unit feature permits you to select the bandpass, risetime, type of input, and sensitivity required for your application. This selection is made by choosing the proper plug-in unit for the application.

Special circuits incorporated in the Type 555 permit you to select an accurate, continuously variable, delay in presentation of one of the sweeps. The sweep may be delayed from .05  $\mu$ seconds to 50 seconds after application of a triggering pulse. This feature allows you to expand a selected portion of the undelayed sweep thereby permitting precise time measurements. Both the delayed and the undelayed sweeps are presented on the oscilloscope screen.

### Vertical-Deflection System

Characteristics for both vertical channels are identical. The actual figures depend on the plug-in units used with the instrument. The following characteristics are given assuming that Type K Plug-In units are used:

Bandpass      DC to 30 mc (3 db down at 30 mc  $\pm 1/2$  db)  
Risetime              0.012 microseconds

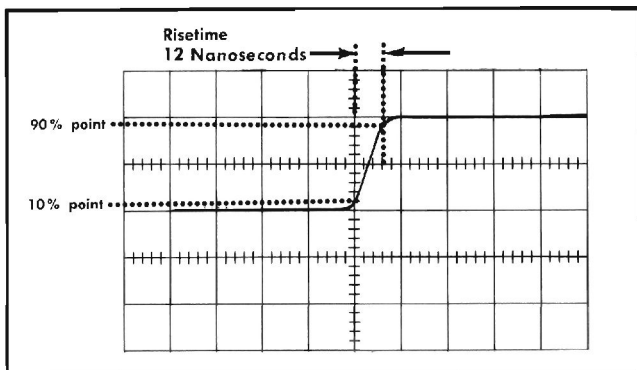

Fig. 1-1. Vertical risetime of the Type 555 Oscilloscope using a Type K Plug-In Unit.

### Triggering Modes

Time Base A and Time Base B—AC, DC, and AC Automatic.

### Triggering Signal Sources

Time Base A and Time Base B—External, Lower Beam, Upper Beam, and Line.

### Triggering Signal Requirements

Internal from Upper or Lower Beam signal—A signal producing 2 mm of vertical deflection up to 2 mc. For frequencies above 2 mc increased signal amplitude is required.

External triggering—A signal of 0.2 to 10 volts.

Sweep will trigger on larger signals, but TRIGGERING LEVEL control operates over a  $\pm 10$  volt range.

### Sweep Rates

Type 21 and Type 22—0.1 microseconds to 5 seconds per centimeter in 24 accurately calibrated steps. Uncalibrated vernier controls permit sweep rates to be varied continuously between 0.1 microseconds and approximately 12 seconds per centimeter. Calibrated sweep rates are typically within 1%, and in all cases within 3%, of the indicated sweep rate.

### Magnifiers

Displayed waveforms on either the upper or the lower beams can be expanded horizontally by a factor of 5, by means of separate sweep magnifiers. The magnifiers extend the fastest sweep rates to 0.02 microseconds per centimeter. Sweep rates are accurate to within 5% with the magnifiers on.

### External Horizontal Inputs

External signals can be applied to sweep either of the two beams. Characteristics for both beams are identical.

Deflection factors—approximately 0.2 V/CM to approximately 20 V/CM. The deflection factors are uncalibrated and continuously variable.

Passband—DC to approximately 240 KC (3 db down point) with the EXT HORIZ GAIN control in the maximum gain position.

Input impedances—approximately 47 pf paralleled by 1 megohm with the HORIZ DISPLAY control in the X1 position.

## Characteristics—Type 555

### Delayed Sweep

Sweep delay continuously variable from 0.5 microsecond to 50 seconds. Actual delay steps (between 1.00 and 10.00) are within 3% of the indicated delay from 0.5  $\mu\text{sec/cm}$  to 50  $\text{sec/cm}$ . Incremental delay accuracy is within 0.2%.

Time jitter—1 part in 20,000.

### Cathode-Ray Tube

Type T555P

Phosphors—Type P2 phosphor normally supplied; P1, P7, and P11 phosphors optional. Other phosphors available on special order.

Unblanking—dc coupled.

Accelerating potential—10,000 volts.

Usable viewing area—total of 6 centimeters with 4 centimeters for each beam. At least 2 centimeters of overlap between the two beams.

### Graticule

Illumination—variable edge lighting.

Markings—marked in 6 vertical and 10 horizontal 1-centimeter divisions with 2-millimeter markings on the centerlines.

### Amplitude Calibrator

Waveform—square-waves at approximately 1,000 cycles.

Output voltage—0.2 millivolts peak-to-peak to 100 volts peak-to-peak in 18 steps.

Accuracy—peak-to-peak amplitude of square-waves within 3% of the indicated voltage.

### Power Supplies

Electronically regulated for stable operation with widely varying line voltages and loads.

Line voltage requirements—105 to 125 volts, or 210 to 250 volts.

Power requirements—maximum of 1050 watts.

Line frequency—50 to 60 cps.

### Output Waveforms Available (see Figure 1-2)

Delayed trigger pulse—approximately 5 volts in amplitude, occurring at the end of the delay period.

+Gate A—20 volts peak-to-peak with the same duration as the A sweep.

Sawtooth A—A sweep sawtooth waveform, 150 volts peak.

+Gate B—20 volts peak-to-peak with the same duration as the B sweep.

Sawtooth B—B sweep sawtooth waveform, 150 volts peak.

### Ventilation

Forced filtered air. Thermal relay interrupts instrument power in the event of overheating.

### Construction

Aluminum-alloy chassis and three-piece cabinets. Photo-etched anodized panel, blue wrinkle-finished cabinet.

Dimensions: Indicator Unit: 24" long, 13" wide, 20" high.

Power Supply Unit: 17½" long, 13" wide, 10" high.

Weight—Indicator Unit: 68 pounds. Power Supply Unit: 45 pounds.

### Accessories

1—Time-base plug in extension (013-013).

4—P6006 Attenuator Probes (10X Attenuator), (010-127).

1—Inter-unit cable (012-032).

2—Binding-post adaptors BNC (103-033)

1—Test lead (012-031).

1—Green Filter (378-514).

1—3-conductor power cord (161-010).

2—Instruction Manuals.

1—3 to 2-wire adapter, 103-013.

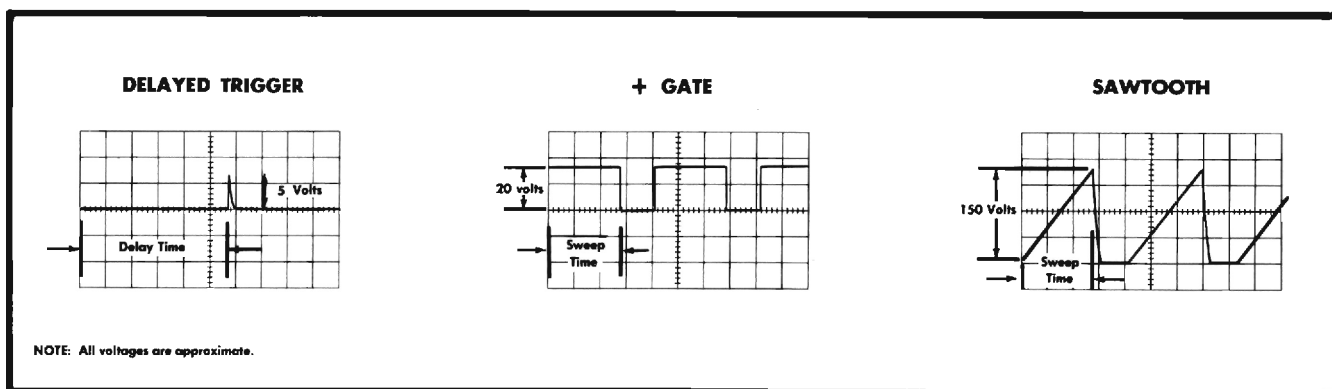

Fig. 1-2. Output waveforms available at the oscilloscope front panel.

**PLUG-IN PREAMPLIFIER CHARACTERISTICS FOR TYPE 555 OSCILLOSCOPE**

PLUG-IN TYPE	CALIBRATED DEFLECTION FACTOR	PASSBAND	RISETIME	INPUT CAPACITANCE
TYPE A Wide-Band DC Coupled	0.05 v/cm to 20 v/cm	dc to 20 mc	18 nsec	47 pf
TYPE B Wide-Band High-Gain	5 mv/cm to 0.05 v/cm 0.05 v/cm to 20 v/cm	2 c to 12 mc dc to 20 mc	30 nsec 18 nsec	47 pf
TYPE CA Dual-Trace DC Coupled	0.05 v/cm to 20 v/cm	dc to 24 mc	15 nsec	20 pf
TYPE D High-Gain DC Coupled Differential	1 mv/cm to 50 v/cm	dc to 2 mc	0.18 $\mu$ sec	47 pf
TYPE E Low-Level AC Coupled Differential	50 $\mu$ v/cm to 10 mv/cm	0.06 cycles to 60 kc	6 $\mu$ sec	50 pf
TYPE G Wide-Band DC Coupled Differential	0.05 v/cm to 20 v/cm	dc to 20 mc	18 nsec	47 pf
TYPE H DC Coupled High-Gain Wide-Band	0.005 v/cm to 20 v/cm	dc to 15 mc	23 nsec	47 pf
TYPE K Fast-Rise DC Coupled	0.05 v/cm to 20 v/cm	dc to 30 mc	12 nsec	20 pf
TYPE L Fast-Rise High-Gain	5 mv/cm to 2 v/cm 0.05 v/cm to 20 v/cm	3 c to 24 mc dc to 30 mc	15 nsec 12 nsec	20 pf
TYPE N* Pulse Sampling	10 mv/cm	600 mc	0.6 nsec	Input Impedance, 50 ohms
TYPE P* is a fast-rise step-function test signal unit.				
TYPE Q* Strain Gage	10 $\mu$ strain/div to 10,000 $\mu$ strain/div	dc to 6 kc	60 $\mu$ sec	Adjustable
TYPE R* Transistor Risetime	0.5 ma/cm to 100 ma/cm		12 nsec	
TYPE S* Semiconductor Diode Recovery	0.05 v/cm and 0.5 v/cm			
TYPE T* Time-Base Generator				
TYPE Z* Differential Comparator	0.05 v/cm to 25 v/cm	dc to 13 mc	27 nsec	27 pf

\*More data available on the special purpose plug-in units in the following paragraphs.

### Type N

The Type N Sampling Unit is designed for use with Tektronix plug-in type Oscilloscopes. The sampling system thus formed permits the display of repetitive signals with fractional nanosecond ( $10^{-9}$  second or nsec) risetime. By taking successive samples at a slightly later time at each recurrence of the pulse under observation, the Type N reconstructs the pulse on a relatively long time-base. Characteristics of the Type N include a risetime of 0.6 nsec, corresponding to a maximum bandpass of approximately 600 mc; a sensitivity of 10 mv/cm with 2 mv or less noise; and a dynamic range of  $\pm 120$  mv minimum linear range before overloading results.

Accidental overload of  $\pm 4$  volts dc is permissible.

### Type P

The Type P Plug-In Unit generates a fast rise step-function test signal of known waveform, simulating the output of an ideally compensated Type K Unit driven with a Tektronix Type 107 Square-Wave Generator. The Type P permits the standardization of the main-unit vertical amplifier transient response of a Tektronix convertible oscilloscope. Pulse repetition rate is 240 step functions per second, with either positive or negative polarity. Step function amplitude is continuously adjustable between 0 and 3 major graticule divisions.

### Type Q

The Type Q Plug-In Unit permits any Tektronix convertible oscilloscope such as the Type 555 to be operated with strain gages and other transducers. Excitation voltages for the strain gages and transducers are provided by the plug-in unit. The unit provides high gain, low noise, and extremely low drift. Frequency response of the Type Q Plug-In Unit is DC to 6 kc; risetime is approximately 60 microseconds. Strain sensitivity is calibrated in 10 steps from microstrain per major graticule division to 10,000 microstrain per division, and is continuously variable between steps.

### Type R

The Type R Plug-In Unit is a combined power supply and pulse generator which is used to measure the high-frequency characteristics of junction transistors by the pulse-response method. When the Type R is used in an oscilloscope having a delay line; delay time, risetime, storage time, and falltime may be displayed simultaneously. A pushbutton switch connects a front-panel terminal directly to the input of the oscilloscope for observing externally derived waveforms.

Pulse risetime of the Type R Unit is less than 5 nanoseconds, so measurements depend on the risetime of the oscilloscope used. Pulse amplitudes are in 8 fixed, calibrated steps from .05 to 10 volts, adjustable between steps. Pulse recurrence frequency is 120 pulses per second.

### Type S

The Type S Plug-In Unit is designed for use with Tektronix Wide-Band convertible oscilloscopes. Using the Type S, voltage across a test diode is displayed as a function of time.

Certain diode parameters, such as junction resistance, junction capacitance, and the stored charge at the junction, can be measured readily and reliably from the display. Performance of a diode in a particular circuit can be predicted by analyzing the recovery and "turn-on" characteristics. Since it is essentially a means for plotting voltage across an element while passing constant current through it, the unit can be used for other applications as well. For example: observing the junction characteristics of transistors, or measuring the resistance, capacitance or inductance of circuit components.

The Type S offers calibrated forward currents in five fixed steps from 1 to 20 milliamps, and reverse currents calibrated in six steps from 0 to 2 milliamps. Diode shunt capacitance is 9 picofarads, and deflection factors are 0.05 v/cm and 0.5 v/cm, calibrated.

### Type T

The Type T Time-Base Generator provides sawtooth sweep voltages from 0.2  $\mu$ sec/div to 2 sec/div. The trigger source may be line frequency, external, ac or dc coupled, automatic or high-frequency sync. The triggering point can be on either rising or falling slope of the waveform, and triggering level is adjustable. A signal of 0.2 volts to 50 volts is required for triggering.

### Type Z

The Type Z Plug-In Units extends the accuracy of oscilloscope voltage measurements. It can be used in three modes of operation: (1) as a conventional preamplifier, (2) as a differential input preamplifier, or (3) as a calibrated differential comparator. With sensitivity of 50 mv/cm and insertion voltage range of  $\pm 100$  volts, the effective scale range is  $\pm 2000$  cm. Maximum resolution of the Type Z Unit is .005%.

As a conventional preamplifier, the Type Z Unit offers a passband of dc to 13 mc with the Type 555 for signals that do not overscan the screen. The deflection factors are 0.05 volts/cm to 25 v/cm in 9 fixed, calibrated steps.

As a differential input preamplifier, the Type Z accepts a common-mode signal level  $\pm 100$  volts with input attenuation X1, and offers a common-mode rejection ratio of 40,000 to 1. Maximum input signal is +1 volt/7 nsec, or -1 volt/5 nsec.

As a calibrated differential comparator, the Type Z makes available three comparison voltage ranges; from zero to  $\pm 1$  volt, zero to  $\pm 10$  volts, and zero to  $\pm 100$  volts.

## SECTION 2

# OPERATING INFORMATION

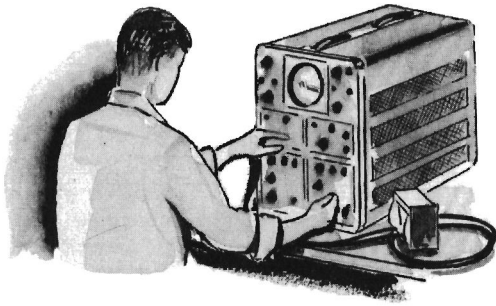

### General Information

The Type 555 Oscilloscope is a versatile instrument which is adaptable to a great number of applications. However, to make use of the full potentialities of the instrument, it is necessary for you to understand the operation and function of each of the controls. This portion of the manual provides the necessary basic operating information. Information on triggering the sweep, use of probes, input signal connections, and functions of controls are included in this section. Operation of the delayed sweep feature is covered in detail.

### Plug-In Units

The Type 555 Oscilloscope is designed to operate with Tektronix letter-series plug-in units in the vertical deflection systems. These plug-in units allow you to change the vertical characteristics of the oscilloscope to meet a wide number of applications. The particular plug-in units used must be selected by you to satisfy the requirements of your applications. In selecting the vertical plug-in units for any particular application, you must consider the bandpass, vertical risetime, sensitivity, and type of input required. The plug-in units presently available will satisfy the requirements for most applications.

Type 21 and 22 Plug-In Time Base Units are used with the Type 555 to generate the horizontal sweeps. Plug-in time base units are used primarily for ease of servicing. The plug-in extension supplied with the instrument allows either time base unit to be operated while partially withdrawn from the instrument. A Type 22 Time-Base Unit must be used for TIME BASE B in order to use the sweep delay feature. Either a Type 21 or Type 22 Time-Base Unit can be used for TIME BASE A.

The Type 555 Oscilloscope should not be used when one or more of the plug-in units is disconnected from the oscilloscope. A missing plug-in unit will not damage the oscilloscope, but may cause the power supplies to go out of regulation. Proper operation of the oscilloscope will not be obtained if the power supplies are not regulating correctly.

### Preparation For Use

When the vertical plug-ins have been selected, insert them into the plug-in compartments of the oscilloscope and press firmly to insure that the connectors make proper contact. Tighten the plug-in unit locking controls to hold the units securely in place. The location of the vertical and the Type 21 Time Base plug-in unit locking controls is shown

in Figure 2-1. The Type 22 Time Base locking control (not shown) is located on the right side of the oscilloscope indicator unit. Turn the oscilloscope INTENSITY controls fully counterclockwise. Connect the inter-unit cable to the rear of the indicator and power supply units. Connect the power cord to the rear of the power supply unit and to the power line. The metal tags located at the rear of both units indicate the operating range for which your instrument is connected. (To change the operating range, 105-125 or 210-250 VAC, refer to the 117 VAC or the 234 VAC wiring diagram in the Parts List and Schematic booklet.) Place the POWER switch in the ON position.

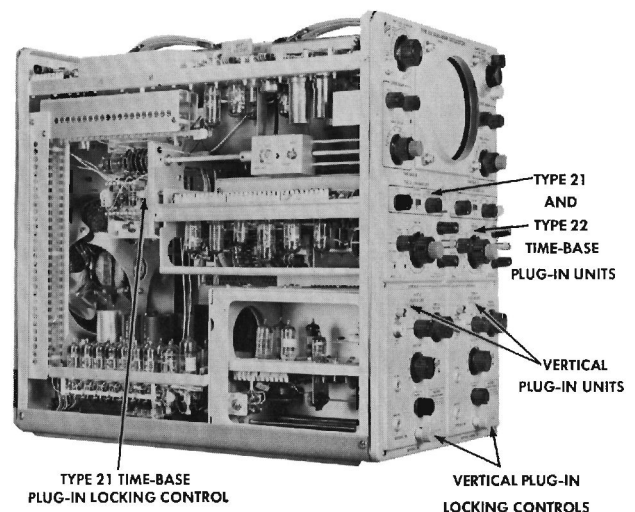

Fig. 2-1. Location of the Type 21 and vertical plug-in locking controls.

### DC Power Time Delay

The time delay relay used in the Type 555 Oscilloscope delays the operation of the instrument for approximately 30 seconds after the POWER switch is turned on to allow a brief tube-warmup period. The delay allows the tubes sufficient time to heat before the dc operating voltages are applied.

If the ac power is off for only an instant, the normal 30-second delay will occur before the instrument returns to full operation.

## Focus Controls

The focus controls allow you to obtain sharp, clearly defined spots or traces. The proper settings are obtained by adjusting the controls for a sharply focused spot or trace. If either beam does not focus properly, it may also be necessary to adjust the appropriate internal ASTIGMATISM control. The FOCUS and ASTIGMATISM controls should be adjusted simultaneously for the best possible display.

## Intensity Controls

The INTENSITY controls are used to adjust the brightness of the oscilloscope display. This permits you to compensate for changes in brightness resulting from changes in the sweep or triggering rate. The INTENSITY controls are rotated clockwise to increase brightness and counterclockwise to decrease brightness. Care must be taken when using the INTENSITY controls that the brightness is not turned up to the point where the face of the cathode-ray tube is permanently damaged. If the intensity is turned up too far, the phosphor on the face of the crt may be burned. The intensity should never be turned up to the point where a halo forms around the spot.

## Graticule Illumination Control

The graticule used with the Type 555 Oscilloscope is accurately marked with 10 horizontal and 6 vertical 1-centimeter divisions with 2-millimeter markings on the vertical centerline and on the two base lines. These graticule markings allow you to make time and voltage measurements from the oscilloscope screen.

The graticule is illuminated by two lamps located at the top edge of graticule. This illumination can be controlled so that the graticule markings appear either red or white, as desired. The graticule markings are changed from red to white or from white to red by removing the graticule cover and rotating the graticule (see Figure 2-2). As a general rule, white graticule markings are superior to red for photographic purposes. To obtain satisfactory waveform photographs, the intensity of the trace must approximately match the brightness of the graticule markings.

Graticule illumination is adjusted by the SCALE ILLUM. control. Rotating the control clockwise increases the brightness of the graticule markings and rotating the control counterclockwise decreases the brightness.

## Positioning Controls

Four controls are used with the Type 555 Oscilloscope to allow you to position the trace of both beams to the desired points on the oscilloscope screen. Two of these controls are used to set the horizontal positions of the two beams and are located on the front panel of the instrument. The other two controls are used to set the vertical positions of the two

beams and are located on the front panel of the plug-in units used with the oscilloscope. (Type CA Dual-Trace Plug-In Units have two Vertical Positioning controls.)

The two beams have independent horizontal positioning. The Upper Beam HORIZ. POSITION control positions the upper beam; the Lower Beam HORIZ. POSITION control positions the lower beam. The HORIZ. POSITION controls cause the traces to move to the right when rotated in the clockwise direction and to the left when rotated counterclockwise. The controls have sufficient range for you to view the entire trace even when the beam is expanded horizontally by a factor of 5 using the appropriate HORIZ. DISPLAY switch.

The vertical position controls have sufficient range to allow the beams to be positioned completely above or below the usable area of the screen. The traces move up when the controls are rotated clockwise and down when the controls are rotated counterclockwise.

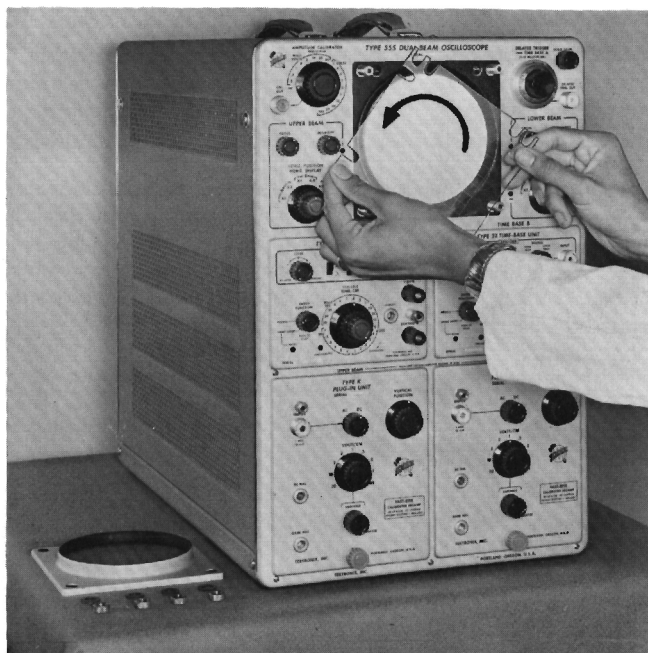

Fig. 2-2. Rotating the graticule to change the color of the graticule markings from red to white or from white to red.

## Beam Position Indicators

Four small indicator lights, located on each side of the oscilloscope screen, indicate the position of the beams. When one of these lamps is lit, it indicates that the trace is off-centered in the direction of the arrow. These lights allow you to position each beam to the center of the usable area of the screen even though the intensity is so low that the trace is not visible. When the sweep is running, the beams move from the left side of the screen to the right and may cause both horizontal lamps to light each time the sweep runs.

### Input Signal Connections

Waveforms to be displayed on the oscilloscope are connected to the input connectors of the vertical plug-in units. The signals are then amplified and used to produce vertical deflection of the electron beams. Frequently it is possible to make the necessary input connections with unshielded test leads. This is true particularly when you are observing high-level low-frequency waveforms. When test leads are used, place a ground connection between the oscilloscope chassis and the chassis of the signal source.

In many applications unshielded leads are entirely unsatisfactory for making input connections due to the pickup resulting from stray magnetic fields. In such cases, shielded cables should be used. Care must be taken that the ground conductors of the cables are connected to the chassis of both the oscilloscope and the signal source.

In high frequency work it is usually necessary to terminate signal sources and connecting cables in their characteristic impedances. Unterminated connections result in reflections in the cables and cause distortion of the displayed waveforms. A properly selected coaxial cable will serve as

the termination for the signal source. The appropriate terminating resistor or attenuation pad can then be connected to terminate the cable.

In general, a termination resistor connected at the input connector of the plug-in unit will produce satisfactory results. In some cases, however, it may be necessary to terminate cables at both ends. The need for proper terminations increases as the length of the connecting cables is increased.

In analyzing the displayed waveforms, you must consider the loading effect that the oscilloscope has on the signal source. The input resistance of the oscilloscope is 1 megohm and is usually adequate to limit low frequency loading to a negligible value. At high frequencies however, the input capacitance of the vertical plug-in unit and the distributed capacitance of input cables become important. Capacitive loading at high frequencies may be sufficient to adversely affect both the displayed waveform and operation of the signal source. Both capacitive and resistive loading can usually be limited to negligible values through use of attenuator probes.

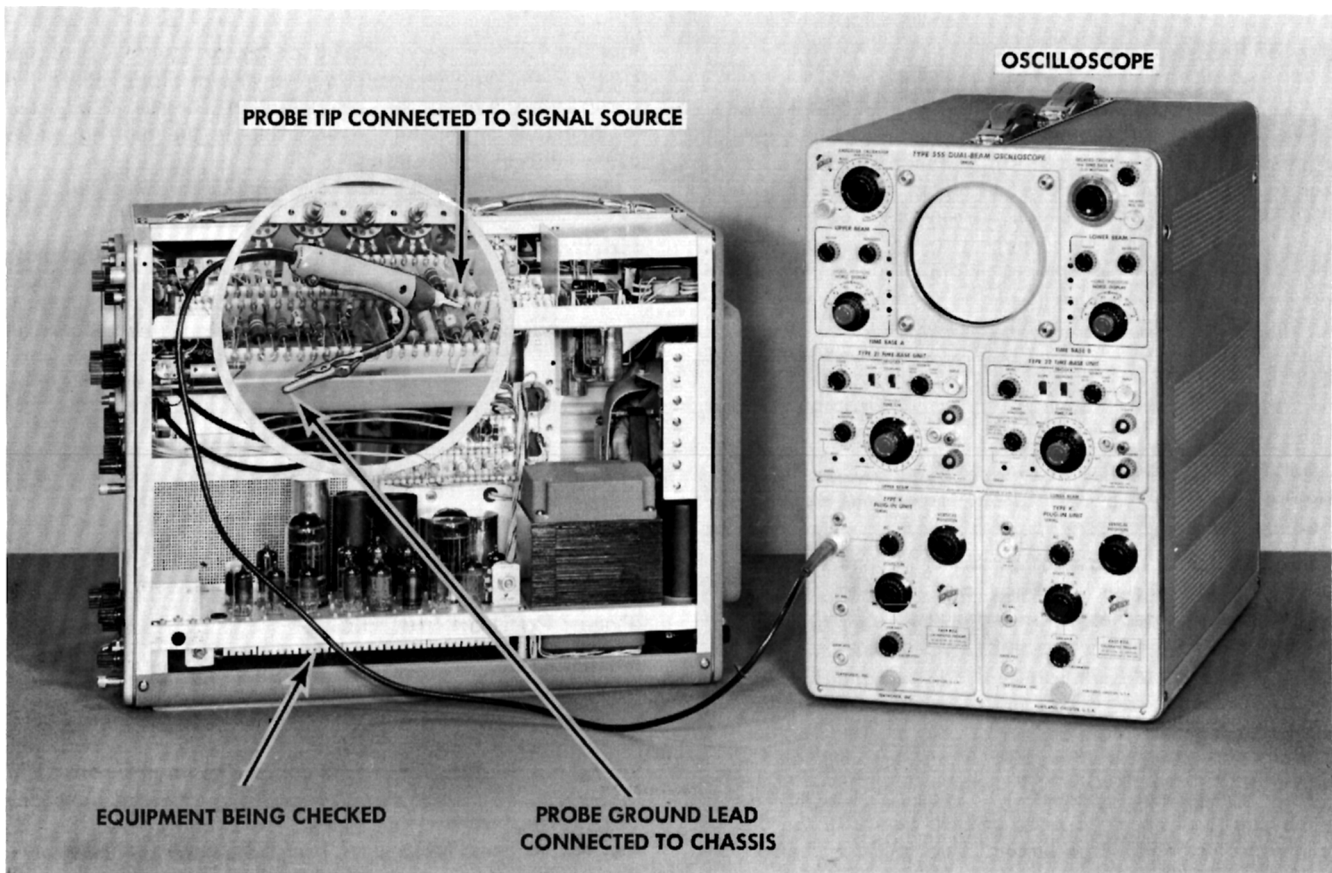

Fig. 2-3. Proper connection of a probe to the input signal source.

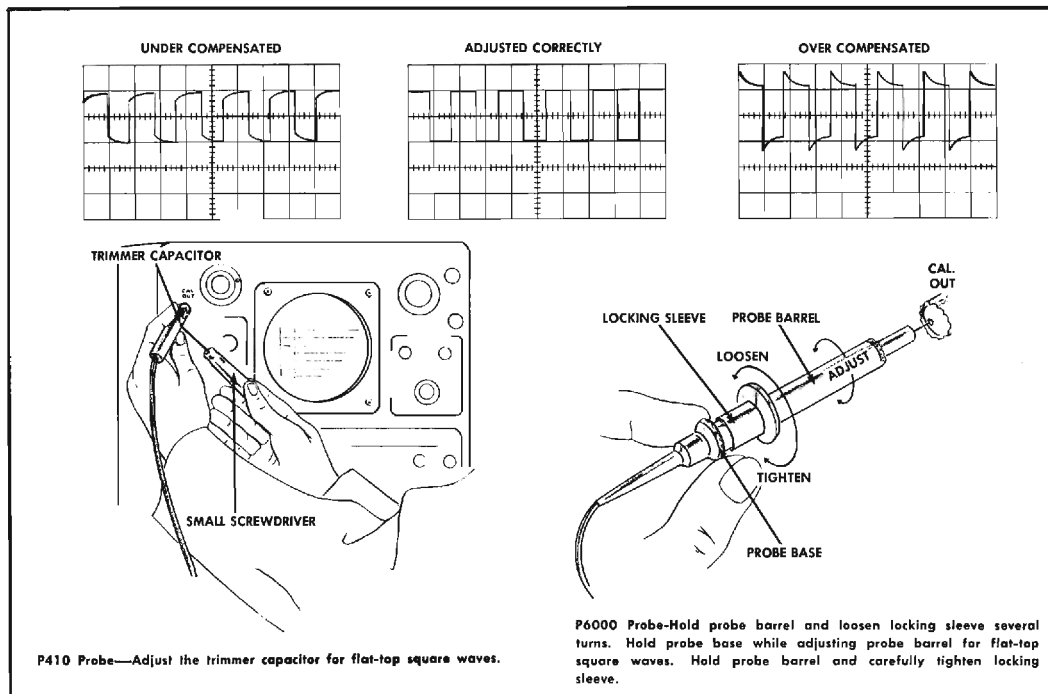

Fig. 2-4. Compensate the probe to obtain an undistorted presentation of the calibrator square-waves.

### Use of Probes

Attenuator probes reduce loading of the signal source. However, in addition to providing isolation of the oscilloscope from the signal source, an attenuator probe also decreases the amplitude of the displayed waveform by the attenuation factor of the probe. Use of a probe allows you to increase the vertical deflection factors of the oscilloscope. This permits you to observe large-amplitude signals which are beyond the normal limits of the oscilloscope and plug-in combination. Signal amplitudes, however, must be limited to the maximum allowable value for the probe used. For Type P410 probes the maximum allowable input voltage is 600 volts; maximum voltage for Type P6000 probes is 1200 volts.

**NOTE** - Type P410 probes were furnished as an accessory to the Type 555 Oscilloscope before the Type P6000 probes were available. Type P410 probes were used for the illustrations in this manual.

Before using a probe you must check (and adjust if necessary) the compensation of the probe to prevent distortion of the applied waveform. The following instructions for setting the oscilloscope controls and compensating the probe are given for UPPER BEAM and TIME BASE A operation. Place the HORIZ. DISPLAY switch at X1 and rotate the LEVEL control counterclockwise to AC AUTO. Set the SLOPE switch at +, the COUPLING switch at AC, the SOURCE switch at UPPER BEAM, and the SWEEP FUNCTION switch at NORMAL. Connect the probe tip to the CAL. OUT connector and set the AMPLITUDE CALIBRATOR switch for 2 centimeters of displayed signal. Set the TIME/CM switch to display approximately 3 or 4 cycles of the calibrator waveform and adjust the probe compensation control to ob-

tain flat tops on the displayed calibrator square-waves (see Figure 2-4). With the calibrator waveform displayed on the oscilloscope screen, the compensation control is adjusted to eliminate any distortion occurring in the leading edges of the calibrator waveforms.

### Horizontal Sweeps

Horizontal sweeps for the Type 555 Oscilloscope are produced by the two plug-in time-base units. Either beam can

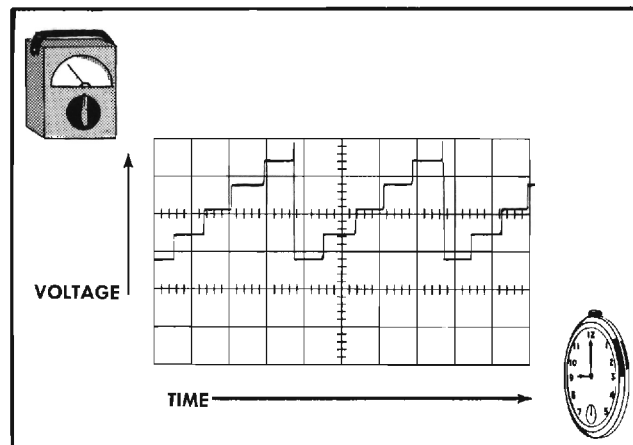

Fig. 2-5. The oscilloscope plots instantaneous voltage versus time, thereby serving both as a voltmeter and a timer. Voltage is represented by vertical deflection of the trace; time is represented by horizontal deflection. The horizontal deflection is known as the horizontal sweep.

be deflected by either time base unit. Or, if desired, both beams may be swept simultaneously by the same time base unit. The selection of time base units is made with the Upper and Lower Beam HORIZ. DISPLAY switches.

In most applications, the time base units are used with the SWEEP FUNCTION switches in the NORMAL positions. This permits normal triggered operation of the time base units. Other switch positions are used for single sweep and delayed sweep applications.

The sweep rates of the two beams are determined by the settings of the appropriate TIME/CM and HORIZ. DISPLAY switches. The sweep rate in turn determines the duration of the trigger holdoff period. The sweep characteristics of each time base unit are identical. Each time base unit provides 24 calibrated sweep rates ranging from .1  $\mu$ seconds to 5 seconds per centimeter. Uncalibrated VARIABLE TIME/CM controls permit sweep speeds to be varied continuously between .1  $\mu$ seconds and approximately 12 seconds per centimeter.

### Sweep Magnifiers

Waveforms displayed with either of the two beams can be expanded horizontally by a factor of 5 using the appropriate HORIZ. DISPLAY switch. This magnification is obtained when the HORIZ. DISPLAY switches are in either the TIME BASE A X.2 or TIME BASE B X.2 positions. The magnifiers increase the actual sweep speeds above those indicated by the TIME/CM controls. The true sweep time per centimeter is found by multiplying the settings of the TIME/CM controls by .2.

With the magnifiers on, the 2-centimeter portion at the exact center of the unmagnified display is expanded to the

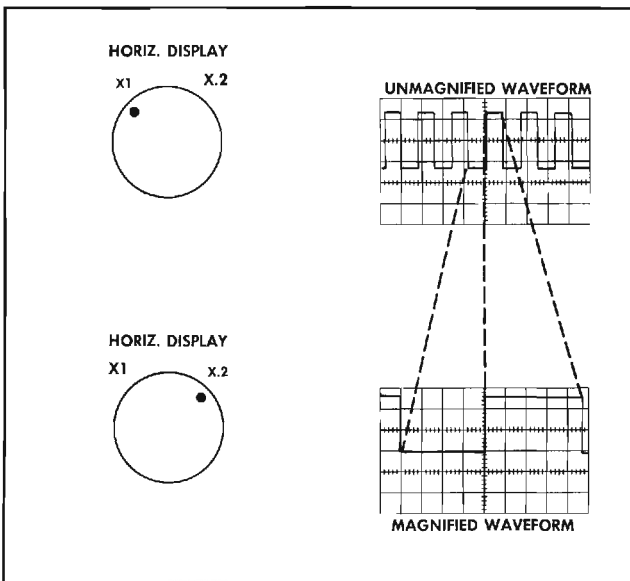

Fig. 2-6. Operation of the sweep magnifiers.

full 10-centimeter width of the graticule. Any other 2-centimeter portion of the original display can then be observed by using the HORIZONTAL POSITION control to position that portion on the screen.

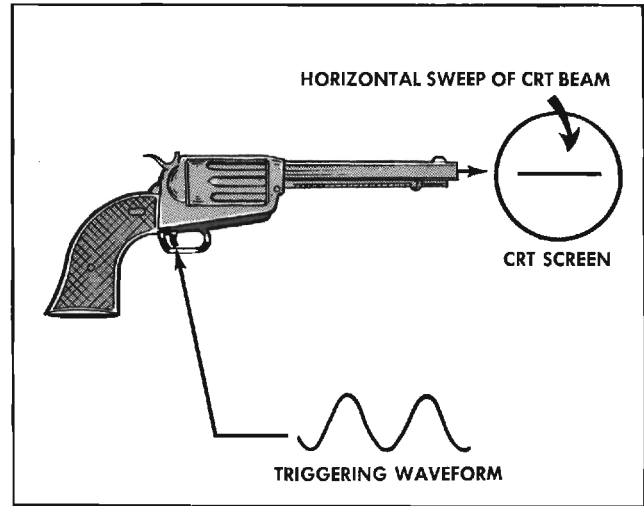

Fig. 2-7. In triggered-sweep operation the horizontal sweep of the crt beam is started by the triggering waveform.

### Sweep Triggering

The oscilloscope display is formed by the repetitive sweep of the spot across the oscilloscope screen. If the sweeps are allowed to occur at random or at a rate unrelated to the rate of occurrence of the input waveform, the displayed waveform will be traced out at a different point on the screen each time the sweep runs. This will either cause the waveform to drift across the screen or to be indistinguishable.

In most cases it is desirable for a repetitive waveform to appear stationary on the oscilloscope screen so that the characteristics of the waveform can be examined in detail. As a necessary condition for this type of display, the start of the sweep must bear a definite, fixed-time relationship to the appearance of the input waveform. This means that the sweep must be synchronized with the input waveform. In the Type 555 Oscilloscope this is accomplished by starting (triggering) the sweep with the displayed waveform or with another waveform bearing a definite time relationship to the displayed waveform.

The following paragraphs outline the means for selecting the triggering source, triggering slope, trigger input coupling, and triggering level with specific information regarding the operation of the controls affecting triggering. Triggering controls for Time Base A and Time Base B are identical so that the following information is applicable to both time-base units. Triggering of the sweep is adjusted by the respective TRIGGER LEVEL, COUPLING, SLOPE, and SOURCE controls.

### Selecting The Triggering Source

In preparing the Type 555 for triggered operation of the sweeps, it is first necessary to select the triggering signal source which will produce the desired results. Either time base unit can be triggered from the upper beam waveform, the lower beam waveform, a line frequency waveform, or from an external triggering signal. The selection of trig-

## Operating Information — Type 555

gering source is made with the appropriate SOURCE switch. Each triggering source has advantages for certain types of applications.

It is usually most convenient to trigger the sweeps internally from either the upper or lower beam signals. This is done by placing the SOURCE switch in the UPPER BEAM or LOWER BEAM position. Internal triggering is convenient since no external triggering connections are required. This method of triggering is excellent for most applications.

Triggering from the line is useful when the waveform being observed bears a definite relationship to the line frequency. This type of observation is frequently made when the displayed waveform is not suitable for triggering. When the SOURCE switch is placed in the LINE position, a constant amplitude line frequency signal is applied to the triggering circuits to insure stable operation.

Using external triggering, the triggering signal can be chosen to remain relatively constant in amplitude and shape. It is thereby possible to observe the shaping and amplification of a signal in an external circuit without resetting the oscilloscope triggering controls for each observation. Also, time and phase relationships between the waveforms at different points in the circuit can be seen. If for example, the external triggering signal is derived from the waveform at the input to a circuit, the time relationship and phase of

the waveforms at each point in the circuit are compared to the input signal by the display presented on the oscilloscope screen.

Using external triggering and a stable triggering signal, it is possible to observe and accurately measure jitter of the displayed waveform. It is difficult to make accurate jitter measurements when the sweep is triggered internally.

To trigger one of the sweeps from an external waveform, connect the triggering waveform to the appropriate TRIGGER INPUT connector. Place the SOURCE switch in the EXT. position and adjust the other triggering controls for stable triggering.

### Selecting The Triggering Slope

The horizontal sweeps can be triggered on either the rising (+slope) or falling (—slope) portion of the triggering waveform (see Figure 2-8). This selection is made with the TRIGGER SLOPE switches. In many applications the triggering slope is not important since triggering on either slope will provide a display which is suitable to the application. In other applications, however, it is important that the sweep be triggered on the proper slope in order to insure a useful display.

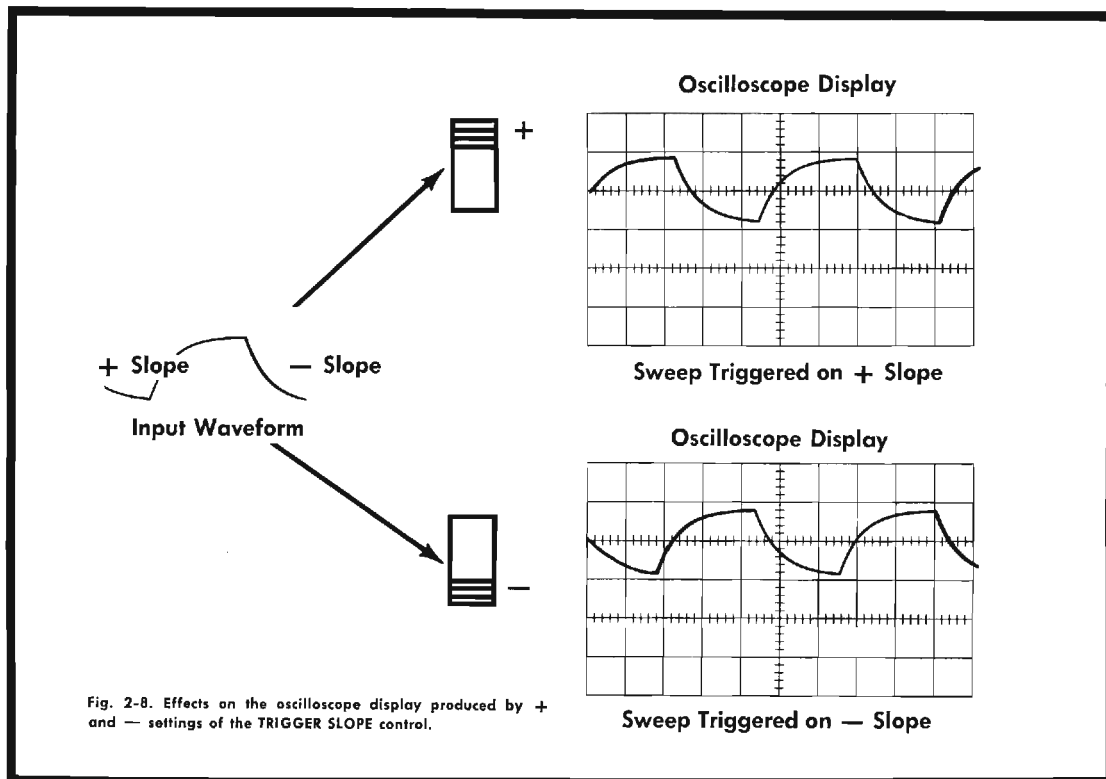
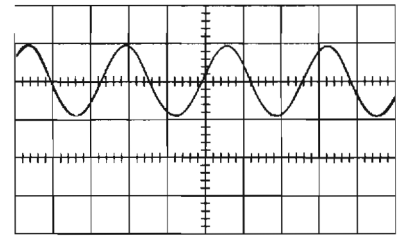
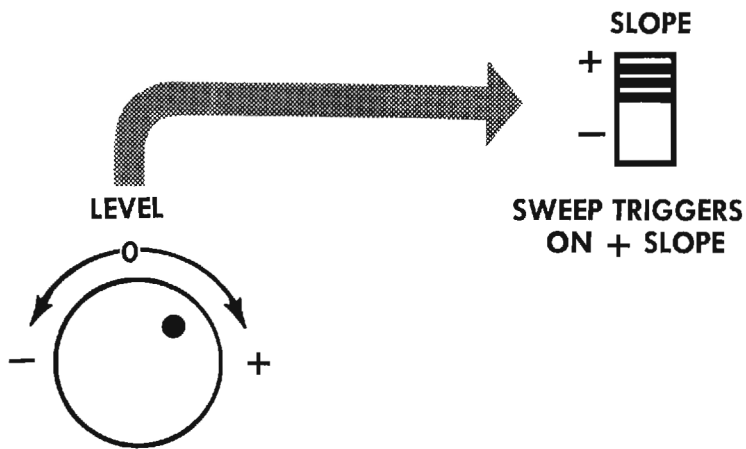
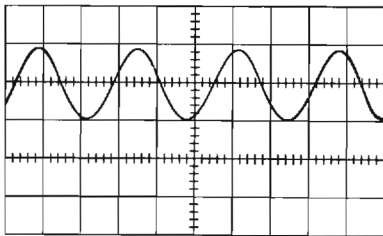
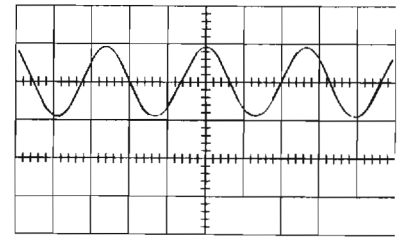
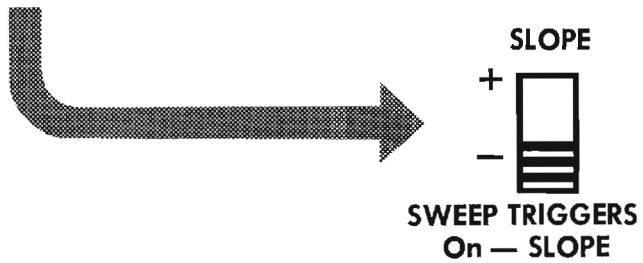

Fig. 2-8. Effects on the oscilloscope display produced by + and — settings of the TRIGGER SLOPE switches.



WAVEFORMS OBTAINED  
WITH THE LEVEL CONTROL  
SET IN THE + REGION



WAVEFORMS OBTAINED  
WITH THE LEVEL CONTROL  
SET IN THE - REGION

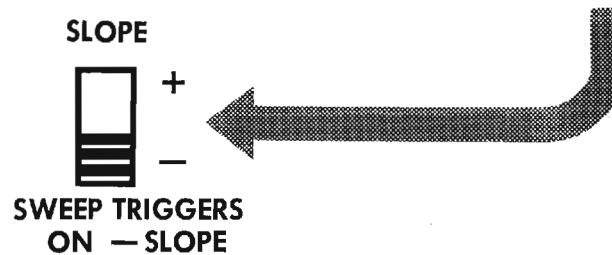
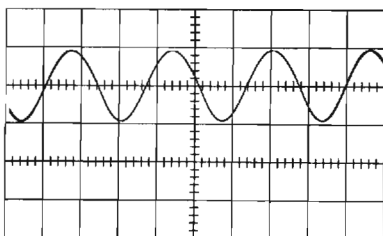
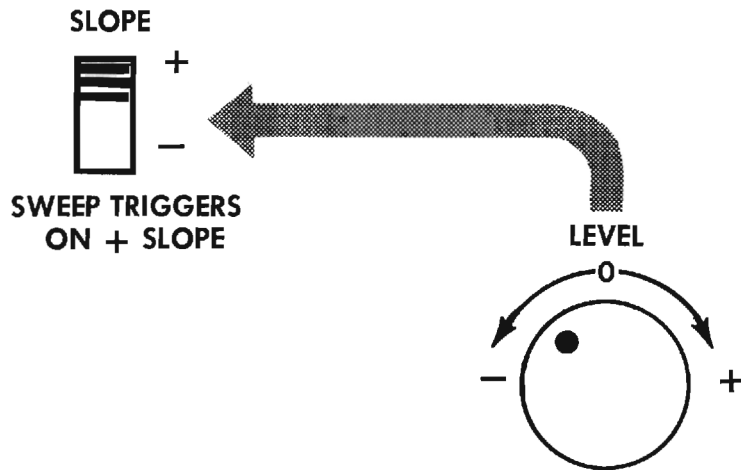

Fig. 2-9. Effects on the oscilloscope display produced by + and - settings of the TRIGGER LEVEL controls. In this illustration of the TRIGGER LEVEL control, the AC AUTO. and RECURRENT positions are not shown.

### Trigger Input Coupling

Triggering waveforms can be either ac or dc coupled into the triggering circuits depending upon the position of the TRIGGER COUPLING switch. Using ac coupling, only the ac components of the triggering signal are applied to the triggering circuits. DC coupling applies both the ac and the dc components to the triggering circuit. In general, the AC position of the TRIGGER COUPLING switch should be used. If it becomes difficult or impossible to trigger the sweep using ac coupling, dc coupling should then be used. It will be necessary for you to use dc coupling when triggering from very low frequency waveforms.

### Selection of Triggering Level

The TRIGGER LEVEL controls determine at which point on the triggering waveform triggering occurs (see Figure 2-9). Setting this control is the final step in triggering the sweep. Rotating the TRIGGER LEVEL controls in the clockwise direction causes the sweep to be triggered at more positive points on the triggering waveform. Rotating the controls counterclockwise causes the sweep to be triggered at more negative points on the waveform. In usual applications, the control is set near the zero position.

### Automatic Triggering Mode

The automatic triggering mode is most frequently used because of its ease of operation. It can be used to observe a large number of waveforms without requiring changes in settings of the triggering controls. Automatic triggering is useful for obtaining stable displays of waveforms lying in the range of approximately 60 cycles to 2 megacycles. In this mode the triggering level cannot be selected. Each sweep is instead triggered at the average voltage level of the waveform. In the absence of a triggering signal, the sweep continues to run to provide a convenient reference trace on the oscilloscope screen.

The automatic triggering mode is selected by rotating the TRIGGER LEVEL control fully counterclockwise to the AC AUTO. position. The triggering slope and source are then selected, and the input signal is applied to the oscilloscope. No other adjustments or settings of the triggering controls are required to obtain stable operation.

### Free-Running Sweep Operation

In the usual oscilloscope application, the sweep is triggered or synchronized by the input waveform. However, in some applications it may be more desirable to reverse the process and initiate the input waveform through use of a periodically recurrent waveform from the oscilloscope. In this type of application the sweep is caused to free-run and an output from either the +GATE or SAWTOOTH connector is used to trigger or synchronize the input waveform. Either Upper Beam TIME BASE A, Lower Beam TIME BASE B, or a combination of both may be used. Figure

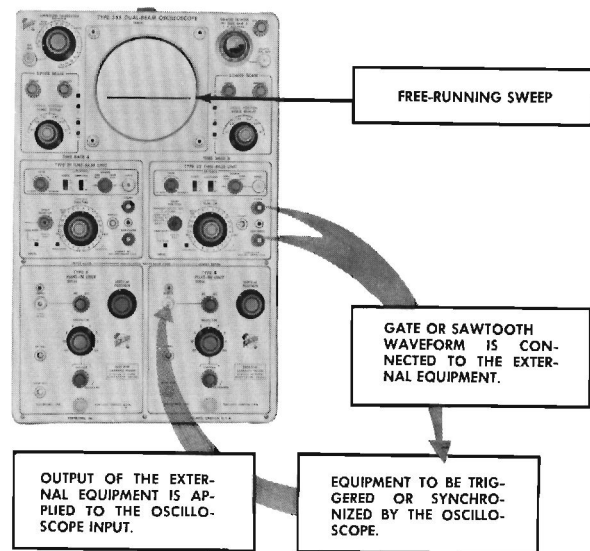

Fig. 2-10. Using the +GATE or SAWTOOTH waveform from TIME BASE B to synchronize or trigger external equipment.

2-10 shows the Lower Beam TIME BASE B method of operation.

The sweep for either time base can be made to free run by rotating the respective LEVEL control fully clockwise to the RECURRENT position. In this position the number of sweeps per second is determined by the setting of the TIME/CM controls.

In addition to providing the means for controlling an applied waveform, a free-running sweep also provides a convenient reference trace on the oscilloscope screen without requiring an input signal. This trace can then be used to position the sweep or to establish a voltage reference line.

### Delayed Sweep

In the Type 555, Time Base A can be used to delay the start of a sweep by Time Base B for a period of from .05  $\mu$ seconds to 50 seconds. Both the delayed and the undelayed sweeps can then be displayed on the oscilloscope screen. In the normal application the undelayed sweep is displayed on the upper beam; the delayed sweep is displayed on the lower beam. These conditions can be reversed however if desired by changing the positions of the HORIZ. DISPLAY switches.

Basically the delayed sweep feature of the Type 555 permits you to automatically start the sweep by Time Base A, wait a definite period of time, then start the sweep by Time Base B. This delay is continuously variable and is accurate to within 3% of the indicated delay. The delayed sweep by Time Base B allows you to examine a portion of the 'A' sweep presentation under high magnification. The magnification is the ratio of the 'A' TIME/CM switch setting to the 'B' TIME/CM switch setting. A portion of the 'A' sweep presentation is brightened to indicate the start and duration of the delayed sweep with respect to Time Base A.

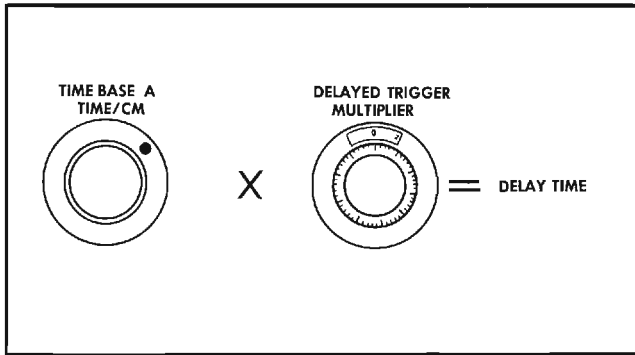
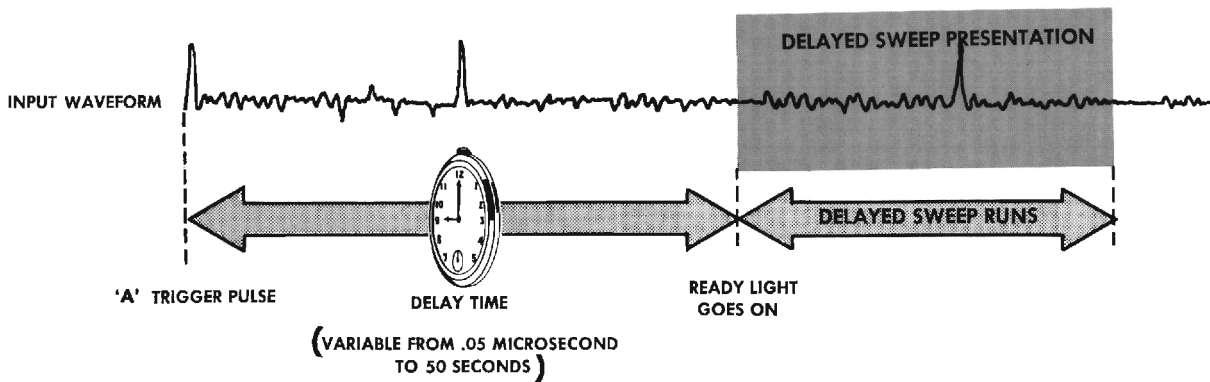

Fig. 2-11. Calculating delay time.

The delay period is determined by the settings of the 'A' TIME/CM and DELAYED TRIGGER controls. The delay time is found by multiplying the setting of the 'A' TIME/CM control by the setting of the DELAYED TRIGGER control (see Figure 2-11). For example, if the 'A' TIME/CM switch is set at 1 MILLISEC and the vernier dial of the DELAYED TRIGGER control indicates 6.75, the delay time is 6.75 milliseconds.

There are essentially two modes of delayed sweep operation (see Figure 2-12). The desired mode is selected by the setting of the Time Base B SWEEP FUNCTION control. One mode of operation is obtained with the SWEEP FUNCTION control in the SWEEPS ONCE FOR EACH "A" DEL'D TRIG. position. In this mode, the delayed sweep occurs immediately at the end of the delay period. This permits a continuously variable delay in the presentation of the sweep. Rotating the DELAYED TRIGGER control clockwise increases the delay time and causes the brightened portion of the sweep to move to the right. The size of the brightened portion of the sweep can be increased or decreased with the 'B' TIME/CM control. Through the use of both the DELAYED TRIGGER and the 'B' TIME/CM controls, any portion of the undelayed sweep can be included in the brightened section. This brightened portion is then expanded to the full width of the screen on the other beam (see Figure 2-13). The amount of magnification is the ratio of the 'A' TIME/CM control setting to the 'B' TIME/CM control setting. For example, if the 'B' TIME/CM switch is set at 1 MILLISEC and the 'A' TIME/CM switch is set a 1 SEC, the brightened portion of the sweep is magnified horizontally 1,000 times. Using this method, practical sweep magnifications up to approximately 10,000 times are attainable.

CASE 1: SWEEPS ONCE FOR EACH 'A' DEL'G TRIG.



CASE 2: TRIGGERABLE ONCE FOR EACH 'A' DEL'D TRIG.

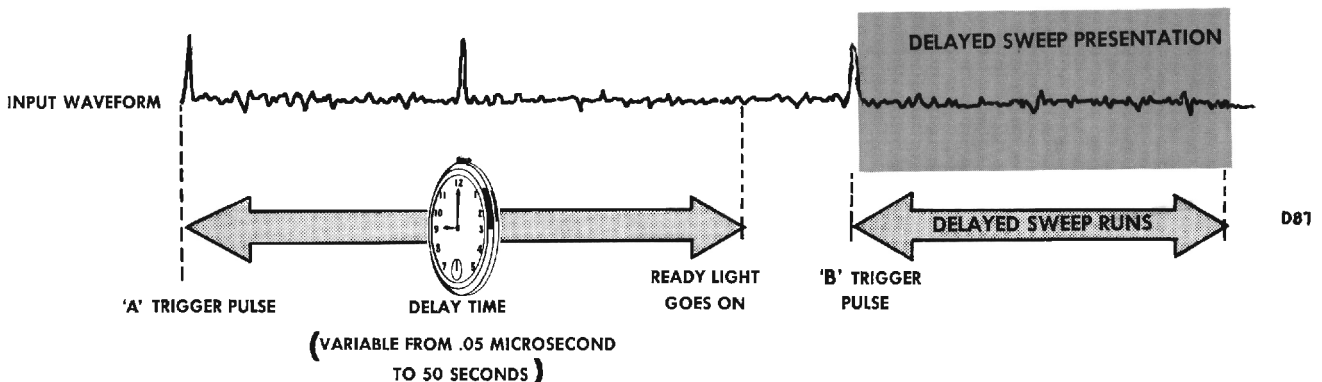

Fig. 2-12. Comparison of the two delayed-sweep modes. In each case the waveform shown represents the input to the oscilloscope. The waveform shown in the delayed-sweep presentation boxes repre-

sents the portion of the input waveform that is actually displayed on the oscilloscope screen. Note that in Case 1 an additional triggering pulse is required before the delayed sweep will occur.

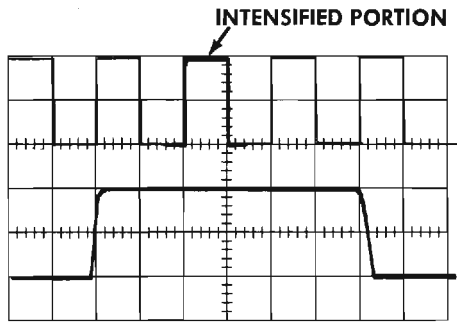

Fig. 2-13. The intensified portion of the upper beam is expanded and displayed on the lower beam.

The second delayed sweep mode is obtained with the Time Base B SWEEP FUNCTION switch in the TRIGGERABLE ONCE FOR EACH 'A' DEL'D TRIG. position. In this position the 'B' sweep is disabled for the period of delay. However, at the completion of the delay period the sweep will not occur until a triggering pulse is applied to Time Base B. The actual delay time in this mode is not continuously variable and is dependent not only on the settings of the delay-time controls, but on the occurrence of the Time Base B triggering signal as well. The TRIGGER LEVEL control must be in the position required for normal triggered operation. At the completion of the delay time, the ready light will go on to indicate that the sweep is ready to be triggered. When the triggering signal appears, the sweep runs and the READY light goes out.

### Delayed Trigger

A delayed triggering pulse can be obtained from the DELAYED TRIG. OUT connector of the oscilloscope any time from .05 microseconds to 50 seconds after the start of a

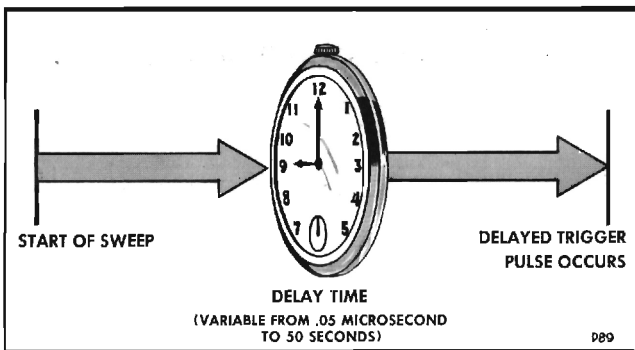

Fig. 2-14. Occurrence of the delayed triggering pulse. The delay time is adjusted with the DELAYED TRIGGER control. The delayed triggering pulse occurs at the end of the delay time.

sweep. When the oscilloscope is set for delayed sweep operation, the delayed triggering pulse can be used to initiate some action after a known time interval, and when used with the delayed sweep, the delayed trigger permits you to observe the resulting action.

To obtain a delayed trigger at the DELAYED TRIG. OUT connector, you must first adjust the TIME BASE A unit for triggered or for free-running operation, depending upon the application. The delay is then set and controlled by the 'A' TIME/CM control and the DELAYED TRIGGER control. The duration of this delay time is equal to the product of the settings of these two controls as shown previously in Figure 2-11.

### Single-Sweep Operation

The usual oscilloscope display formed by repetitive sweep is satisfactory for most applications. However, in applications where the displayed waveform is not repetitive or varies in amplitude, shape, or time interval, a repetitive sweep produces a jumbled display. When observing a waveform of this type, it is usually advantageous to use a single-sweep presentation.

Both time base units in the Type 555 Oscilloscope are equipped to produce a single-sweep presentation. Also it is possible to obtain a single-sweep display using the same time base unit to deflect both beams. The single-sweep feature permits you to display one sweep and to eliminate all subsequent sweeps. In this way, information

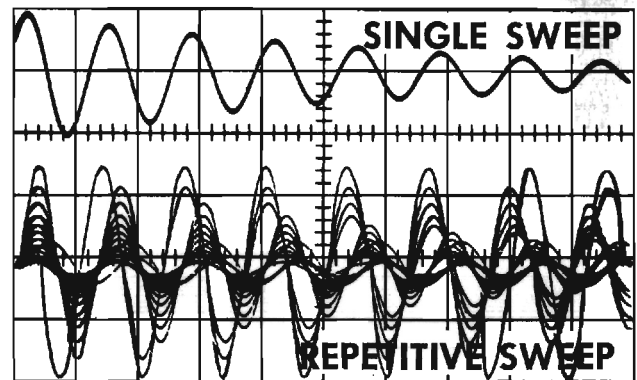

Fig. 2-15. Comparison of single sweep and repetitive sweep presentation of a damped sine wave. In the single sweep presentation the damped sine wave can be clearly seen.

is clearly recorded without the confusion resulting from multiple traces. Single-sweeps are selected with each time base unit by placing the SWEEP FUNCTION switches in the SINGLE SWEEP position.

The PUSH TO RESET buttons control the start of the sweep. When the TRIGGER LEVEL control is in the RECURRENT or AC AUTO. positions, the single-sweep occurs immediately each time the PUSH TO RESET button is depressed. When the TRIGGER LEVEL control is set for triggered operation, the single-sweep does not occur after the PUSH TO RESET button is depressed until a triggering signal is applied to the time

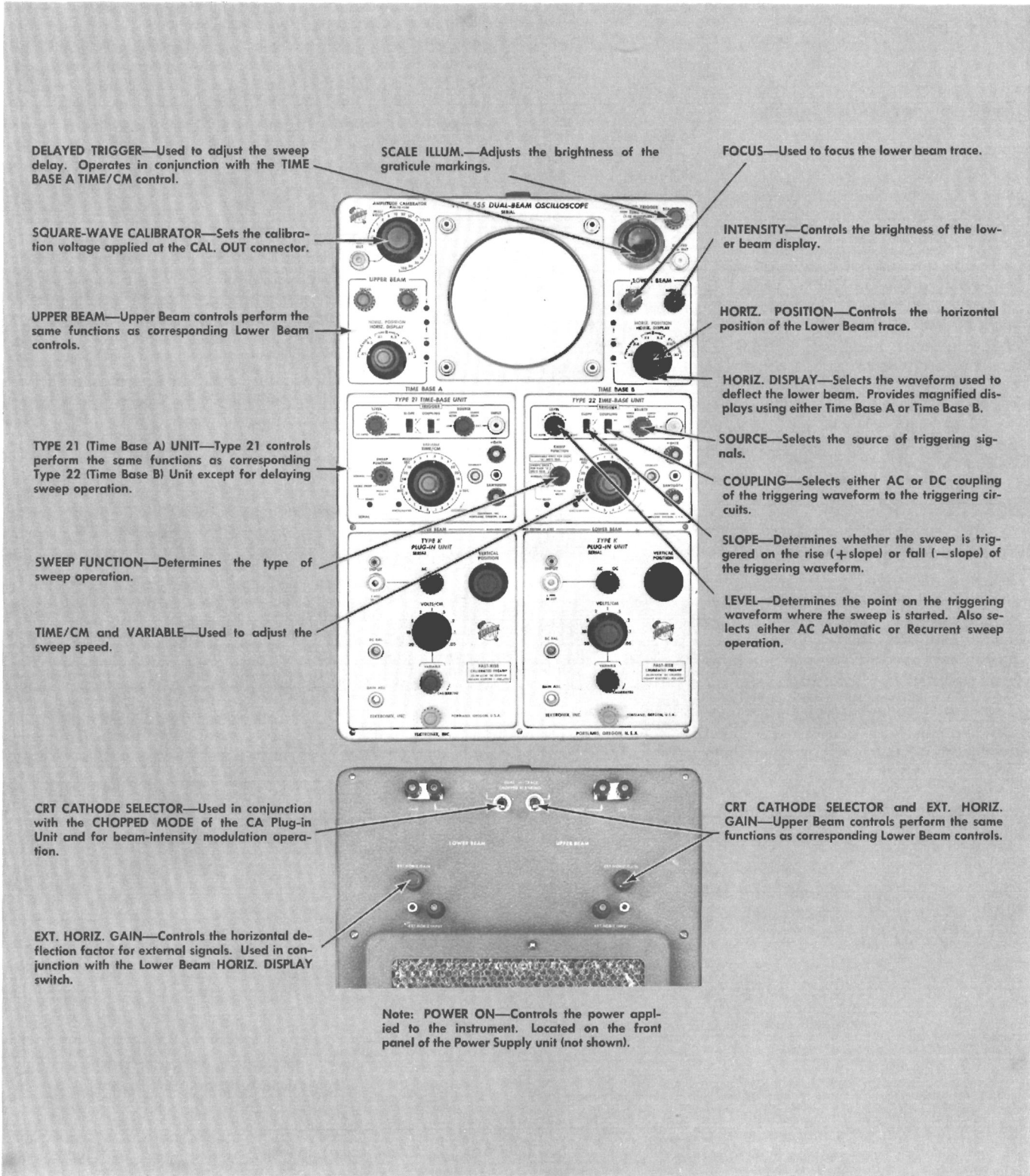

Fig. 2-16. Functions of the Type 555 Oscilloscope front and rear panel controls.

## Operating Information — Type 555

base unit. Instead the READY lamp lights to indicate that the sweep can be triggered. When a triggering signal occurs, the sweep runs and the READY light goes out. This procedure is repeated each time the PUSH TO RESET button is depressed.

### External Horizontal Inputs

For special applications you can deflect either beam horizontally with some externally derived waveform. This permits you to use the oscilloscope to plot one function versus another. The bandpass of the horizontal amplifier is dc to approximately 240 kc.

To use an external horizontal input, connect the external waveform to the EXT. HORIZ. INPUT connector for either the upper or lower beam. These connectors are located on the rear of the oscilloscope. Place the appropriate HORIZ. DISPLAY switch in one of the EXT. ATTEN. positions. The horizontal deflection produced by the external waveform can be either increased or decreased through use of the HORIZ. DISPLAY and EXT. HORIZ. GAIN controls. The horizontal deflection factors are continuously variable from approximately .2 to 20 volts per centimeter with the use of these two controls.

### Amplitude Calibrator

The amplitude calibrator provides a convenient source of square-waves of known amplitude at a frequency of approximately 1 kc. The square-waves are used primarily to adjust probes and to verify the calibration of the vertical deflection systems of the oscilloscope.

Calibrator square-waves are adjustable from .2 millivolts, peak-to-peak, to 100 volts, peak-to-peak, in 18 steps. The amplitude is controlled by the setting of the AMPLITUDE CALIBRATOR switch. The output is accurate within 3% of the AMPLITUDE CALIBRATOR switch setting when the output is connected to a high impedance load.

### Dual-Trace Plug-In Units

Type CA Dual-Trace Plug-In Units can be used to obtain either 3 or 4 separate traces when used in conjunction with the Type 555 Oscilloscope. The number of traces depends upon whether one or two dual-trace plug-in units are used. The Type CA Unit operates on a time sharing basis in which sweep time is equally divided between the upper and lower traces of each beam. The CA units can be made to sweep alternately a lower and an upper trace. Or, if desired, a chopped mode permits rapid switching back and forth from upper to lower trace. Detailed instructions for operation of the Type CA Unit are contained in the CA Unit Instruction Manual.

When Type CA Units are used in the chopped mode, switching transients are displayed on the oscilloscope screen. These undesirable transients can be blanked so that they are not visible by placing the appropriate Cathode Selector switch in the DUAL-TRACE CHOPPED BLANKING position. These switches are located on the rear of the instrument. For normal applications, the switches are placed in the CRT CATHODE position and the binding posts jumpered to ground.

### Intensity Modulation

Either beam of the Type 555 Oscilloscope can be intensity modulated by an external signal to display additional information. This is done by connecting the external signal to the appropriate CRT CATHODE connector on the rear of the instrument and placing the Cathode Selector switch in the CRT CATHODE position. This is done after first removing the grounding strap from the CRT CATHODE connector.

When you wish to make very accurate time measurements from the crt display, you can intensity modulate the beam with time markers and make your measurements directly from the time markers displayed on the screen. A positive signal of approximately 25 volts is required to cut off the beam from normal intensity.

# SECTION 3

## APPLICATIONS

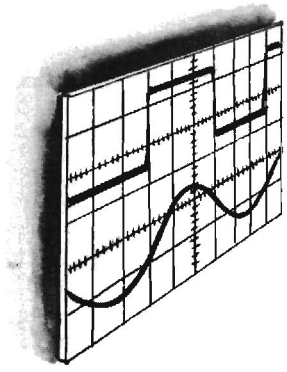

used for one reading, it should be used for all succeeding readings. The VARIABLE VOLTS/CM control must be in the CALIBRATED position.

### Voltage Measurements

The Type 555 Oscilloscope can be used to measure the voltage of the input waveform by using the calibrated vertical-deflection factors of the instrument and associated plug-in unit for each beam. The method used for all voltage measurements is basically the same although the actual techniques vary somewhat depending on the type of voltage measurements required. Essentially there are two types of voltage measurements: ac-component voltage measurements and instantaneous voltage measurements with respect to some reference potential. Many waveforms contain both ac and dc voltage components. It is often necessary to measure one or both of these components.

When making voltage measurements, you should display the waveform over as large a vertical portion of the screen as possible for maximum accuracy. Also, it is important that you do not include the width of the trace in your measurements. You should consistently make all measurements from one side of the trace. If the bottom side of the trace is

### AC Component Voltage Measurements

To measure the ac component of a waveform displayed by one of the beams, the plug-in unit input selector switch should usually be set to one of the AC positions. In these positions only the ac components of the input waveform are displayed on the oscilloscope screen. However, when the ac component of the input waveform is of very low frequency it is necessary for you to make voltage measurements with the input selector switch in one of the DC positions to prevent errors.

To make a peak-to-peak voltage measurement on the ac component of a waveform, perform the following steps (see Figure 3-1):

1. With the aid of the graticule, measure the vertical distance in centimeters from the positive peak to the negative peak.

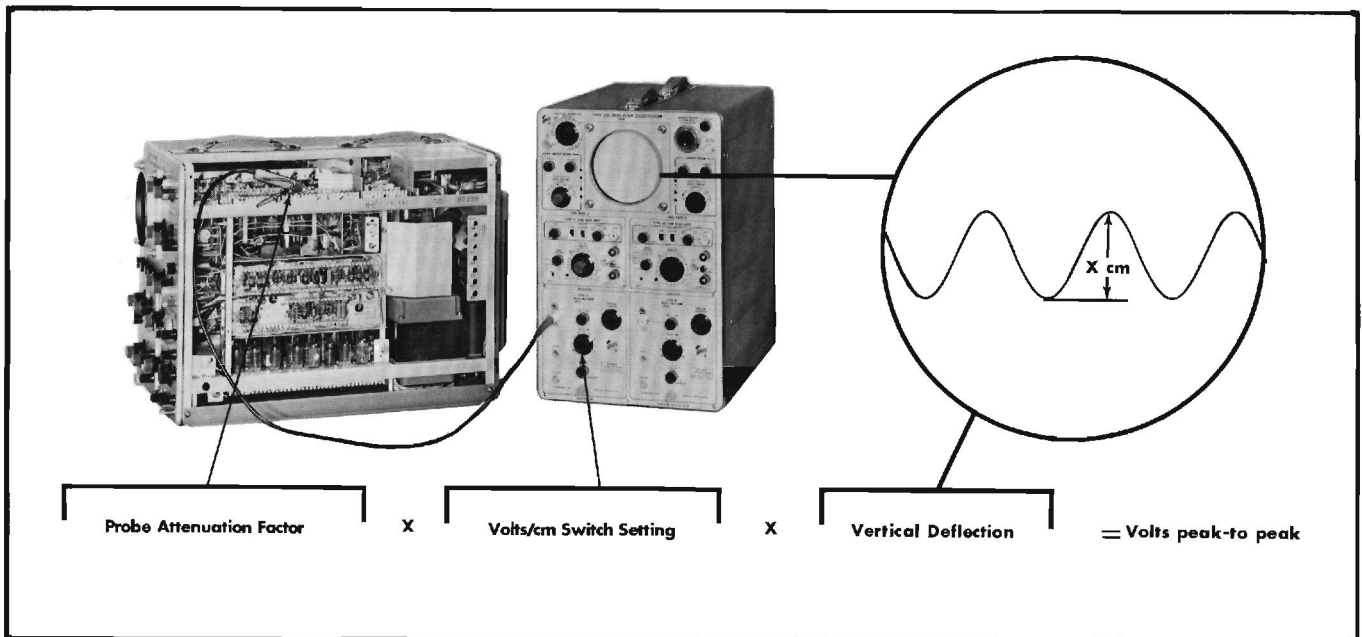

Fig. 3-1. Measuring the peak-to-peak ac component voltage of an applied waveform.

## Applications — Type 555

2. Multiply the vertical distance measured by the setting of the plug-in unit VOLTS/CM control to obtain the indicated voltage.
3. Multiply the indicated voltage by the attenuation factor of the probe to obtain the actual peak-to-peak voltage.

As an example of the method, assume that using a 10X probe and a deflection factor of 1 volt per centimeter, you measure a vertical distance between peaks of 4 centimeters. In this case then, 4 centimeters multiplied by 1 volt per centimeter gives you an indicated voltage of 4 volts peak-to-peak. The indicated voltage multiplied by the probe's attenuation factor of 10 then gives you the true peak-to-peak amplitude of 40 volts.

When sinusoidal waveforms are measured, the peak-to-peak voltage obtained can be converted to peak, rms, or average voltage through use of standard conversion factors.

## Instantaneous Voltage Measurements

The method used to measure instantaneous voltages is virtually identical to the method described previously for the measurement of the ac components of a waveform. However for instantaneous voltage measurements the plug-in unit input selector switch must be placed in one of the DC positions. Also since instantaneous voltages are measured with respect to some potential (usually ground) a reference line must be established on the oscilloscope screen which corresponds to that potential. If, for example, voltage measurements are to be made with respect to +100 volts, the reference line would correspond to +100 volts. In the following procedure the method is given for establishing this reference line as ground since measurements with respect to ground are by far the most common type. The same general method may be used to measure voltage with re-

spect to any other potential, however, so long as that potential is used to establish the reference line.

To obtain an instantaneous voltage measurement with respect to ground, perform the following steps (see Figure 3-2):

1. To establish the voltage reference line, touch the probe tip to an oscilloscope ground terminal (or if the reference line is to represent a voltage other than ground, to a source of that voltage) and adjust the oscilloscope controls to obtain a free-running sweep. Vertically position the trace to a convenient point on the oscilloscope screen. This point will depend on the polarity and amplitude of the input signal, but should always be chosen so that the trace lies along one of the major divisions of the graticule. The graticule division corresponding to the position of the trace is the voltage reference line and all voltage measurements must be made with respect to this line. (Do not adjust the vertical positioning control after the reference line has been established.)
2. Remove the probe tip from ground and connect it to the signal source. Adjust the triggering controls for a stable display.
3. Using the graticule, measure the vertical distance in centimeters from the desired point on the waveform to the voltage reference line.
4. Multiply the setting of the VOLTS/CM control by the distance measured to obtain the indicated voltage.
5. Multiply the indicated voltage by the attenuation factor of the probe you are using to obtain the actual voltage with respect to ground (or other reference voltage).

As an example of this method, assume that you are using a 10X probe and deflection factor of .2 volts per centimeter. After setting the voltage reference line at the bottom division of the graticule using the lower beam, you measure a distance of 3 centimeters from the reference line to the

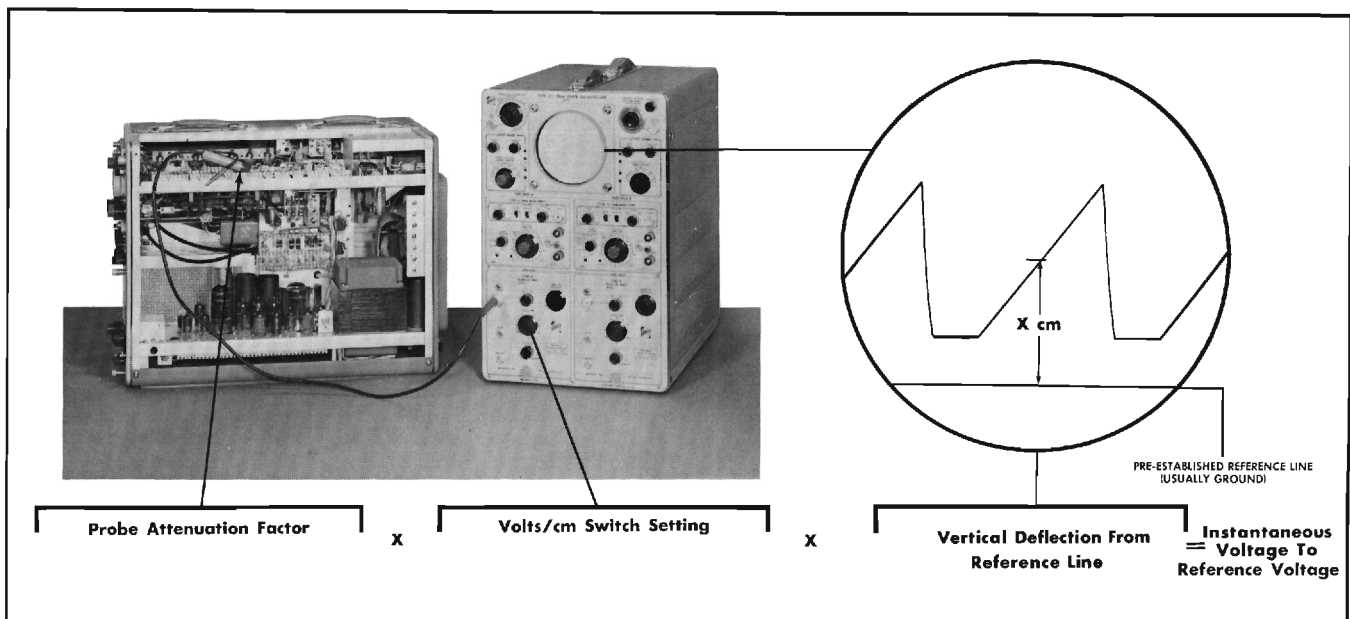

Fig. 3-2. Measuring the instantaneous voltage with respect to ground (or some other reference voltage).

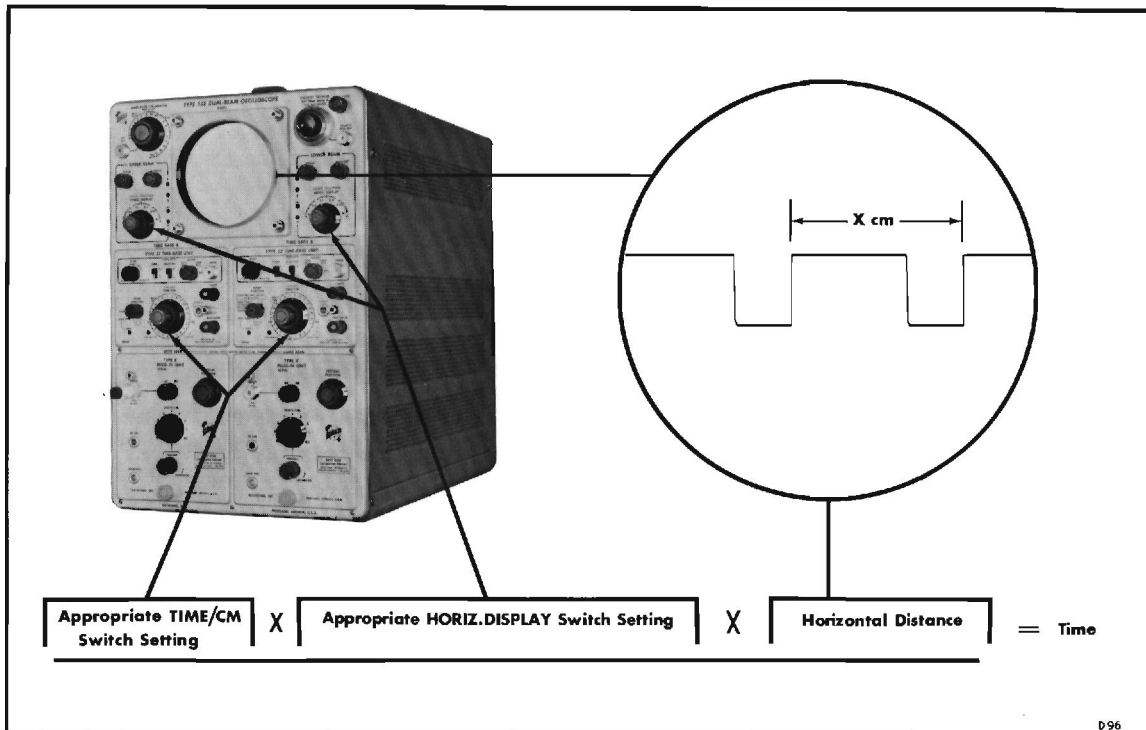

Fig. 3-3. Measuring time interval between events displayed on the oscilloscope screen.

point you wish to check. In this case 3 centimeters multiplied by .2 volts per centimeter gives you an indicated .6 volts. Since the voltage point is above the voltage reference line the polarity is indicated to be positive. The indicated voltage multiplied by the probe's attenuation factor of 10 then gives you the actual voltage of positive 6 volts.

### Time Measurements

The calibrated sweeps of the Type 555 Oscilloscope cause any horizontal distance on the screen to represent a definite known interval of time. Using this feature you can accurately measure the time lapse between two events displayed by either trace on the oscilloscope screen. One method which produces sufficient accuracy for most applications is as follows (see Figure 3-3):

1. Using the graticule, measure the horizontal distance between the two displayed events on one trace whose time interval you wish to find.
2. Multiply the distance measured by the setting of the appropriate TIME/CM control to obtain the apparent time interval. (The VARIABLE TIME/CM control must be in the CALIBRATED position).
3. Multiply the apparent time interval by .2 if the X.2 position of the HORIZ. DISPLAY is used, and 1 if the X1 position is used, to obtain the actual time interval.

For example, assume that the TIME/CM switch setting is 1 MILLISEC, the HORIZ. DISPLAY switch setting is X.2, and that you measure a horizontal distance of 5 centimeters between events displayed by the trace. In this example then,

5 centimeters multiplied by 1 millisecond per centimeter gives you an apparent time interval of 5 milliseconds. The apparent time multiplied by .2 then gives you the actual time interval of 1 millisecond.

A second method for measuring time intervals involves the use of both beams and the delayed sweep feature of the Type 555 Oscilloscope. In this method the signal source is connected to both vertical amplifier inputs. The 'B' SWEEP FUNCTION switch is placed in the SWEEPS ONCE FOR EACH "A" DEL'D TRIG. position to brighten a portion of the upper beam and to expand that portion on the lower beam. This method provides high sweep magnification for measuring on the lower beam while displaying the unmagnified waveform on the upper beam. This method is summarized as follows:

1. Connect the signal source to the Upper Beam and Lower Beam vertical amplifier input connectors.
2. Place the 'B' SWEEP FUNCTION switch in the SWEEPS ONCE FOR EACH "A" DEL'D TRIG. position.
3. Set the 'A' TRIGGER LEVEL control at AC AUTO, and place the 'A' TRIGGER SOURCE control in the UPPER BEAM position.
4. Turn the upper beam intensity down until the brightened portion of the trace is easily distinguishable. Adjust the 'B' TIME/CM control to reduce the brightened area and rotate the DELAYED TRIGGER control to cover the portion of the display you wish to measure.

\* Used throughout the text as an abbreviation for TIME BASE B.

\*\* Used throughout the text as an abbreviation for TIME BASE A.

## Applications — Type 555

5. Multiply the setting of the 'B' TIME/CM control by the horizontal distance between events displayed on the lower beam.
6. Multiply the results obtained by either 1 or 0.2 depending on the setting of the HORIZ. DISPLAY switch.

A third method for measuring time intervals involves the use of the upper beam and the delay feature. The lower beam is used to magnify and to monitor the brightened portion. This method provides a very high degree of accuracy when care is taken in making the measurements. The procedure is given as follows:

1. Connect the signal source to the Upper Beam and Lower Beam vertical amplifier input connectors.
2. Place the 'B' SWEEP FUNCTION switch in the SWEEPS ONCE FOR EACH "A" DEL'D TRIG. position.
3. Set the 'A' TRIGGER LEVEL control at AC AUTO. and place the 'A' TRIGGER SOURCE control in the UPPER BEAM position.
4. Turn the upper beam intensity down until the brightened portion of the trace is easily distinguishable. Adjust the 'B' TIME/CM control to reduce the brightened area to a small spot or to cover as small a portion of the trace as possible.
5. Using the DELAYED TRIGGER control, position the start of the brightened portion to the beginning of the interval you wish to measure. Record the setting of the DELAYED TRIGGER control.

6. Using the DELAYED TRIGGER control, position the start of the brightened portion of the trace to the end of the interval you wish to measure. Again record the setting of the DELAYED TRIGGER control.

7. Subtract the first DELAYED TRIGGER control setting from the second and multiply the result by the setting of the 'A' TIME/CM control. The figure obtained is the time interval between the two events.

## Frequency Measurements

Using one of the three methods described in the previous section, you can measure the period (time required for one cycle) of a recurrent waveform. The frequency of the waveform can then easily be calculated since frequency is the reciprocal of the period. For example, if the period of a recurrent waveform is accurately measured and found to be 0.2 microseconds, the frequency is the reciprocal of 0.2 microseconds, or 5 mc.

At any given oscilloscope sweep speed, the number of cycles of the input waveform that is displayed on 10 centimeters of the screen is dependent on the frequency of the input waveform. At a sweep speed of .1 microseconds per centimeter, for example, 6 cycles are displayed with a 6 mc input signal, 5 cycles with a 5 mc signal, and 4 cycles with a 4 mc input signal. By utilizing the pattern of these observations you can measure frequencies by counting the

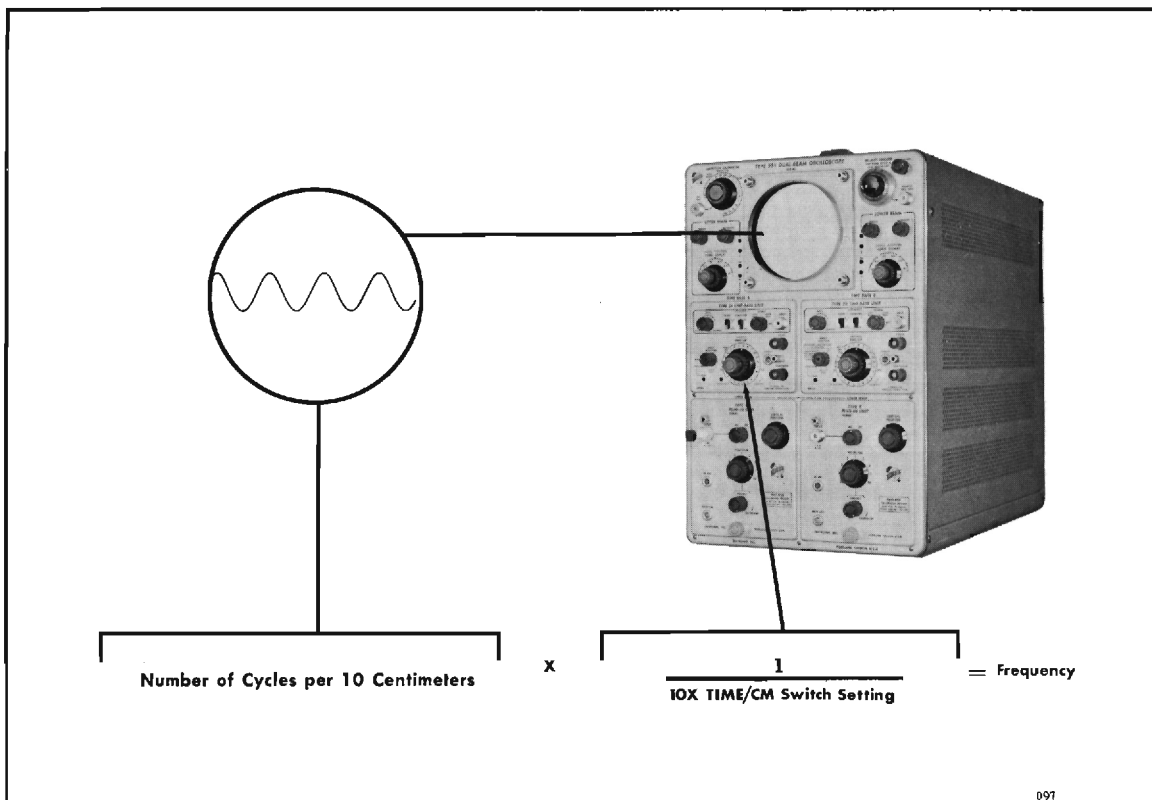

Fig. 3-4. Measuring the frequency of a repetitive input signal.

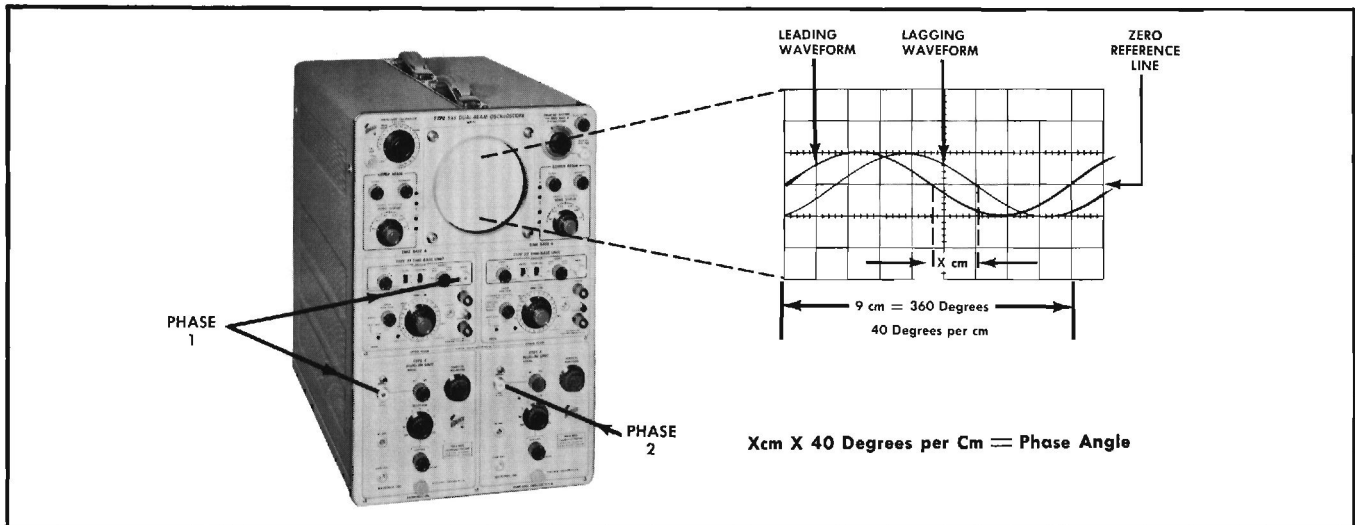

Fig. 3-5. Measuring the phase angle between two signals.

number of cycles of a waveform on 10 centimeters of the screen and multiplying this number by a factor which is dependent on the sweep speed used. Since each sweep speed produces a definite fixed multiplication factor, frequencies can usually be measured by this method much faster than by the previous method. The method is summarized as follows (see Figure 3-4):

1. Adjust the appropriate TIME/CM control to display several cycles of the input waveform. Insure that the VARIABLE TIME/CM control is in the CALIBRATED position.
2. Count the number of cycles of the waveform that are displayed on the 10 centimeters of the graticule.
3. Multiply this number by the multiplication factor for the sweep speed you are using. The product is the frequency of the input waveform.

#### NOTE

The multiplication factor for each sweep speed is found by taking the reciprocal of 10 times the sweep time per centimeter.

As an example, assume that when you are using a sweep speed of 50 milliseconds per centimeter, you count 7.2 cycles in 10 centimeters. The multiplication factor for a sweep speed of 50 milliseconds per centimeter is the reciprocal of 500 milliseconds (10 times 50 milliseconds), or 2 per second. The frequency is 7.2 cycles multiplied by 2 per second, or 14.4 cycles per second.

### Phase Measurements

Phase-angle measurements, using both beams, can be made easily by allowing a 9-centimeter width of the horizontal graticule line to represent 360 degrees. Each centimeter would then represent 40 degrees. A typical setup for

phase measurements using this method is shown in Figure 3-5. Examples of circuits that can be tested are amplifiers, transformers and filters. To make the phase measurements:

1. Select the coaxial cables and terminations to be used in your phase measurements.
2. Place both HORIZ. DISPLAY switches in the 'A' X1 position. Set the 'A' trigger controls at AC AUTO., +SLOPE, AC COUPLING, and EXT. SOURCE.
3. Set the 'A' SWEEP FUNCTION switch at NORMAL and position both traces to the middle horizontal graticule line. The middle graticule line is the zero reference line.
4. Connect the Phase 1 waveform to the 'A' vertical input connector and to the 'A' trigger INPUT connector. Connect the Phase 2 signal to the 'B' vertical input connector.

5. Adjust the 'A' TIME/CM switch and the 'A' VARIABLE TIME/CM control so that one cycle of the input waveform covers exactly 9 centimeters. Adjust both upper and lower beam vertical VOLTS/CM controls for a 2-centimeter peak-to-peak amplitude of both waveforms. Rotate the 'A' LEVEL control clockwise until the leading waveform starts at the zero horizontal reference line and horizontally position both waveforms to the left to start at the first vertical graticule line.

6. Measure the horizontal distance in centimeters between the leading waveform and the lagging waveform at the zero reference line. Multiply the horizontal distance times 40 degrees to obtain the phase angle in degrees.

To make precision phase angle measurements of a few degrees, the sine wave can be expanded horizontally by a factor of 2 or more by increasing the time base rate. The vertical sensitivity can be increased to allow an accurate intercept reading. Using this method, for example, if the time base rate is increased by a factor of 10, the new calibration rate is 4 degrees per centimeter.

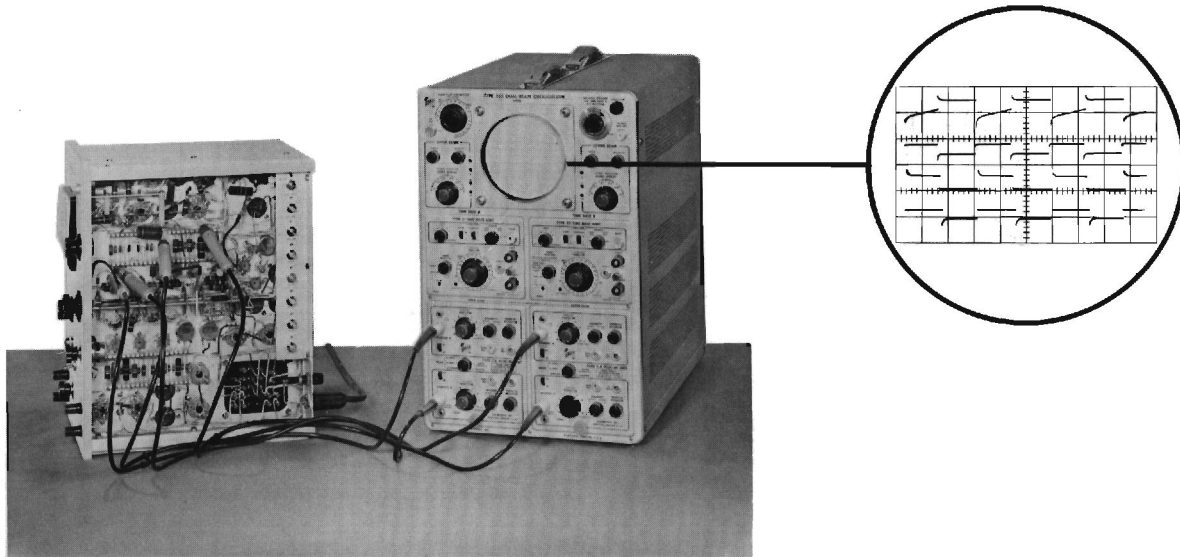

Fig. 3-6. Four trace operation using two Type CA Dual-Trace Plug-In Units.

### Four Trace Operation With Dual-Trace Plug-In Units

A four-channel display is available through the use of the time-sharing characteristics of the Type CA Dual-Trace Plug-In Units in both vertical plug-in compartments of the Type 555 Oscilloscope.

The Type CA Unit can be used to perform three types of operation; the observation of repetitive waveforms, of signal

transients, and of one waveform superimposed upon the other. Maximum flexibility is obtained by providing separate positioning, sensitivity, and polar-inverting controls for each channel.

In figure 3-6 four signals are displayed on the screen of the Type 555 Oscilloscope to demonstrate the versatility of the instrument. The MODE switch is set at the ALTERNATE position on both of the Type CA Units. For further information on the use of the Type CA Unit, refer to the Instruction Manual for that unit.

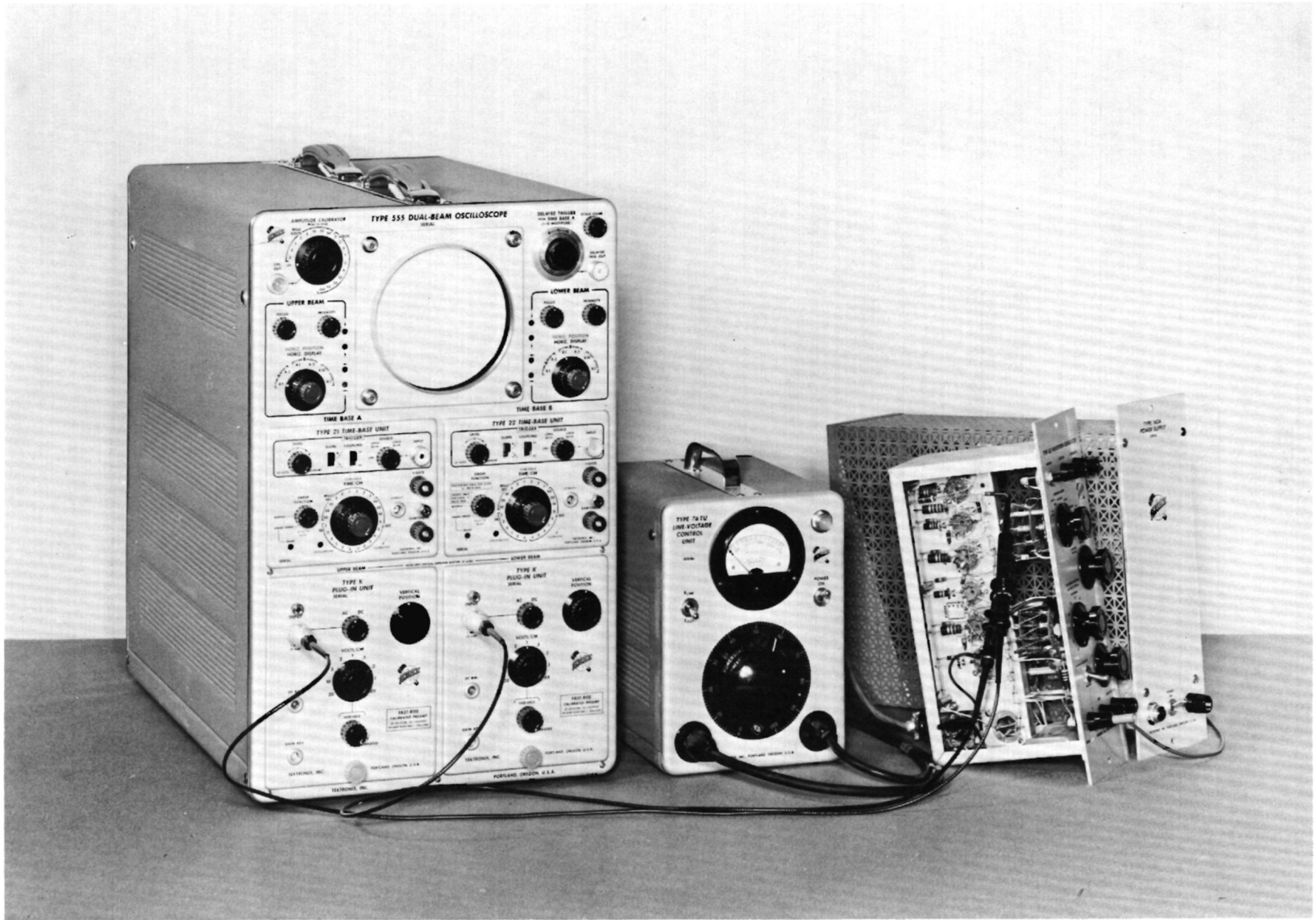
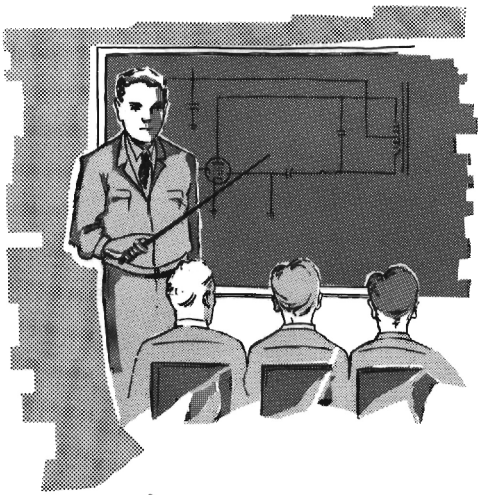

Fig. 3-7. Using the Type 555 to check the coincidence of fast-rise pulses.



## SECTION 4

# THEORY OF OPERATION

### General Information

This portion of the Operator's Manual presents a brief discussion of the Type 555 Oscilloscope's circuit operation. This discussion is keyed to various block diagrams inserted with the text and to detailed circuit diagrams in the Parts List and Schematic Diagram Booklet. Emphasis is placed on the interrelation of circuits rather than on detailed operation.

### Instrument Operation

The simplified block diagram of Fig. 4-1 illustrates the interrelation of the various circuits composing the Type 555 Oscilloscope. The instrument has identical vertical deflection systems, one for the Upper Beam and one for the Lower. The input waveforms to the oscilloscope can be connected to either or both vertical amplifiers. The waveforms are then amplified in the plug-in units and vertical amplifiers. The push-pull outputs of the vertical amplifiers are connected through delay lines to their respective vertical-deflection plates.

Trigger pickoff circuits in the Upper and Lower Beam vertical amplifiers apply a sample of the input waveforms to both trigger circuits. These waveform samples can then be used to start or synchronize the sweep of either or both time-base units. In addition, an external waveform or line-frequency waveform can also be used to trigger the sweep.

Signals of widely varying shapes and amplitudes are applied to the two trigger circuits. The trigger circuits in turn produce constant amplitude output pulses which are used to start the horizontal sweeps at the proper instant of time to insure a stable display of the input waveform.

The output pulses from the two trigger circuits are applied to their corresponding time-base generators to initiate sweep sawtooth waveforms. The sawtooth waveforms are then amplified by the Upper and Lower Beam horizontal amplifiers and applied to their respective horizontal-deflection plates of the cathode-ray tube.

When external sweep waveforms are used, waveforms are connected through the EXT. HORIZ. INPUT connectors to the appropriate external horizontal amplifiers. The output signals from the external amplifiers are amplified by the horizontal amplifiers and applied to the horizontal-deflection plates to produce the desired deflection.

The sawtooth waveform from the Time Base A generator is applied to the delay pickoff circuit. This circuit utilizes the

sawtooth waveform to generate an output pulse after an adjustable delay time. This delayed triggering pulse is applied to the DELAYED TRIG. OUT connector and to Time Base B. The delayed trigger pulse can be used to initiate a delayed sweep by Time Base B.

The amplitude calibrator produces a square wave output waveform which can be used to check the calibration of the vertical deflection system. The calibration voltage is also used to compensate probes.

There are six regulated low-voltage power supplies in the Type 555 Oscilloscope. These power supplies provide the operating voltages for all circuits except the cathode-ray tube. Operating voltages for the crt are provided by separate high-voltage power supplies contained in the crt circuit. In addition to the high-voltage power supplies, the crt circuit contains all the controls and circuitry which affect the crt display.

### Vertical Deflection System

Since both Upper and Lower Beam vertical deflection systems are identical, the description that follows applies to both systems. The Upper Beam vertical deflection system block diagram is shown in Figure 4-2.

Input signals to the oscilloscope are applied to the input connector of the vertical plug-in unit used with the oscilloscope. The plug-in unit provides a balanced push-pull output to the oscilloscope vertical amplifier through the interconnecting plug.

The Type 555 vertical amplifier consists of three dc-coupled push-pull stages providing sufficient amplification to drive the vertical-deflection plates of the crt. The frequency response of the vertical amplifier is extended to dc to 30 mc through the use of low and high frequency compensation and a distributed amplifier output stage. The distributed amplifier consists of six push-pull sections, the separate gains of which are additive. Together these sections provide sufficient gain at high frequencies to bring the upper 3-db-down point to 30 mc.

The push-pull output of the vertical amplifier is applied through a balanced delay line to the vertical-deflection plates of the crt. The delay line delays the application of the vertical signal to the deflection plates until the crt has been unblanked and the horizontal sweep started. This delay allows the leading edge of the fast rising pulses to

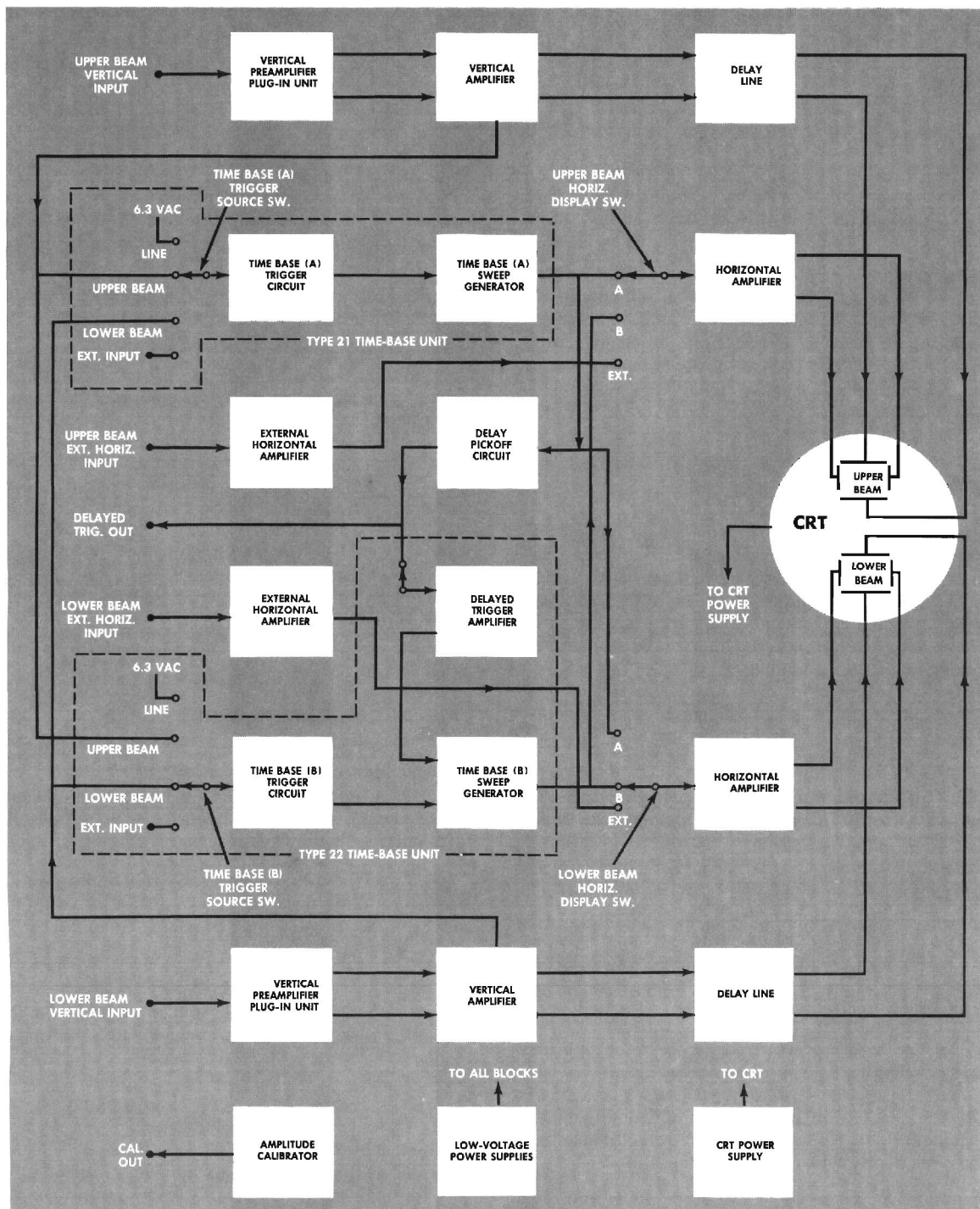

Fig. 4-1. Block Diagram of the Type 555 Oscilloscope.

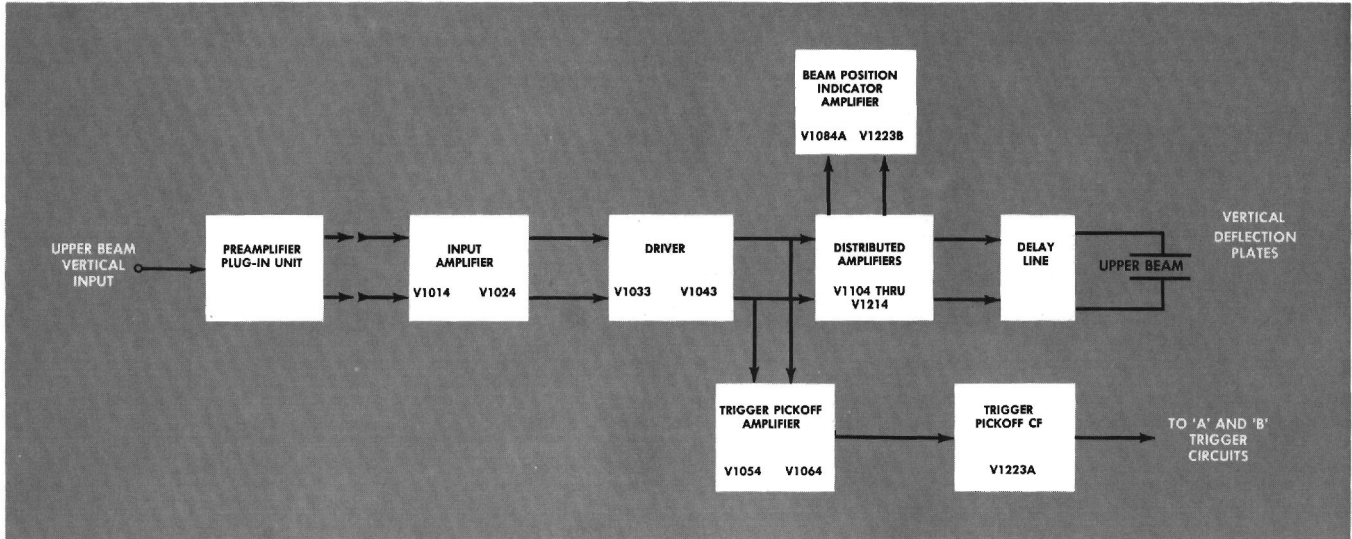

Fig. 4-2. Upper Beam Vertical-deflection system block diagram.

be displayed. The delay line is adjusted by means of variable capacitors for minimum waveform distortion.

A push-pull output from the vertical amplifier is also applied to the trigger pickoff circuit. This circuit consists of an amplifier stage and a cathode follower. The amplifier stage receives the push-pull input signal and provides a single-ended output signal which is in phase with the signal originally applied to the input of the plug-in unit. The output of the amplifier stage is applied through the trigger pick-off cathode follower to the triggering circuits of either or both time base units.

### Triggering Circuit

The triggering circuits in both time base units are identical. Therefore, only one circuit is described and one block diagram, Figure 4-3, is shown.

The triggering signals from the line, external input, Upper Beam amplifier, and Lower Beam amplifier are connected to the input of the triggering circuit. The signal selected by the trigger SOURCE switch is then connected to one of the grids of the trigger-input amplifier through the COUPLING and SLOPE switches.

The trigger-input amplifier is a difference amplifier stage which compares the amplitude of the triggering signal on one grid to the voltage on the other grid obtained from the TRIGGER LEVEL control. The output of the trigger amplifier is applied to the trigger multivibrator, a Schmitt Trigger Circuit. When the output of the amplifier reaches a certain level the trigger multivibrator switches to produce a trigger pulse which is applied to the sweep circuit. The trigger multivibrator then resets to await the next triggering waveform.

When the trigger circuit is set for AC AUTO. operation, a feedback circuit is provided for the trigger multivibrator which causes the multivibrator to free run at approximately a 50-cycle rate. When a triggering signal is applied, the trigger multivibrator is synchronized by the triggering waveform, and the circuit operates as described in the previous paragraph.

### Time Base Generator

The block diagram, Figure 4-4, shows the areas where differences occur between the type 21 and the Type 22 Time Base Units. In the following description the differences are noted in the text and on the block diagram.

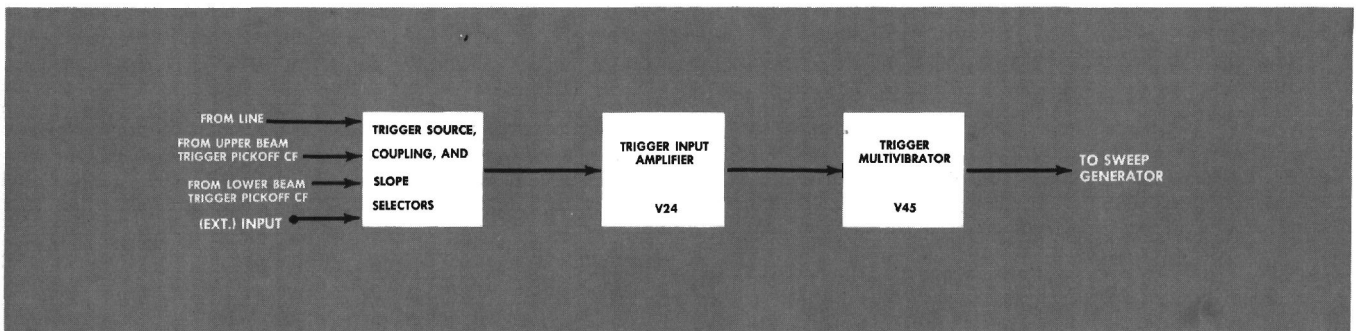

Fig. 4-3. Trigger-Circuit block diagram.

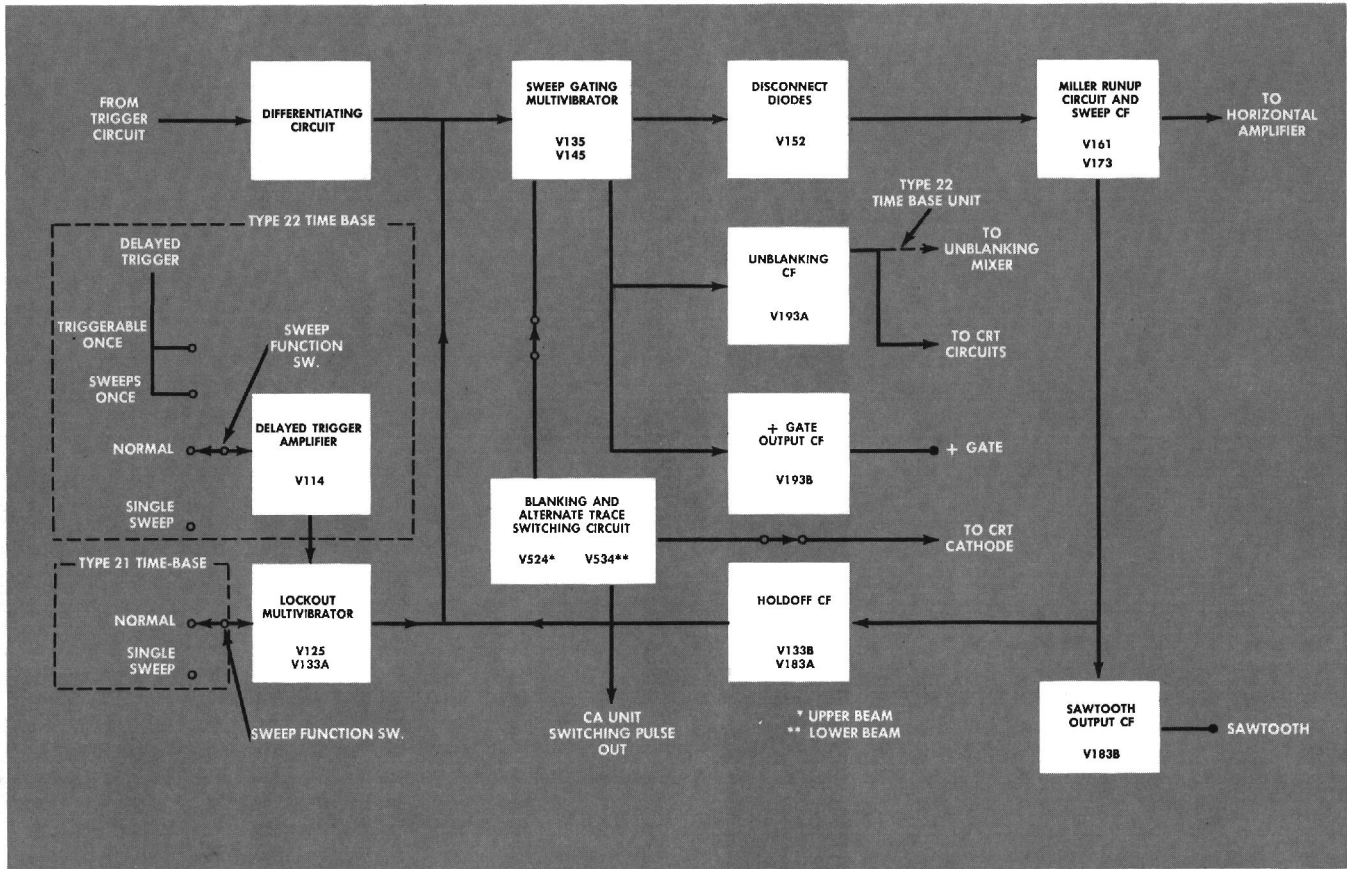

Fig. 4-4. Time Base Generator block diagram for the Type 21 and 22 Time Base Units. Differences between the two are marked.

The output pulse from the trigger multivibrator is applied to the sweep gating multivibrator through a differentiating network. The sweep gating multivibrator is a Schmitt Trigger Circuit which acts as an electronic switch for the sweep circuit. When the triggering pulse is applied, the sweep gating multivibrator switches, thereby cutting off the disconnect diodes and allowing the Miller Run-Up Circuit to operate. One output of the sweep gating multivibrator is connected through the unblanking cathode follower to the crt to unblank the tube. Another output is connected through the +gate output cathode follower to the +GATE connector on the front panel.

Synchronizing pulses are supplied by the sweep gating multivibrator to operate the blanking and alternate trace switching circuits. The switching circuits are used in the ALTERNATE mode of the TYPE CA Plug-In Unit with either one or both time bases.

The disconnect diodes clamp the sweep-circuit output voltage at a fixed level between sweeps. This prevents horizontal jitter at the start of the sweep. When the disconnect diodes are cut off, their clamping action stops and the Miller Run-Up Circuit operates.

The Miller Run-Up Circuit is a modified Miller Integrator circuit which provides an extremely linear output sawtooth waveform. The sawtooth waveform is built up on a timing capacitor which is an integral part of the circuit. The rate

that the charge builds up on the timing capacitor determines the sweep time per centimeter. The rate of charge is in turn dependent on the time constant of the timing capacitor and timing resistor. The sweep timing is set with the TIME/CM control by varying this time constant. All sweep ranges are accurately calibrated by means of variable timing capacitors and resistors.

The output sawtooth from the Miller Run-Up Circuit is applied through the sweep cathode follower to the horizontal amplifier. Feedback from the sweep cathode follower is applied to the timing capacitor to eliminate nonlinearity in the charging of the capacitor. This feedback insures a linear sawtooth waveform. The sawtooth waveform from the sweep cathode follower is also connected through the sawtooth output cathode follower to the SAWTOOTH connector on the front panel.

The sawtooth waveform from the sweep cathode follower is applied through the holdoff cathode followers to reset the sweep gating multivibrator at the end of each sweep. The holdoff cathode followers then insure that the sweep gating multivibrator is not switched again until the Miller Run-Up Circuit has reset and become stabilized.

The dc level at the input of the sweep gating multivibrator is controlled by the lockout multivibrator, STABILITY control, the RECURRENT position of the trigger LEVEL control, and the SWEEPS ONCE position (Type 22 only) of the

SWEEP FUNCTION switch. In normal sweep operation, one half of the lockout multivibrator is disabled while the other half operates as cathode follower. The voltage at the input of the sweep gating multivibrator is then controlled through the cathode follower by the STABILITY control, the RECURRENT position of the trigger LEVEL control, and the SWEEPS ONCE position (Type 22) of the SWEEP FUNCTION switch. The STABILITY control is set to allow normal triggering of the sweep gating multivibrator without causing it to free-run. However, should a free-running sweep be desired, the trigger LEVEL control can be turned full right to the RECURRENT position. This action closes a switch, lowers the dc level at the input of the sweep gating multivibrator, and permits the next sweep to begin after the hold-off period. The same action occurs when the SWEEPS ONCE position (Type 22) is used for delayed sweep operation.

When the time base generator is used for either a SINGLE SWEEP or delayed-sweep TRIGGERS ONCE (Type 22) presentation, both sections of the lockout multivibrator operate and the multivibrator acts as an electronic switch to control operation of the sweep gating multivibrator. One condition of the lockout multivibrator disables the sweep gating multivibrator to prevent any horizontal sweeps. This condition exists until a delayed trigger is applied to the lockout multivibrator (Type 22) or until the PUSH TO RESET switch is depressed. When the lockout multivibrator switches, operation of the sweep gating multivibrator returns to normal to allow one horizontal sweep. Depending on the setting of the trigger LEVEL control, this sweep may occur immediately or be delayed until a triggering pulse is applied from the triggering circuit or from the delayed trigger amplifier (Type 22) to the sweep gating multivibrator.

When the sweep occurs, an output from the holdoff cathode follower is applied to reset the lockout multivibrator. The sweep gating multivibrator is again disabled by the lockout multivibrator until the next delayed trigger (Type 22) occurs or until the PUSH TO RESET button is again depressed.

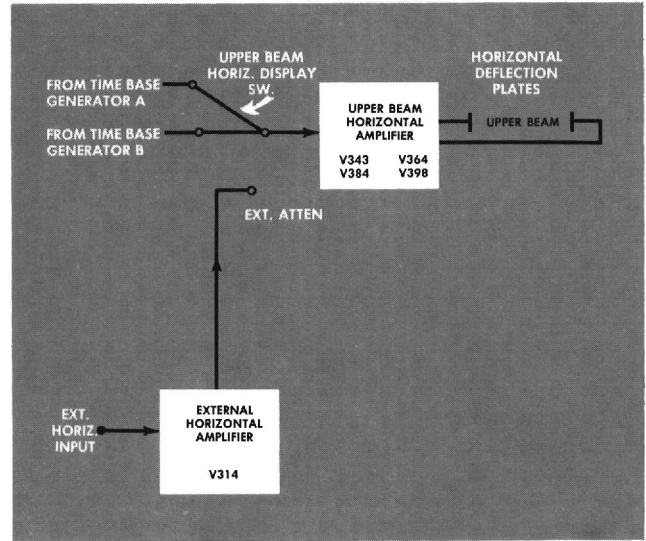

Fig. 4-5. Upper Beam Horizontal-deflection system block diagram.

### Horizontal Amplifier

The Upper and Lower Beam horizontal amplifiers are identical. Although the block diagram, Figure 4-5, illustrates the Upper Beam horizontal-deflection system, the description applies to both.

The input to the horizontal amplifier is selected from waveforms applied from Time Base Generator A, Time Base Generator B, and the external horizontal amplifier. The

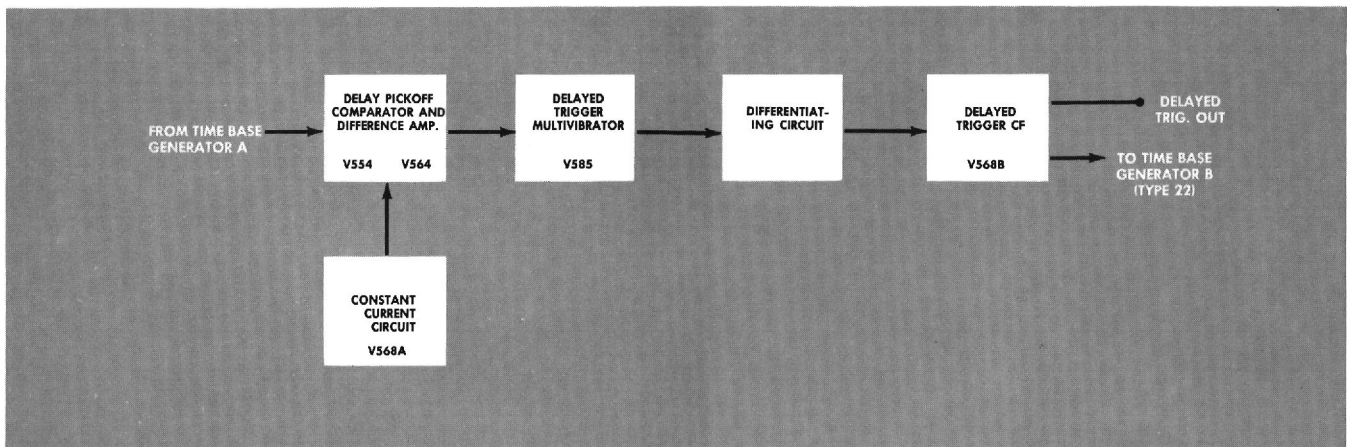

Fig. 4-6. Delay Pickoff Circuit block diagram.

## Theory of Operation — Type 555

selected input waveform is split in phase and amplified to drive the horizontal-deflection plates of the crt. The amplifier is designed for optimum operation with a sawtooth input waveform.

A feedback network from the output of the amplifier to the first amplifier stage is used to reduce the gain of the amplifier to the amount necessary for a normal-sweep presentation. The gain of the amplifier is controlled by adjustment of the feedback network. When the sweep magnifier is used, a portion of the degenerative feedback network is shorted out to increase the gain of the amplifier by a factor of 5. This provides the magnified-sweep presentation.

The external horizontal amplifier is a cathode coupled circuit which provides the necessary gain to drive the horizontal amplifier from external signals. An input attenuator and a gain control provide horizontal deflection factors between approximately 0.2 and 20 volts per centimeter.

### Delay Pickoff Circuit

A sawtooth waveform from Time Base Generator A is applied to the input of the delay-pickoff comparator circuit. This circuit is a difference amplifier which compares the voltage level of the input sawtooth against a fixed voltage obtained from the DELAYED TRIGGER control. When the voltage level of the input sawtooth waveform reaches a certain level,

as determined by the setting of the DELAYED TRIGGER control, the output of the comparator circuit triggers the delayed-trigger multivibrator. The delayed trigger multivibrator then initiates the delayed trigger which is applied through a differentiating circuit to the delayed-trigger cathode follower. Outputs from the delayed-trigger cathode follower are then applied to the DELAYED TRIG. OUT connector on the front panel and to the 'B' sweep circuit.

### CRT Circuit

Cathode-ray tube operating voltages are obtained from two separate high-voltage power supply circuits. The circuits are the same for both supplies except that the post-accelerating voltage is supplied by the lower beam circuit. The outputs from the oscillator circuits are taken from the secondary windings of the high voltage transformers.

The primary winding of the high-voltage transformer forms a part of the oscillator circuit. The transformer steps up the oscillator output voltage to the required level. The voltage is then rectified, filtered, and applied to the appropriate crt beam circuits. Control-grid and cathode operating voltages are obtained from conventional rectifier circuits. A voltage-doubler circuit supplies the post-accelerating voltage.

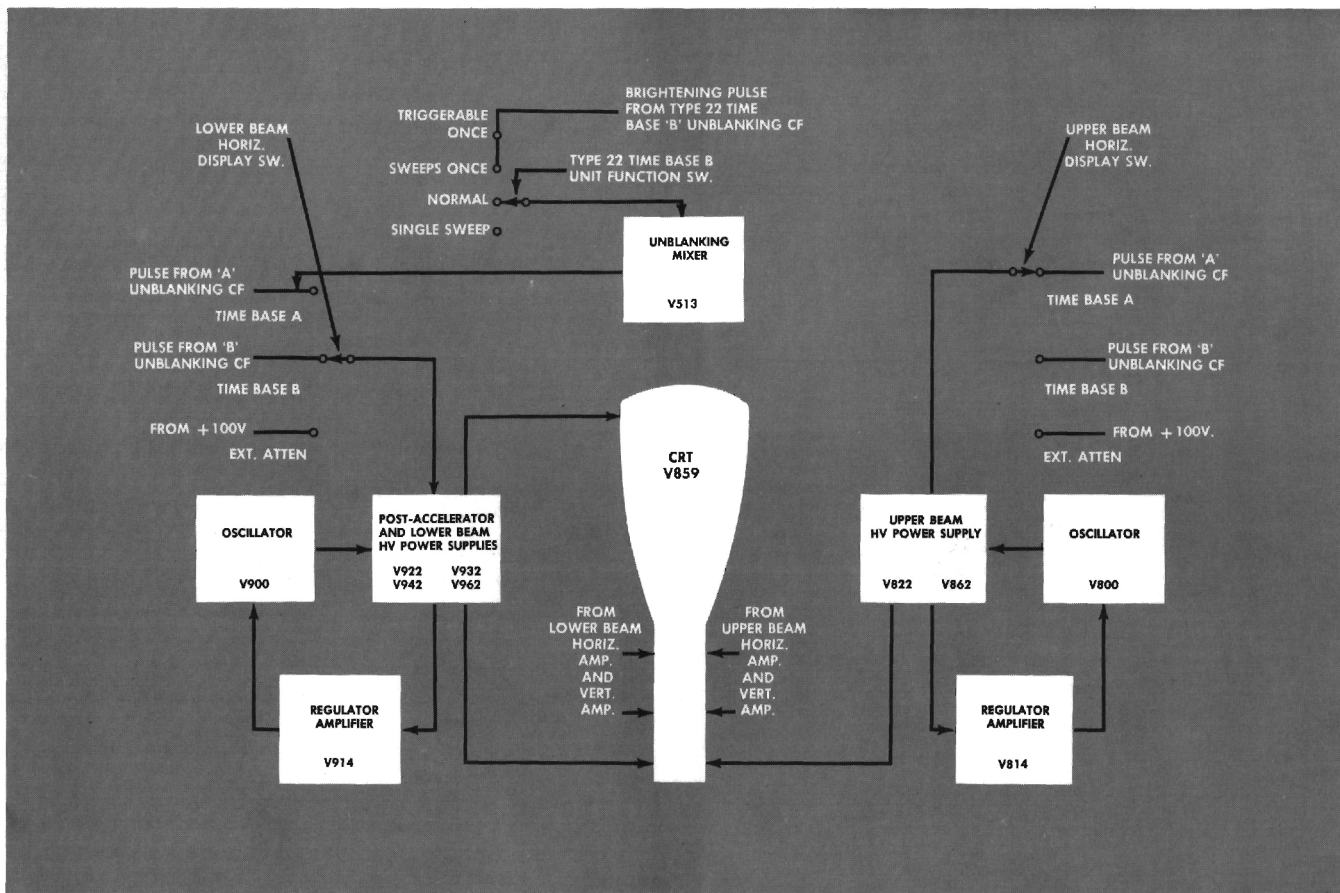

Fig. 4-7. CRT Circuit block diagram.

A sample of the power-supply voltage is fed back through the regulator amplifier to the high-voltage oscillator. This voltage controls the amplitude of the oscillator output and compensates for any changes in the output voltages of the high-voltage power supply.

Additional crt circuits control intensity, geometry, astigmatism, and focus for each beam of the crt display. Unblanking pulses from the two sweep circuits are applied to the appropriate crt control grid through the Upper and Lower Beam HORIZ. DISPLAY switches to unblank the trace during sweep time. In addition, a brightening pulse from the Type 22 Time Base 'B' Unit is applied through the TRIGGERABLE ONCE and the SWEEPS ONCE positions of the FUNCTION switch. The brightening pulse is coupled through the unblanking mixer tube, either or both HORIZ. DISPLAY switches, and to either or both crt control grids. A portion of either or both beams is intensified to indicate the delayed sweep duration. In the absence of an unblanking pulse, the blanked tube eliminates any visible sweep retrace.

### Low-Voltage Power Supplies

The low-voltage power supplies produce all operating voltages for the oscilloscope with the exception of parts of the crt circuit. These power supplies produce regulated voltages of  $-150$ ,  $+100$ ,  $+225$ ,  $+350$ , and  $500$  volts, and, an unregulated output of  $330$  volts. In addition, a separate circuit regulates the  $6.3$  volt filament power.

Each of the dc power supplies operates in a similar manner. A sensing circuit compares a sample of the output voltage against a fixed reference voltage. Any error in the output voltage then produces an error signal which is

amplified and applied to the series regulator tubes, causing the series regulators to compensate for the error and return the output voltage to normal.

Reference voltage for the  $-150$ -volt supply is obtained from a gas-filled voltage-regulator tube. Reference voltages for the other dc regulated power supplies are obtained from the output of the  $-150$ -volt supply. Consequently, operation of all the dc regulated power supplies is dependent on the operation of the  $-150$ -volt supply. The output voltages of all the dc regulated power supplies are adjusted by adjusting the output of the  $-150$ -volt supply.

The regulated filament supply operates by regulating the voltage applied to the primary winding of the filament transformer. Errors in the filament voltage are sensed by the filament of a special diode. When an incorrect voltage is sensed, the diode conducts either more or less current depending on the direction of the error. The output from the diode is amplified by an additional stage. The amplifier controls the current through one winding of a saturable reactor. This in turn determines the amount of reactance presented by the reactor to the line voltage. The change in reactance compensates for any changes in the filament voltage.

### Calibrator

The calibrator multivibrator, free running at approximately a  $1000$ -cycle rate, produces the amplitude-calibrator square waves. The square waves are applied through the calibrator output cathode follower and a precision attenuator to the CAL. OUT connector on the front panel. Accuracy of the calibrator output is insured by adjusting the multivibrator output voltage.

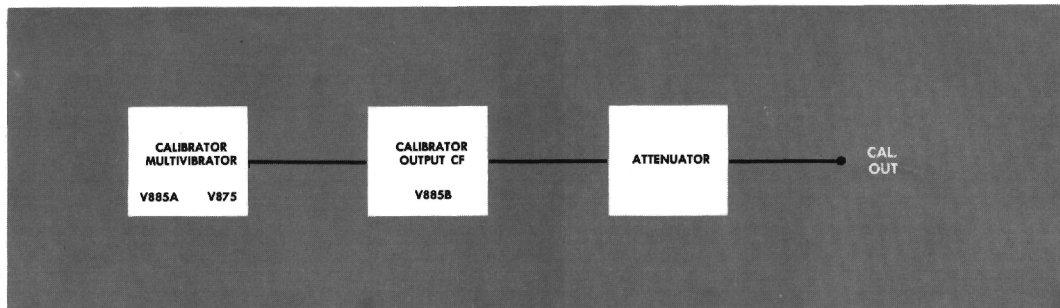
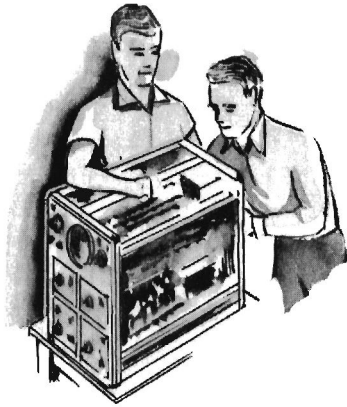

Fig. 4-8. Amplitude Calibrator block diagram.

# SECTION 5

# MAINTENANCE



## PREVENTIVE MAINTENANCE

### Air Filter

The Type 555 Oscilloscope is cooled by air drawn into both units through washable filters constructed of adhesive-coated aluminum wool. If the filters become dirty, they will restrict the flow of air and may cause the instrument to overheat. You should inspect and clean the filters every three or four months. Any time that the thermal relay in either unit opens up, the filters should be checked immediately.

To clean the filter, first remove loose dirt from the filter by rapping it gently on a hard surface. Then wash the filter briskly with hot soapy water. After rinsing and drying thoroughly, coat the filter with "Handi-Koter" or "Filter-coat", products of the Research Products Corporation. These products are generally available from air-conditioner suppliers.

### Fan Motor

The indicator unit fan motor bearings should be lubricated every three or four months with a few drops of light machine

oil (see Figure 5-1). Failure to lubricate the bearings periodically will cause the fan to slow down or stop thereby causing instrument overheating. The power supply unit fan motor bearings are factory sealed and no lubrication is required.

### Visual Inspection

You should visually inspect the entire indicator and power supply units every few months for possible circuit defects. These defects may include such things as loose or broken connections, damaged binding posts, improperly seated tubes, scorched wires or resistors, missing tube shields, or broken terminal strips. For most visual troubles the remedy is apparent; however, particular care must be taken when heat-damaged components are detected. Overheating of parts is often the result of other, less apparent, defects in the circuit. It is essential that you determine the cause of overheating before replacing heat-damaged parts in order to prevent further damage.

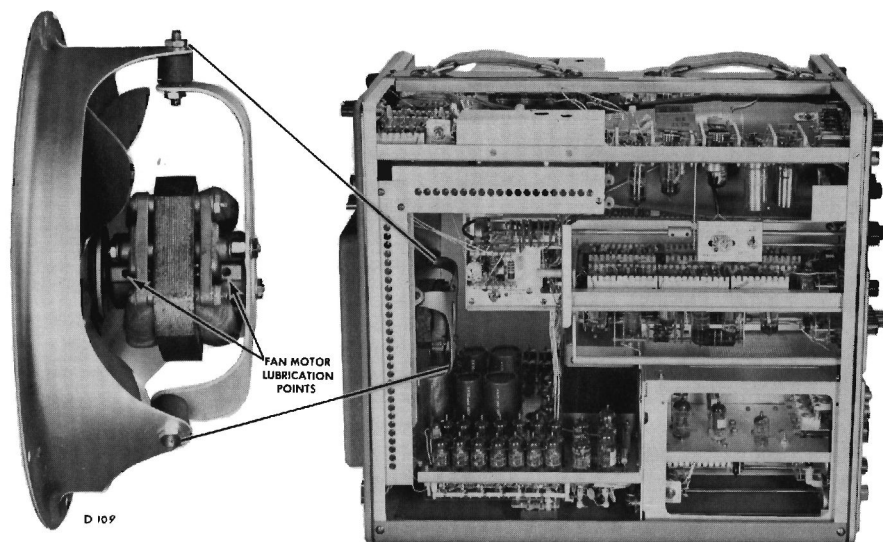

Fig. 5-1. Location of the indicator unit fan-motor lubrication points.

## Recalibration

The Type 555 Oscilloscope is a stable instrument that will provide many hours of trouble-free operation. However, to insure the reliability of measurements we suggest that you

recalibrate the instrument after each 500 hours of operation (or every six months if used intermittently). A partial calibration procedure is given in the Internal Adjustments portion of this manual. Complete recalibration procedures are given in Section 7.

## REMOVAL AND REPLACEMENT OF PARTS

### General Information

Procedures required for replacement of most parts in the Type 555 Oscilloscope are obvious. Detailed instructions for their removal are therefore not required. Other parts, however, can best be removed if a definite procedure is followed. Instructions for the removal of some of these parts are contained in the following paragraphs. Because of the nature of the instrument, replacement of certain parts will require that you recalibrate portions of the oscilloscope to insure proper operation. Refer to the Recalibration Procedure or to the Internal Adjustments portion of this manual for calibration procedures.

### Removal of Panels

The panels of the Type 555 Oscilloscope are held in place by small screwhead fasteners. To remove the side panels, use a screwdriver to rotate the fasteners approximately two turns counterclockwise; then pull the upper portion of the panels outward from the carrying handles. To remove the bottom panel, lay the instrument on its side, rotate the fasteners approximately two turns counterclockwise, and pull off the panel. Panels are replaced by reversing the order of their removal.

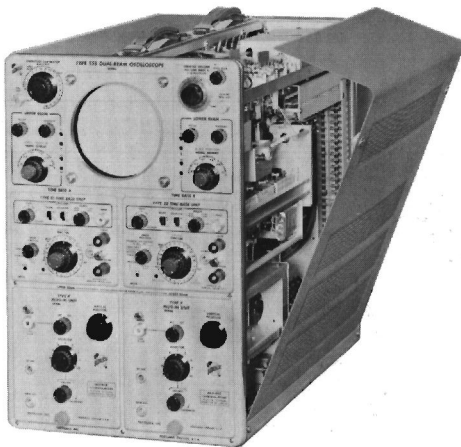

Fig. 5-2. Removal of the indicator unit side panels.

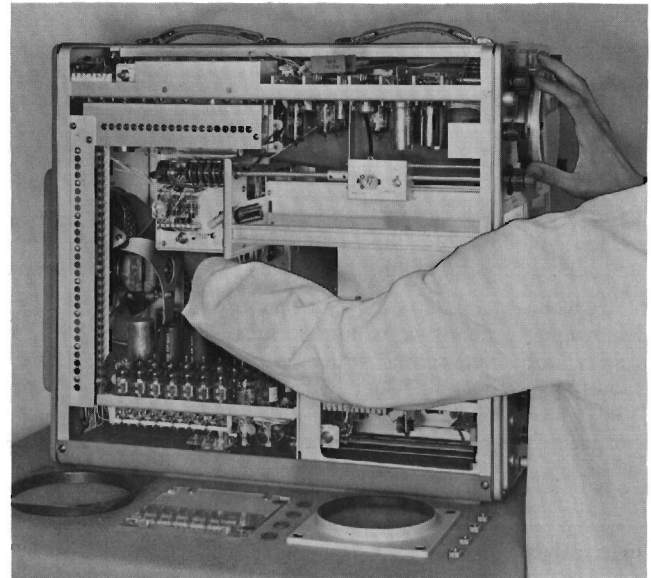

Fig. 5-3. Removing the cathode-ray tube.

### Replacement of the Cathode-Ray Tube

To remove the cathode-ray tube, first, remove the time base units and disconnect all clip leads connected to the neck of the tube. Leave the beam rotation coil leads and the high-voltage nipple connected. Remove the graticule cover, spacer washers, graticule, and graticule light shield. Disconnect the crt from the socket at the base of the crt. If you have trouble separating the crt from the socket, the crt can be worked loose easily by carefully wedging a plastic tool between the socket and the base of the crt. By first loosening one side and then the other, the crt can be worked free of the socket. Remove the crt by pushing it forward through the front panel far enough to be removed from the front of the oscilloscope (see Figure 5-3).

When the new crt is in place, the leads can be properly connected to the neck of the tube by following the color code information provided on the tube shield. After replacement of the crt, it will be necessary to check the calibration of the oscilloscope.

### Replacement of Switches

Methods for removal of defective switches are, for the most part, obvious and only a normal amount of care is

required. Single wafers are normally not replaced on the switches used in the Type 555. If one wafer is defective, the entire switch should be replaced. Switches can be ordered from Tektronix either wired or unwired as desired.

## Tube Replacement

Care should be taken both in preventive and corrective maintenance that tubes are not replaced unless they are actually causing a trouble. Many times during routine maintenance it will be necessary for you to remove tubes from their sockets. It is important that these tubes be returned to the same sockets unless they are actually defective. Unnecessary replacement or switching of tubes will many times necessitate recalibration of the instrument. If tubes do require replacement, it is recommended that they be replaced by previously checked high-quality tubes.

## Soldering Precautions

In the production of Tektronix instruments, a special silver-bearing solder is used to establish a bond to the ceramic terminal strips. This bond can be broken by repeated use of ordinary tin-lead solder, or by the application of too much heat. However, occasional use of ordinary solder will not break the bond if too much heat is not applied.

It is advisable that you have a stock of solder containing about 3% silver if you frequently perform work on Tektronix instruments. This type of solder is used frequently in printed circuitry and should be readily available. It may also be purchased directly from Tektronix in one-pound rolls (order by part number 251-514).

Because of the shape of the terminals on the ceramic terminal strips, it is advisable to use a wedge-shaped tip on your soldering iron when you are installing or removing parts from the strips. A wedge-shaped tip allows you to apply heat directly to the solder in the terminals and reduce the amount of heat required. It is important to use as little heat as possible.

## REPLACEMENT PARTS

### Standard Parts

Replacement for all parts used in the Type 555 Oscilloscope can be purchased directly from Tektronix at current net prices. However, since most of the components are standard electronic parts, they can generally be obtained locally in less time than is required to obtain them from the factory. Before ordering or purchasing parts, be sure to consult the parts list to determine the tolerances and ratings required. The parts list gives the values, tolerances, ratings, and Tektronix parts numbers for all components used in the instrument.

### Special Parts

In addition to the standard electronic components mentioned in the previous paragraph, special parts are also used in the assembly of the Type 555 Oscilloscope. These parts are manufactured or selected by Tektronix to satisfy particular requirements or are manufactured specially for Tektronix by other companies in accordance with Tektronix specifications. These parts and most mechanical parts should be ordered directly from Tektronix since they are normally difficult or impossible to obtain from other sources. All parts may be obtained either directly from the factory or through the local Tektronix Field Office.

### Parts Ordering Information

Each part in the Type 555 Oscilloscope has a 6-digit Tektronix part number. This number and a description of the part, will be found in the parts list. When ordering parts, be sure to include both the description of the part and the part number. For example, if the serial number of your Type 555 Oscilloscope is 4987, a certain resistor would be ordered as follows: R160A, 100 k, 1/2 watt, fixed precision, 1%, part number 309-045, for Type 555 Oscilloscope, Serial Number 4987. When parts are ordered in this manner, we are able to fill your orders promptly, and delays that might result from transposed numbers in the part number are avoided.

Since the production of your instrument, some of the parts may have been superseded by improved components. In such cases, the part numbers of these new components will not be listed in your Parts List. However, if you order a part from Tektronix and it has been superseded by an improved component, the new part will be shipped in place of the part ordered. Your local Tektronix Field Engineering Office has knowledge of these changes and may call you if a change in your purchase order is necessary.

Replacement information sometimes accompanies the improved components to aid in their installation.

## TROUBLESHOOTING

### Troubleshooting Information

This portion of the Operator's Manual provides brief troubleshooting information which can be used, when a trouble exists, to isolate the defective circuit or stage. No

attempt is made here to provide detailed information for troubleshooting within the circuits.

Before attempting any troubleshooting work, you should check all controls for proper settings. If you are in doubt about control settings you should review the Operating In-

formation section of this manual. When you have ascertained that a trouble does exist in the instrument, you can then proceed to isolate the defective circuit using the procedures contained later in this section.

Although the Type 555 Oscilloscope is a stable instrument, many apparent troubles will be due to improper calibration of one or more circuits. One of the first steps in any troubleshooting procedure should be to check the calibration of the suspected circuit. Calibration of this instrument can be easily checked by comparing the upper beam operation to the lower beam. Partial calibration procedures are given in the Internal Adjustments portion of this handbook; complete calibration procedures are given in the Recalibration Procedure section.

Power-supply output voltages should be checked whenever any type of trouble occurs in the instrument. Due to the circuit configuration employed in the Type 555, it is possible for an incorrect power-supply voltage to affect one circuit more than others. When all but one circuit in the oscilloscope is functioning properly, there is a tendency to overlook the power supply as a source of the trouble and to concentrate on the circuit where the trouble apparently exists. In cases of this type (valuable time can be saved by checking the power supplies first. If the output and ripple voltages of the regulated power supplies are correct, the power supplies can be assumed to be operating correctly.

When a trouble has been isolated to a definite circuit, perform a complete visual check of that circuit. Many troubles can be found most easily by visual means. If a visual check fails to detect the cause of the trouble, check all tubes by substitution. Tube failure is the most prevalent cause of circuit failure. Do not depend on tube testers to adequately indicate the suitability of a tube for use in the instrument. The criterion for usability of a tube is whether or not it works satisfactorily in the instrument. Be sure to return any tubes found to be good to their original socket.

Separate schematic diagrams for each circuit are contained in the Parts List and Schematic Diagrams Booklet used in conjunction with this manual. In addition, a block diagram provides an overall picture of instrument operation. The reference designation of each electronic component of the instrument is shown on the circuit diagrams.

Switch wafers shown on the schematic diagrams are coded to indicate the position of the wafer on the actual switches. The number portion of the code refers to the wafer number on the switch assembly, wafers being numbered from the front of the switch to the rear. The letters F and R indicate whether the front or the rear of the wafer is used to perform the particular switching function.

All wiring used in the Type 555 Oscilloscope is color coded to facilitate circuit tracing. In addition, primary power, filament, and power-supply output leads are distinguished by specific color codes. All power-supply output leads follow the standard RETMA code. For example, the -150-volt bus is coded brown-green-brown and the +500-volt bus is coded green-black-brown. The widest stripe identifies the first color of the code.

The troubleshooting procedures that follow are divided into sections according to trouble symptoms. When a trouble occurs in the instrument, the proper troubleshooting section can quickly be found by using the trouble symptoms.

### No Spot or Trace

No spot or trace on the crt screen is indicative of horizontal- or vertical-deflection system unbalance or of a failure of the crt circuits. When this trouble occurs, first check the beam position indicator lights for each beam and the setting of the INTENSITY controls. The lights will indicate whether the beam is deflected off the crt screen. If the beam is positioned off the screen, use the appropriate position controls and the beam-position indicators to attempt to center the beam. If the beam centers properly, as indicated by the beam-position indicators, but no spot or trace appears with normal INTENSITY control setting for that beam, the trouble is probably in one of the crt circuits. Additional checks should be made, however, before you start working on the circuits. The following checks can quickly be made to show conclusively whether or not the trouble exists in one of the crt supply circuits.

Center both beams using the indicator lights and turn up the INTENSITY controls to a setting a little higher than used normally. Be prepared to turn the appropriate INTENSITY control down to normal brilliance if the beam spot or trace suddenly appears. If the lower beam trace can be seen, but not the upper beam, then look for the upper gun's filament glow at the base of the crt. If the filament is operating, check for deflection unbalance even though the indicator lights show the beam to be centered. To do this, place a jumper between the upper beam horizontal- or vertical-deflection plates of the crt at the neck of the tube.

If the upper beam trace does appear when one set of plates are shorted together, an unbalance exists in the deflection system which is connected to those plates. The jumper can be used to move back through the push-pull amplifier stages to make point checks to isolate the area of original unbalance.

Horizontal unbalance is generally caused by an unbalanced horizontal amplifier. Vertical unbalance, however can be produced in either the plug-in unit or the vertical amplifier of the oscilloscope. Perhaps the easiest way to determine whether the plug-in unit or the oscilloscope is at fault is to check the operation of the instrument by exchanging plug-ins. Turn the instrument off, remove the two vertical plug-ins, re-insert them in the opposite compartments, and turn the instrument on. If the plug-in is not at fault, be sure to check the leads which go to the crt deflection plates are properly connected at the neck of the crt before checking for other causes of vertical unbalance.

If no upper beam unbalance condition exists and the spot is not yet visible, then the upper beam crt circuit is at fault. Conversely, the same checks can be made to isolate lower beam troubles. However, if both filaments are oper-

Fig. 5-4. Left side view of the indicator unit

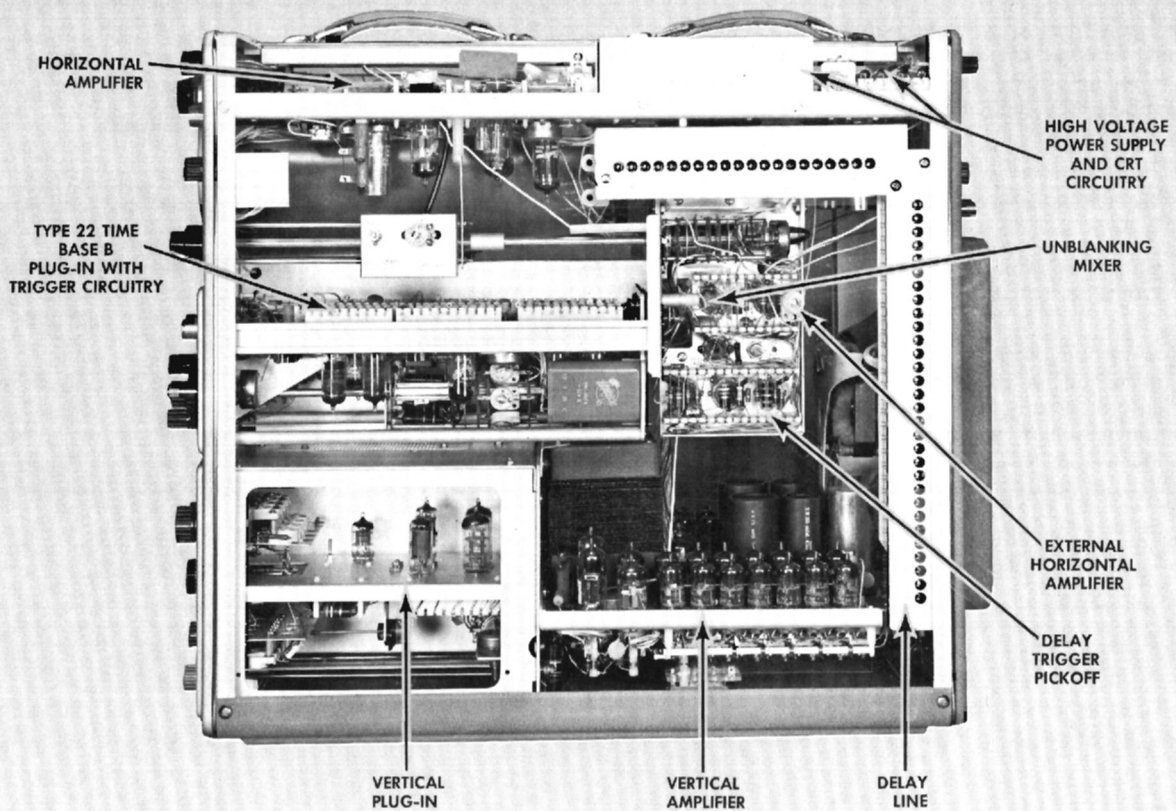
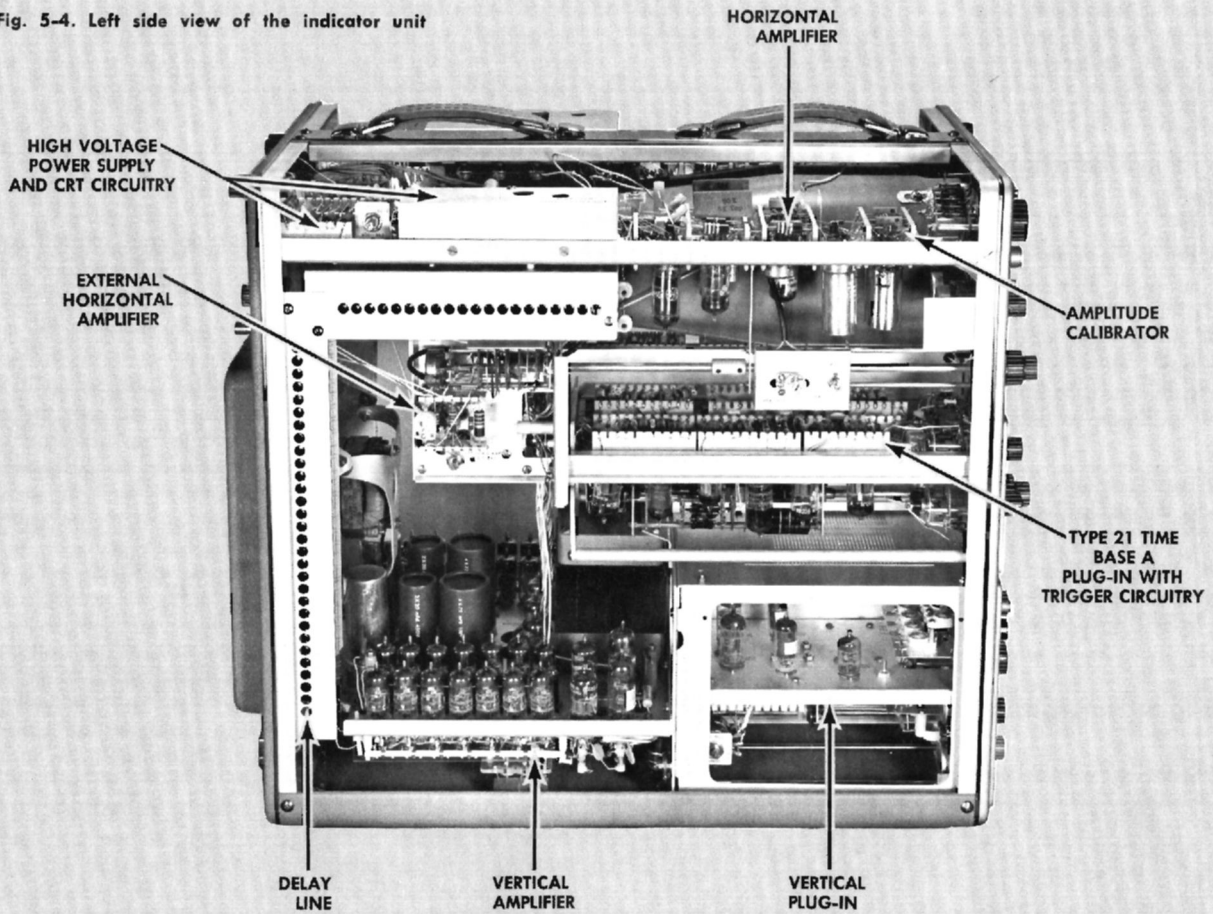

Fig. 5-5. Right side view of the indicator unit

ating and neither beam spot or trace appears, the trouble is probably in the lower beam crt circuit which supplies the common post-accelerating potential for both beams.

### **Waveform Distortion or Insufficient Vertical Deflection**

Both of these symptoms can be caused by troubles occurring in either the plug-in unit or the vertical-deflection system of the oscilloscope. The trouble can be isolated to one unit or the other easily by checking the operation of the oscilloscope after exchanging vertical plug-in units from one side to the other and by comparing the operation of the lower beam vertical-deflection system to the upper beam.

Small errors in gain and slight waveform distortion can often be corrected by calibrating either or both vertical-deflection systems of the oscilloscope and the plug-in units. An improperly compensated probe is also a common source of waveform distortion. Waveform distortion occasionally results from various tube conditions.

### **Insufficient Horizontal Deflection**

The Type 555 Oscilloscope contains two separate time-base units which can be used to isolate troubles in either horizontal-deflection system. When a trouble occurs, determine whether the trouble is present when you are using Time Base A, Time Base B, or an external horizontal input. When the trouble is present under all three conditions, the horizontal amplifier is at fault.

Troubles which occur only when you are using an external horizontal input voltage are probably due to a failure of the external amplifier being used. Try using the external horizontal amplifier for the other beam to compare differences between the two.

If the trouble occurs only when a particular time base is used, the trouble is in that time base unit.

### **Nonlinear Horizontal Sweep**

The linearity of the horizontal-deflection system can be checked by connecting the calibrator waveform to the vertical input of the oscilloscope. If the sweep is linear, the calibrator waveforms should be spaced equally along the sweep. A nonlinear sweep can be caused by one of the time-base units or horizontal amplifiers. If the trouble

exists when either time-base unit is used with one of the horizontal amplifiers, then the horizontal amplifier is at fault. If the trouble is present only when a particular time-base unit is used, that time base unit is at fault.

### **Poor Triggering**

Troubles which affect triggering can be isolated by comparing the operation of the 'A' and 'B' trigger circuits. If, when using the same triggering source, only one triggering circuit operates abnormally, you can assume that the circuit is defective.

If neither trigger circuit operates properly when you trigger internally from the same beam source, the trigger pickoff circuit of that vertical amplifier is probably at fault. As is the case with other circuits, proper operation can often be restored by recalibration.

### **Change in Deflection Sensitivity**

A change in the deflection sensitivity of the instrument is indicated if the deflection, both vertical and horizontal for both beams, is either greater or less than the value indicated by the front-panel settings. This can be caused by a change in the gain of both the vertical and the horizontal amplifiers due to improper output voltages from the low-voltage power supplies. Or, it can be caused by a change in the crt sensitivity due to improper output voltages from the high-voltage power supply. If either the low or high-voltage power supplies require adjustment, these adjustments must be made in accordance with the procedures given in the Internal Adjustments or the Recalibration Procedure portion of this manual.

### **No Delayed Trigger or Delayed Sweep**

When no delayed trigger is present at the DELAYED TRIG. OUT connector, the delay pickoff circuit has probably failed. However before attempting to repair the delay pickoff circuit, be sure that the 'A' and 'B' sweep circuits are operating correctly. This can be done by obtaining a normal-sweep presentation using first one, and then the other, time-base unit.

If the delayed trigger appears normal but no delayed sweep can be obtained, the trouble is in the Type 22 Time Base Unit sweep circuit. A trouble in the 'B' sweep circuit which prevents you from obtaining a delayed sweep presentation will probably also affect single-sweep operation.

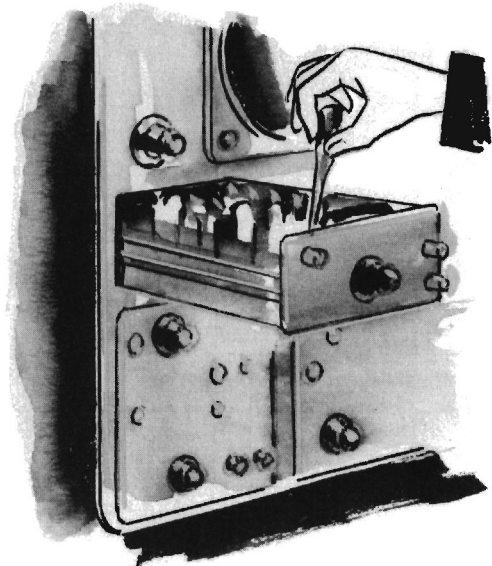

## SECTION 6

# INTERNAL ADJUSTMENTS

### Purpose

Procedures contained in this portion of the Operator's Manual permit you to calibrate certain portions of the Type 555 Oscilloscope. This section has purposely been simplified to include only the adjustments that can be made without special test equipment. It is assumed, however that an accurate dc voltmeter and an iron vane rms-reading ac voltmeter are available. The Type 555 is used as a test oscilloscope by using single-beam operation to make some of the adjustments.

Calibration procedures contained in this section cover controls which require adjustments most frequently. These procedures therefore provide sufficient information to correct most troubles which occur due to improper calibration. If it becomes necessary to calibrate the entire instrument, or to calibrate controls that are not covered here, you can refer to Section 7 where complete calibration procedures are given. All adjustments should be made with the plug-in units connected to the oscilloscope. The Time Base Plug-In Extension is used to make some of the time base adjustments.

If you find that it is impossible to adjust a particular control properly, there is a trouble in the instrument. This trouble must be located and corrected, before the adjustment can be made.

### CAUTION

The first two steps in the following procedure are used to adjust the output voltages of the low- and high-voltage power supplies. These adjustments are extremely important to proper operation of the instrument and must be made as accurately as possible. Care must be taken, however, that these adjustments are not made unnecessarily. The power supplies do not require adjustments unless there is more than a 3% error in their output voltages. Be sure that your voltmeters are accurate when checking the power supply voltages. An accurate iron vane rms-reading ac voltmeter must be used for reading the 6.3 VAC. A dc voltmeter with known corrected readings must be available to read the -150 and -1350 volts. If the power supplies have more than 3% allowable error, they must be adjusted as described in the Power-Supply Output Voltage and High Voltage steps.

If the controls in these first two steps are adjusted, the sweep timing and vertical deflection factors should be checked before measurements made with the instruments are assumed to be correct. Also, the other circuits should be checked for proper calibration.

### Power-Supply Output Voltage

Connect a dc voltmeter from the output of the -150-volt power supply (see Figure 6-1) to the chassis. Adjust the -150 ADJ. control for a voltage reading of exactly -150 volts.

Connect an iron vane ac voltmeter from the 6.3 VAC test point (see Figure 6-1) to the chassis. Adjust the REG. HTR. ADJ. for a voltage reading of 6.3 VAC.

### High Voltage

Connect the dc voltmeter from the lower beam high-voltage test point (see Figure 6-1) to the chassis. Adjust the lower beam H.V. ADJ. control for -1350 volts.

Connect the dc voltmeter from the upper beam test point (see Figure 6-1) to the chassis. Adjust the upper beam H.V. ADJ. control for -1350 volts.

### Amplitude Calibrator

Place the AMPLITUDE CALIBRATOR switch in the OFF position. Connect the dc voltmeter to the Calibrator Test Point (see Figure 6-10) and set the CAL. ADJ. control for a meter reading of exactly 100 volts.

### NOTE

The letter 'A' is used throughout this procedure as an abbreviation for "TIME BASE A" and the letter 'B' for "TIME BASE B". The 'A' triggering adjustments that follow must be made in the indicated sequence. Controls not mentioned in a particular step are assumed to be in the positions they were last in during the previous step.

### 'A' Trigger Level

Remove the Type 21 Time Base Unit, attach the Time Base Plug-In Extension to the Type 21 Unit, and install the unit with the extension in the TIME BASE A compartment of the Type 555.

Set the Upper Beam HORIZ. DISPLAY switch at 'A' X1. Place the 'A' SLOPE switch at +, 'A' COUPLING switch

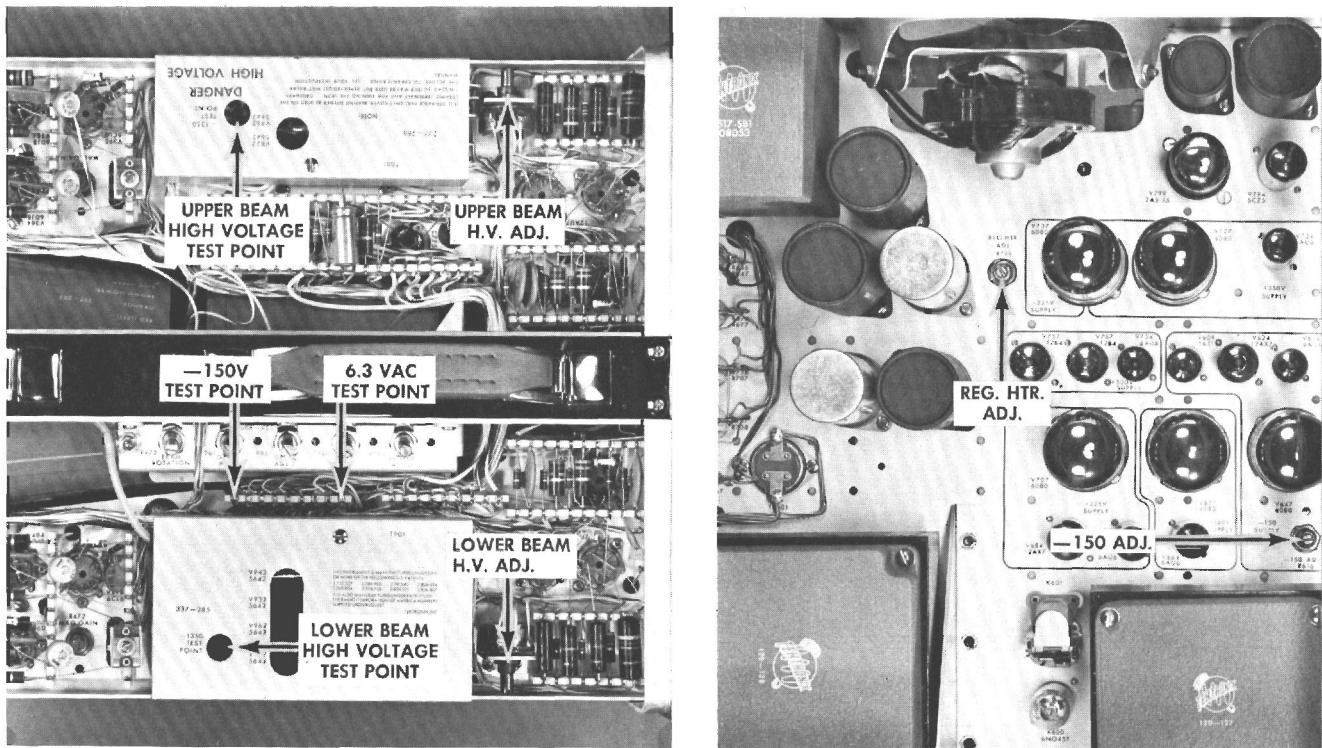

Fig. 6-1. Top view of indicator and power supply units showing location of low- and high-voltage adjustment controls and test points.

at DC, and 'A' SOURCE switch at UPPER BEAM. Rotate the 'A' LEVEL control to zero. Set the lower beam vertical plug-in VOLTS/CM switch at .05 and the input selector AC-DC switch at DC. Place the Lower Beam HORIZ. DISPLAY switch at 'B' X1. Set the 'B' trigger controls at AC AUTO., +SLOPE, AC COUPLING, and LINE SOURCE. Place the 'B' SWEEP FUNCTION switch at NORMAL and the 'B' TIME/CM switch at 2 MILLISEC. Center the lower beam trace at the lower horizontal centerline of the graticule and connect the 10X probe from the lower beam vertical input connector to the junction of R19 and R20 (see Figure 6-2). If the probe is being used with the clip lead ungrounded, position the probe body away from the 'A' SOURCE switch leads to prevent any feedback of signals. Rotate the 'A' LEVEL knob until the lower beam trace is again at the lower horizontal centerline. Loosen the 'A' LEVEL knob and set it at zero position. Retighten the knob and recheck it for exact zero setting and no vertical shift of the lower beam trace by disconnecting and connecting the probe a few times at the junction. Disconnect the probe from the junction.

#### 'A' Upper Beam Internal Trigger DC Level

Set the 'A' TIME/CM switch at .1 MILLISEC and rotate the STABILITY control clockwise for a free-running sweep. Position the upper beam trace to the upper horizontal centerline. Connect a short jumper from the junction of R19 and R20 to the chassis; connect a dc voltmeter from the junction of R22 and SW22 to the chassis (See Figure 6-2). Place the 'A' SLOPE switch in the — position and adjust the 'A' UPPER

BEAM INT. TRIG. D.C. LEVEL ADJ. control for a voltmeter reading of zero volts. Slide the SLOPE switch from — to + to check for accuracy of the adjustment and no voltmeter needle shift. Leave the SLOPE switch at —.

#### 'A' Lower Beam Internal Trigger DC Level

Position the lower beam trace to its centerline. Set the 'A' SOURCE switch at LOWER BEAM. Adjust the 'A' LOWER BEAM INT. TRIG. D.C. LEVEL ADJ. control for a voltmeter reading of zero volts and no change in meter needle movement when the 'A' SOURCE switch is set at UPPER BEAM and back to LOWER BEAM. Disconnect the voltmeter.

#### 'A' Trigger Level Centering

Rotate the lower beam vertical plug-in VOLTS/CM switch to the .5 volts position and set the input selector AC-DC switch at AC. Set the 'A' SOURCE switch at LINE. Connect the probe to pin 6 of V45 (see Figure 6-2). Preset the 'A' TRIG. LEVEL CENT. control so that the waveform on the lower beam is symmetrical. For precise adjustment set the Lower Beam HORIZ. DISPLAY switch at 'B' X.2 and horizontally center the + slope or switching portion of the multivibrator waveform using the 'B' HORIZ. POSITION control. Now slide the 'A' SLOPE switch up and down from — to + and, at the same time, readjust the 'A' TRIG. LEVEL CENT. for no horizontal shifting of the switching portion of the waveform. Leave the 'A' SLOPE switch at +.

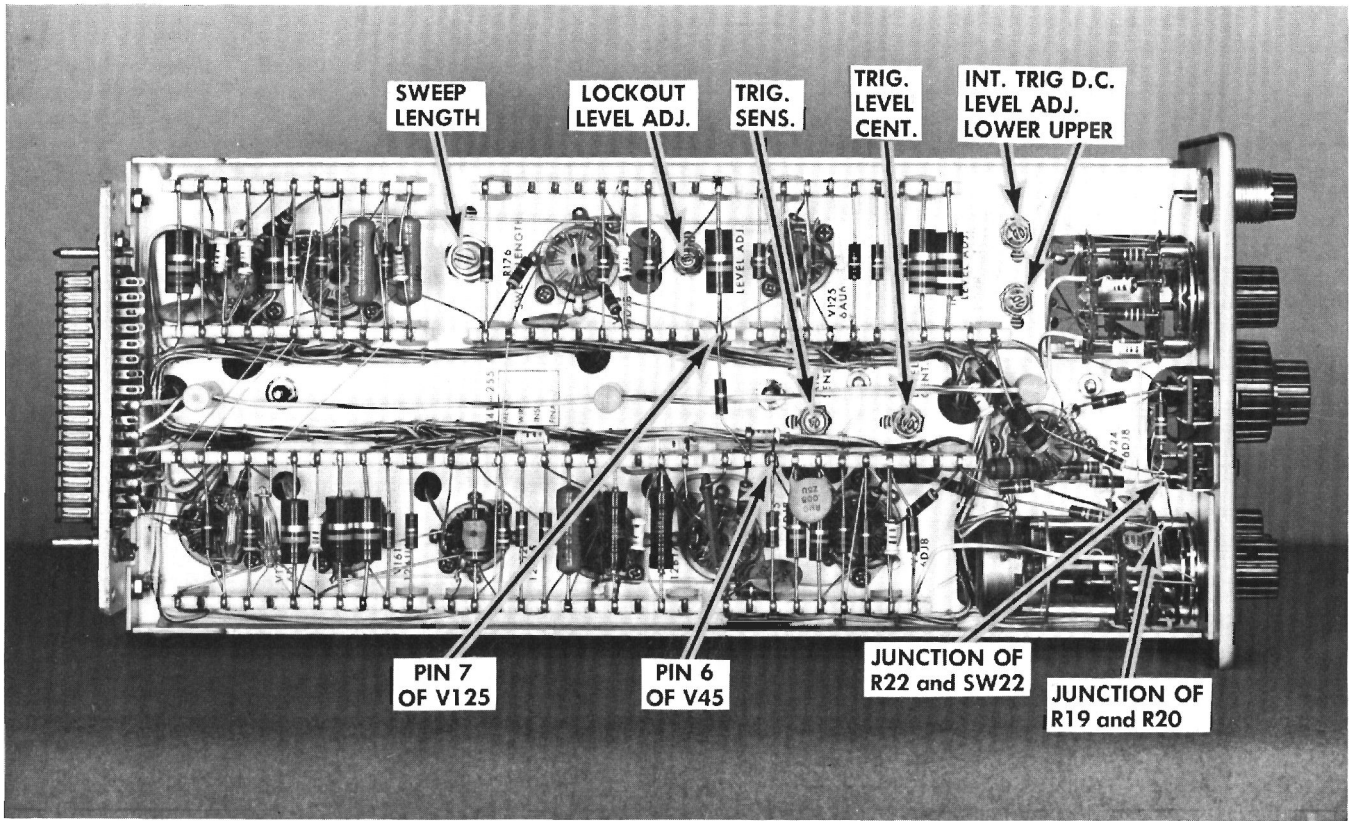

Fig. 6-2. Location of the Type 21 Time-Base Unit calibration controls and test points.

### 'A' Trigger Sensitivity

With the probe and jumper connected as described in the previous step, rotate the 'A' TRIG. SENS. control fully counterclockwise. Turn the control slowly clockwise and stop at the point where the oscillations cease to appear. Note the amplitude of the spike on the top corner of the multivibrator waveform. Then rotate the 'A' TRIG. SENS. control clockwise until this spike is slightly less than one half of the original size (see Figure 6-3). Disconnect the probe from the test point and remove the jumper lead.

### 'A' Lockout Level

Set the 'A' COUPLING switch at AC, and the 'A' SOURCE switch at UPPER BEAM. The approximate voltage at pin 7 of V125 is  $-55$  volts. Connect a dc voltmeter at this test point (see Figure 6-2) and rotate the 'A' STABILITY control counterclockwise until the upper beam sweep just stops free-running. Record the meter reading of the dc voltmeter. Set the 'A' SWEEP FUNCTION switch at SINGLE SWEEP and trigger the sweep once by rotating the 'A' LEVEL control clockwise to + and then counterclockwise to -. If the 'A' STABILITY control setting is correct as explained above, the READY lamp should extinguish indicating that the upper beam trace is locked out. Now set the 'A' LOCK OUT LEVEL ADJ. control for a voltmeter reading of 11 volts lower (less negative) than the previous reading. To compare voltmeter readings, repeat the procedure given in this step.



Fig. 6-3. Waveforms 1, 2 and 3 show changes in the waveform as the TRIGGER SENS. control is rotated clockwise. Waveform 4 is the display obtained when the control is adjusted correctly.

**'A' Stability**

Set the 'A' SWEEP FUNCTION switch at NORMAL. Set the 'A' trigger controls at + SLOPE, LINE SOURCE, and rotate the LEVEL control fully counterclockwise to the AC AUTO. position. The voltage reading at the junction of the 'A' STABILITY wiper arm and R114 is approximately  $-80$  to  $-110$  volts. Connect a dc voltmeter at this junction (see Figure 6-4) and rotate the 'A' STABILITY control fully counterclockwise. Turn the 'A' STABILITY control clockwise until the upper beam trace first appears. Record the reading of the dc voltmeter. Then continue to rotate the 'A' STABILITY control clockwise until the upper beam trace brightens and again record the voltage. Set the 'A' STABILITY control for a voltmeter reading midway between the two recorded voltage readings. (See Figure 6-4.) Disconnect the voltmeter leads and plug-in extension. Reinstall the Type 21 in the TIME BASE A compartment.

**NOTE**

The 'B' triggering adjustments that follow must be made in the indicated sequence. Controls not mentioned in a particular step are assumed to be in the positions they were last in during the previous step. Although the Type 21 Time Base Unit is shown in the illustrations, the same physical locations of the adjustments and test points apply to the Type 22 Time Base Unit.

**'B' Trigger Level**

Remove the Type 22 Time Base Unit, attach the Time Base Plug-In Extension to the Type 22 Unit, and install the unit with the extension in the TIME BASE B compartment of the Type 555.

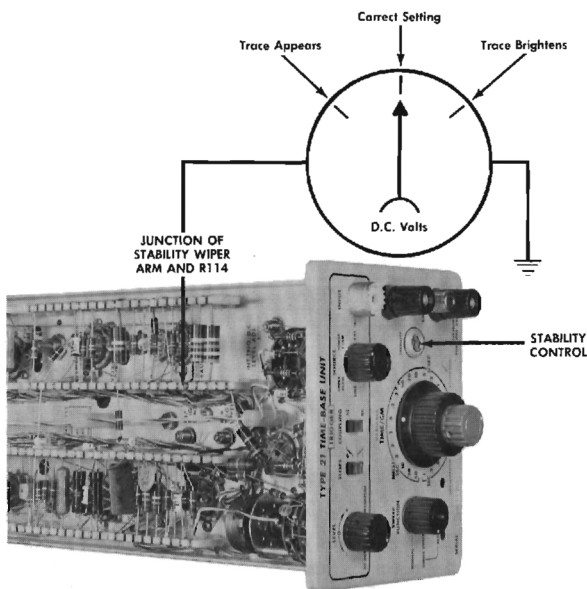

Fig. 6-4. Adjustment of the STABILITY control.

Set the Lower Beam HORIZ. DISPLAY switch at 'B' X1. Place the 'B' SLOPE switch at +, 'B' COUPLING switch at DC, and 'B' SOURCE switch at LOWER BEAM. Rotate the 'B' LEVEL control to zero. Set the upper beam vertical plug-in unit VOLTS/CM switch at .05 and the input selector AC-DC switch at DC. Place the Upper Beam HORIZ. DISPLAY switch at 'A' X1. Set the 'A' trigger controls at AC AUTO., + SLOPE, AC COUPLING, and LINE SOURCE. Place the 'A' SWEEP FUNCTION switch at NORMAL and the 'A' TIME/CM switch at 2 MILLISEC. Center the upper beam trace at the upper horizontal centerline of the graticule and connect the 10X probe from the upper beam vertical input connector to the junction of R19 and R20 (see Figure 6-2). If the probe is being used with the clip lead ungrounded, position the probe body away from the 'B' SOURCE switch leads to prevent any feedback of signals. Rotate the 'B' LEVEL knob until the upper beam trace is at the upper horizontal centerline. Loosen the 'B' LEVEL knob and set it at zero position. Retighten the knob and recheck it for exact zero setting and no vertical shift of the upper beam trace by disconnecting and connecting the probe a few times at the junction. Disconnect the probe from the junction.

**'B' Lower Beam Internal Trigger DC Level**

Set the 'B' TIME/CM switch at .1 MILLISEC and rotate the 'B' STABILITY control clockwise for a free-running sweep. Position the lower beam trace to the lower horizontal centerline. Connect a short jumper from the junction of R19 and R20 to the chassis; connect a dc voltmeter from the junction of R22 and SW22 to the chassis. (See Figure 6-2). Place the 'B' SLOPE switch in the  $-$  position and adjust the 'B' LOWER BEAM INT. TRIG. D.C. LEVEL ADJ. control for a voltmeter reading of zero volts. Slide the SLOPE switch from  $-$  to  $+$  to check for no voltmeter needle shift. Leave the SLOPE switch at  $-$ .

**'B' Upper Beam Internal Trigger DC Level**

Position the upper beam trace to its centerline. Set the 'B' SOURCE switch at UPPER BEAM. Adjust the 'B' UPPER BEAM INT. TRIG. D.C. LEVEL ADJ. control for a voltmeter reading of zero volts and no change in meter needle movement when the 'B' SOURCE switch is set at LOWER BEAM and back to UPPER BEAM. Disconnect the voltmeter.

**'B' Trigger Level Centering**

Rotate the upper beam vertical plug-in VOLTS/CM switch to the .5 volt position and set the input selector AC-DC switch at AC. Set the 'B' SOURCE switch at LINE. Connect the probe to pin 6 of V45 (see Figure 6-2) and preset the 'B' TRIG. SENS. control to the center of its rotation. Adjust the 'B' TRIG. LEVEL CENT. control so that the waveform on the upper beam is symmetrical. For precise adjustment set the Upper Beam HORIZ. DISPLAY switch at 'A' X.2 and horizontally center the + slope or switching portion of the multivibrator waveform using the 'A' HORIZ. POSITION control. Now slide the 'B' SLOPE switch up and down from  $-$  to  $+$  and, at the same time, readjust the 'B' TRIG. LEVEL CENT. for no horizontal shifting of the switching of the waveform. Leave the 'B' SLOPE switch at  $+$ .

## 'B' Trigger Sensitivity

With the probe and jumper connected as described in the previous step, rotate the 'B' TRIG. SENS. control fully counterclockwise. Turn the control slowly clockwise and stop at the point where the oscillations cease to appear. Note the amplitude of the spike on the top corner of the multivibrator waveform. Then rotate the 'B' TRIG. SENS. control clockwise until this spike is slightly less than one half of the original size (see Figure 6-3). Disconnect the probe from the test point and remove the jumper lead.

## 'B' Lockout Level

Set the 'B' COUPLING switch at AC and the 'B' SOURCE switch at LOWER BEAM. The approximate voltage at pin 7 of V125 is  $-55$  volts. Connect a dc voltmeter at this point (see Figure 6-2) and rotate the 'B' STABILITY control counterclockwise until the lower beam sweep just stops free-running and record the meter reading of the dc voltmeter. Set the 'B' SWEEP FUNCTION switch at SINGLE SWEEP and trigger the sweep once by rotating the 'B' LEVEL control clockwise to  $+$  and then counterclockwise to  $-$ . If the 'B' STABILITY control setting is correct as explained above, the READY lamp should extinguish indicating that the lower beam trace is locked out. Now, set the 'B' LOCKOUT LEVEL ADJ. control for a voltmeter reading of 11 volts lower (less negative) than the previous reading. If you wish to compare voltmeter readings, repeat the procedure given in this step.

## 'B' Stability

Set the 'B' SWEEP FUNCTION switch at NORMAL. Set the 'B' trigger controls at  $+$ SLOPE, LINE SOURCE, and rotate the LEVEL control fully counterclockwise to the AC AUTO. position. The voltage reading at the junction of the 'B' STABILITY wiper arm and R114 is approximately  $-80$  to  $-110$  volts. Connect a dc voltmeter at this junction (see Figure 6-4) and rotate the 'B' STABILITY control fully counterclockwise. Turn the 'B' STABILITY control clockwise until the lower trace beam first appears. Record the reading of the dc voltmeter. Then continue to rotate the 'B' STABILITY control clockwise until the lower beam trace brightens and again record the voltage. Set the 'B' STABILITY control for a voltmeter reading midway between the two recorded voltage readings. (See Figure 6-4). Disconnect the voltmeter lead and plug-in extension. Reinstall the Type 22 in the Time Base B Compartment.

## Beam Rotation

Set both beams for free-running sweeps by setting the LEVEL controls of both time base units to RECURRENT and the SWEEP FUNCTION switches at NORMAL. Position the beam traces behind the appropriate horizontal centerlines of the graticule. Adjust the BEAM ROTATION control so that the traces are parallel to the horizontal centerlines. The final setting of the BEAM ROTATION control should be near the center of its rotation range. You may find it necessary to loosen the crt base socket clamp (see Figure 6-10)

and rotate the crt a few degrees in the direction that will achieve this final mid-range setting. Retighten the socket clamp.

## Positioning the Graticule

With the control settings remaining as in the previous step, position the upper beam trace upward until the trace dims and then downward until the trace again becomes dim. Note the distance that the beam moved and position it to the middle of this distance. Remove the graticule cover and loosen the set screw which holds the nylon cam in the graticule slot. Rotate the cam with an allen wrench or a pointed tool and position the graticule until the upper beam graticule centerline coincides with the upper beam. While holding the cam with the tool, tighten the set-screw.

Follow the same procedure to determine the center of the lower beam viewing area. If the centered lower beam is not close to the centerline, re-position the graticule to obtain a compromise setting for the two beams. Replace the graticule cover.

## Astigmatism Balance\*

Lay the indicator unit on its side. Connect a dc voltmeter from the junction of R1054 and C1054 to the junction of R2054 and C2054 (see Figure 6-5.) Adjust the ASTIG. BAL. control for zero reading on the dc voltmeter.

## Upper Beam Vertical D.C. Shift Compensation

Place the 'A' TIME/CM at 2 SEC. Rotate the 'A' LEVEL control full right to the RECURRENT position and set the vertical input AC-DC selector switch at DC. Intermittently apply the probe to the  $+100$  v test point (see Figure 6-5), or other regulated dc supply, and set the Upper Beam vertical sensitivity to obtain about 3 cm deflection. Look for a slow rise or a slow fall of the beam with a time constant of one or two seconds. If necessary, adjust the Upper Beam D.C. SHIFT control until the spot comes immediately to the final level without drifting either up or down after each time the probe is applied.

## Lower Beam Vertical D.C. Shift Compensation

Follow the same procedure as given in the previous step by using the Lower Beam and time base 'B' controls. The location of the Lower Beam VERTICAL D.C. SHIFT adjustment is shown in Figure 6-5.

## Upper and Lower Astigmatism

Rotate both FOCUS controls fully clockwise and place both HORIZ. DISPLAY switches at the X10 EXT. ATTEN. position. Position both beams onto the screen, and adjust the UPPER ASTIG. and LOWER ASTIG. controls so that both de-

\* Make this adjustment on instruments having serial numbers lower than 220. Omit this step on instruments having serial numbers 220 or higher because the control has been removed.

## Internal Adjustments — Type 555

focused spots are as nearly circular as is possible. Adjust the FOCUS controls so that both spots are in sharp focus. To sharpen the focus further, place both HORIZ. DISPLAY switches at 'A' X1. Set both time base trigger controls at AC AUTO., +SLOPE, AC COUPLING, and UPPER BEAM SOURCE. Rotate the TIME/CM controls to the .5 MILLISEC position. Set the vertical plug-in VOLTS/CM controls at 1, the input selector AC-DC switches at AC, and position both beams to the appropriate horizontal center lines. Connect a 1-volt signal from the AMPLITUDE CALIBRATOR to both upper and lower beam vertical input connectors. Carefully readjust the Upper Beam FOCUS and UPPER ASTIG. controls for a sharper focus of the leading corner of one square-wave on the upper beam calibrator waveform. Adjust the Lower Beam FOCUS and LOWER ASTIG. controls for the same results on the lower beam calibrator waveform.

## Geometry Adjustments 1 and 2

Place all controls in the positions they were in at the completion of the UPPER and LOWER ASTIGMATISM adjustments and leave the calibrator signal connected. Rotate the AMPLITUDE CALIBRATOR to the 10-volt position. Increase the

intensity of both beams to allow the rising and falling portions of the waveforms to be visible. The tops and bottoms of the square-waveforms should extend beyond the usable viewing area of the beams. Horizontally align the rising and falling portions of the upper beam waveform with those of the lower beam by using the horizontal positioning controls. Adjust the GEOM. ADJ. 1 and GEOM. ADJ. 2 for minimum curvature and best vertical alignment of the vertical trace lines at the edges of the graticule (see Figure 6-6). Decrease the intensity of both beams to normal intensity and rotate the AMPLITUDE CALIBRATOR to the OFF position. Vertically position each beam 2 centimeters above and 2 centimeters below the appropriate centerline and check for excessive bowing of the horizontal trace. The bowing of the horizontal traces is minimized by a slight readjustment of either or both GEOM. ADJ. 1 and GEOM. ADJ. 2 controls.

## Upper Beam Sweep Magnified Registration

The control settings that follow apply to the Upper Beam and Time Base A. Place the HORIZ. DISPLAY switch at 'A' X1. Set the trigger controls at AC AUTO., +SLOPE, AC COUPLING, and UPPER BEAM SOURCE. Set the SWEEP

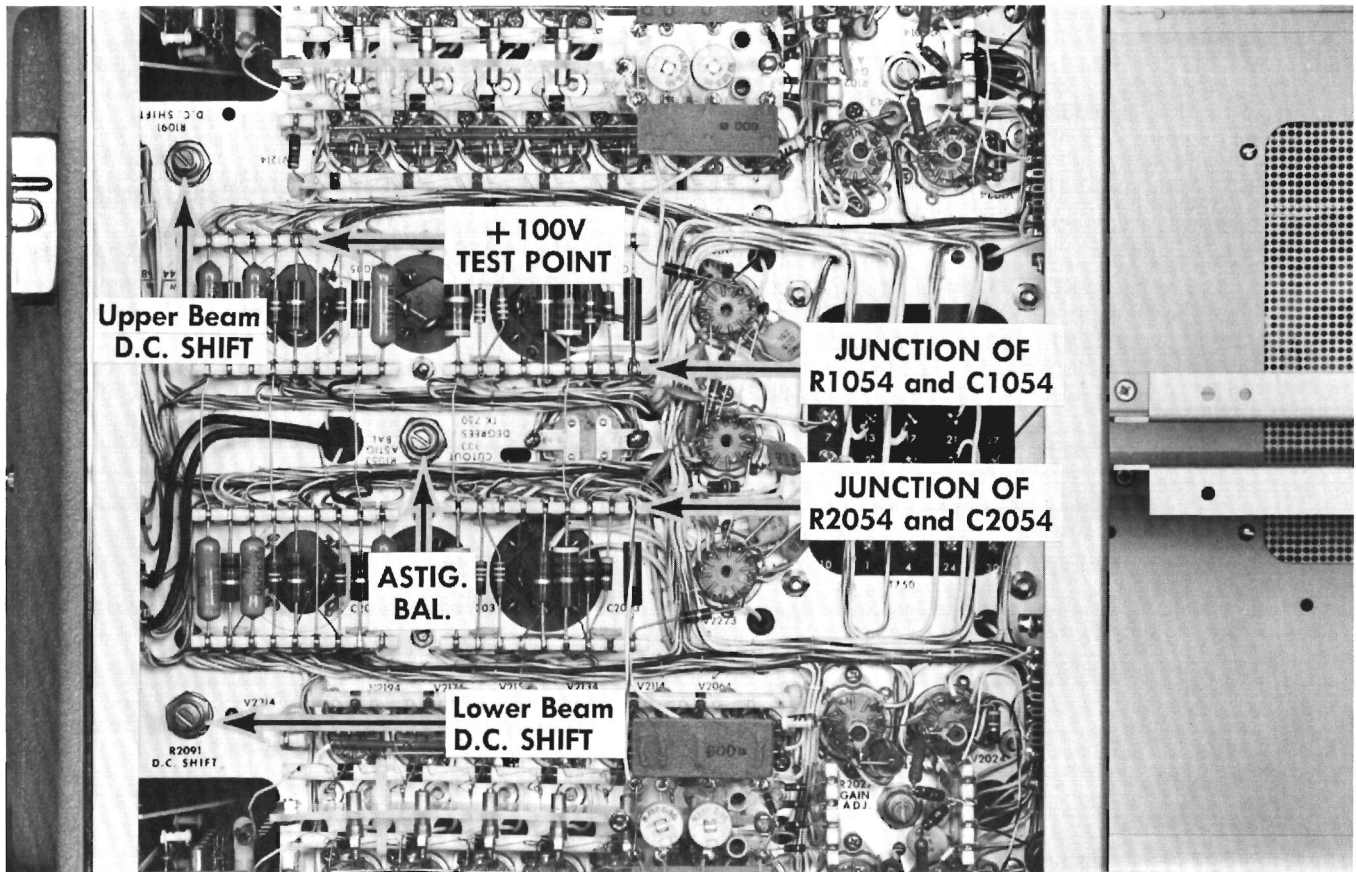

Fig. 6-5. Bottom view of indicator unit showing location of ASTIB. BAL. control\* and the test point junctions. Locations of the +100 V test point and D.C. SHIFT adjustments are shown also.

\* Make this adjustment on instruments having serial numbers lower than 220. Omit this step on instruments having serial numbers 220 or higher because the control has been removed.

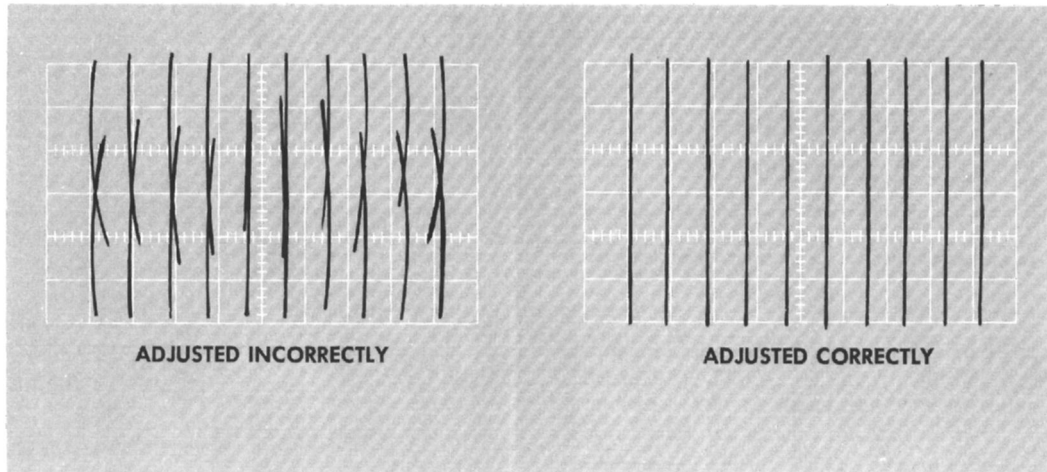

Fig. 6-6. Adjustment of the GEOMETRY controls.

FUNCTION switch at NORMAL and rotate the TIME/CM control to the .2 MILLISEC position. Set the vertical plug-in VOLTS/CM at 1, the AC-DC switch at DC, and position the upper beam trace to the upper horizontal centerline. Place the AMPLITUDE CALIBRATOR control at 2 volts and connect the calibrator signal from the CAL. OUT connector to the vertical plug-in input connector. Place the HORIZ. DISPLAY switch at 'A' X2. Position the trace so that the leading edge of the first square-wave is at the vertical centerline of the graticule. Then place the HORIZ. DISPLAY switch in the 'A' X1 position and adjust the SWP. MAG. REGIS. control (see Figure 6-10) until the leading edge of the first square-wave is again at the vertical centerline of the graticule. The leading edge of the square-wave should then remain stationary

as the HORIZ. DISPLAY switch is moved from the 'A' X1 to the 'A' X2 position (see Figure 6-7). Disconnect the calibrator signal.

### Lower Beam Sweep Magnified Registration

The control settings that follow for this adjustment apply to the lower beam and Time Base B. Place the HORIZ. DISPLAY switch at 'B' X1. Set the trigger controls at AC AUTO., +SLOPE, AC COUPLING, and LOWER BEAM source. Set the SWEEP FUNCTION switch at NORMAL and rotate the TIME/CM control to the .2 MILLISEC position. Set the vertical plug-in VOLTS/CM at 1, the AC-DC switch at DC, and position the lower beam trace to the lower horizontal centerline. Place the AMPLITUDE CALIBRATOR control at 2 volts and connect the calibrator signal from the CAL. OUT connector to the vertical plug-in input connector. Place the HORIZ. DISPLAY switch at 'B' X2. Position the trace so that the leading edge of the first square-wave is at the vertical centerline of the graticule. Then place the HORIZ. DISPLAY switch in the 'B' X1 position and adjust the SWP. MAG. REGIS. control (see Figure 6-10) until the leading edge of the square-wave is again at the vertical centerline of the graticule. The leading edge of the square-wave should then remain stationary as the HORIZ. DISPLAY switch is moved from the 'B' X1 to the 'B' X2 position (see Figure 6-7). Disconnect the calibrator signal.

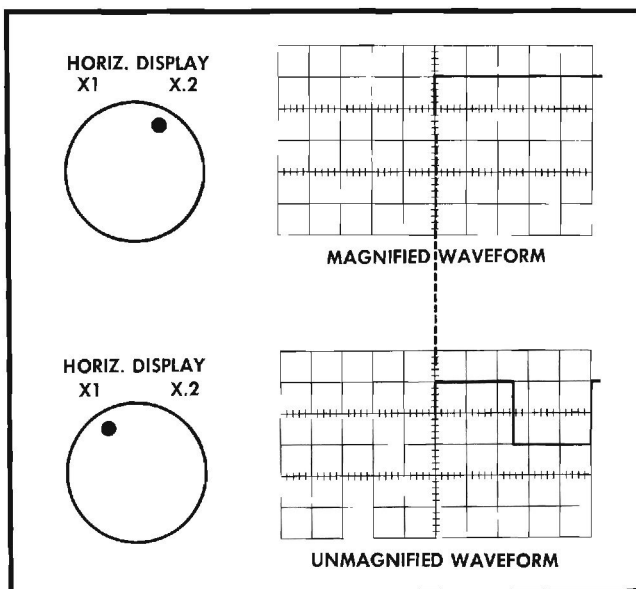

Fig. 6-7. When the adjustment of the SWP. MAG. REGIS. controls are made properly, the portion of the displayed waveform at the exact center of the graticule remains stationary as the appropriate HORIZ. DISPLAY switch is switched between the X1 and the X2 positions.

### 'A' Sweep Length

Remove the Type 21 Time-Base Unit, attach the Time Base Plug-In Extension, and install the Type 21 with the extension in the 'A' plug-in compartment.

With controls set as in the Upper Beam Sweep Magnified Registration step, place the 'A' TIME/CM switch at .1 MILLI-SEC and rotate the 'A' LEVEL control fully clockwise to the RECURRENT position. Place the Upper Beam HORIZ. DISPLAY switch at 'A' X1 and adjust the 'A' SWEEP LENGTH control for a sweep length of 10.5 centimeters. Remove the Type 21 Time-Base Unit and the plug-in extension connector. Re-install the Type 21.

## Internal Adjustments — Type 555

### 'B' Sweep Length

With the controls set as in the Lower Beam Sweep Magnified Registration step, place the 'B' TIME/CM switch at .1 MILLISEC and rotate the 'B' LEVEL control fully clockwise to the RECURRENT position. Place the Lower Beam HORIZ. DISPLAY switch at 'B' X1 and adjust the 'B' SWEEP LENGTH (see Figure 6-9) control for a sweep length of 10.5 centimeters.

### Upper Beam External Horizontal Amplifier D.C. Balance

Place the Upper Beam vertical plug-in VOLTS/CM switch at 20 volts. Connect a jumper from 'A' SAWTOOTH to the vertical INPUT, place the Upper Beam HORIZ. DISPLAY switch at EXT. ATTN. X1 and rotate the 'A' LEVEL control full right to the RECURRENT position. Turn the Upper Beam HORIZ. POSITION control to the left to position the upper beam vertical trace to the left graticule line. Adjust the Upper Beam HORIZ. AMP. D.C. BAL. control (see Figure 6-8) for no horizontal shift of the trace while rotating the Upper Beam EXT. HORIZ. GAIN control.

### Check Upper Beam Ext. Horiz. Input Deflection Factor

With controls set as given in the previous step, connect a jumper from the CAL. OUT to the Upper Beam EXT. HORIZ. INPUT connector. Set the AMPLITUDE CALIBRATOR at .2 VOLTS and turn the EXT. HORIZ. GAIN control full right. At least one centimeter of horizontal deflection must be displayed. Increase the AMPLITUDE CALIBRATOR to 2 volts and adjust the EXT. HORIZ. GAIN control for exactly 10 cm of horizontal deflection. Place the Upper Beam HORIZ. DISPLAY switch at EXT. ATTN. X10. The horizontal deflec-

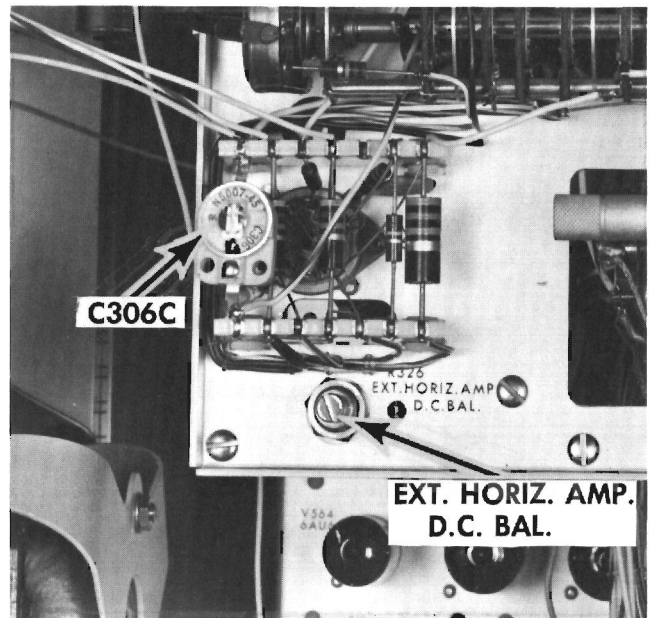

Fig. 6-8. Location of the upper beam external horizontal amplifier adjustments.

tion should now be one centimeter. (Attenuator accuracy  $\pm 3\%$ ).

### External Horizontal Input Compensation

With the jumpers connected as described in the two previous steps, set the AMPLITUDE CALIBRATOR at 5 VOLTS. Connect a third jumper from the CAL. OUT to the 'A' trigger INPUT connector. Set the Upper Beam and 'A' controls as follows:

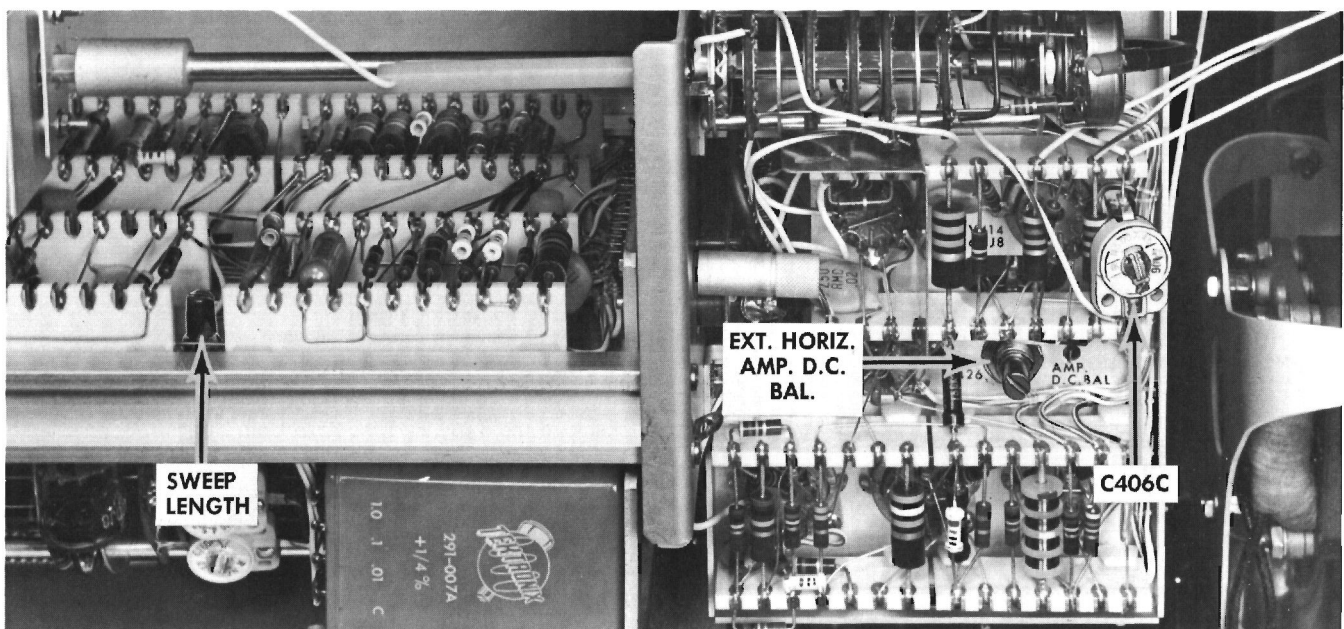

Fig. 6-9. Location of the lower beam SWEEP LENGTH and external horizontal amplifier adjustments.

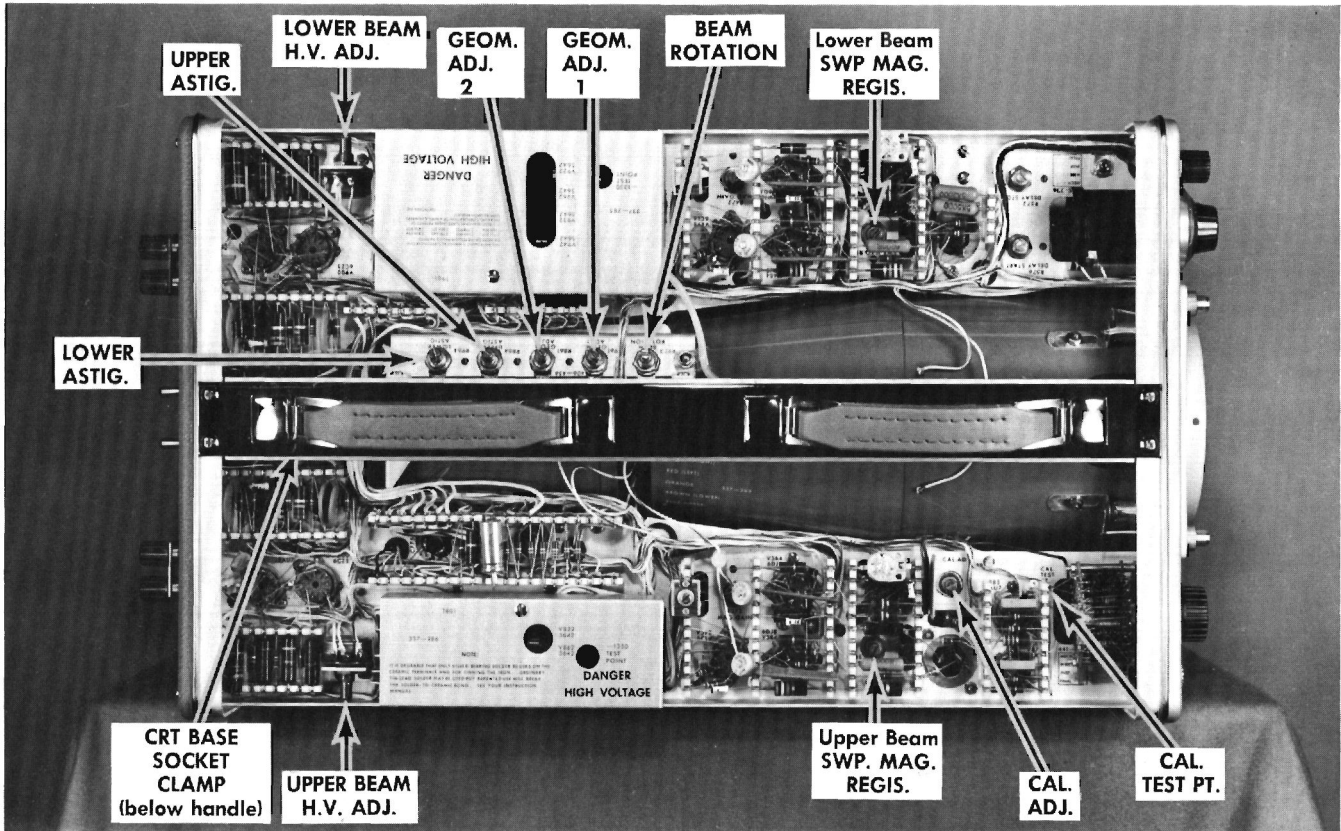

Fig. 6-10. Top view location of the internal adjustments, CAL. TEST PT., and crt socket clamp.

HORIZ. DISPLAY (Upper Beam)	EXT. ATTEN. X1
SLOPE	—
FUNCTION	NORMAL
TIME/CM	1 MILLISEC
VOLTS/CM (Vertical Plug-In)	10

Adjust the 'A' LEVEL control for a stable square-wave, displayed vertically. Adjust C306C (see Figure 6-8) for optimum flat top. Disconnect all jumper leads.

### Lower Beam External Horizontal Amplifier Adjustments

Follow the same procedure as given in the last three steps by using the corresponding Lower Beam and time base 'B' front panel controls. Locations of the internal controls are shown in Figure 6-9. The capacitor, C406C, is adjusted in the same manner as C306C. The adjustment of C306C is explained in the previous step.

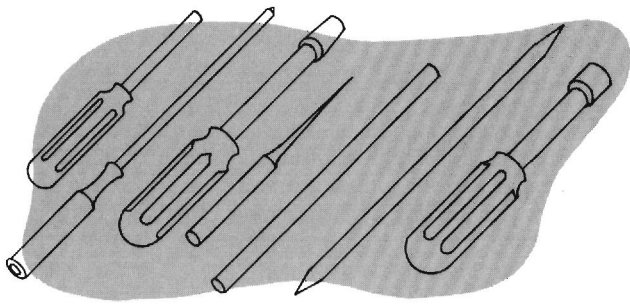

# SECTION 7

## CALIBRATION PROCEDURE

The Type 555 Oscilloscope is a stable instrument and should not require frequent calibration. However, it will be necessary to calibrate certain parts of the instrument when tubes or components are changed, and periodic calibration is desirable from the standpoint of preventive maintenance.

In the instructions that follow, the steps are arranged in the proper sequence for full calibration. Each numbered step contains the information necessary to make one adjustment. Sometimes, two or more adjustments are included in one step when the controls to be adjusted are related to each other and if several adjustments can be made easily at that time. If a complete calibration is not necessary, you may perform individual steps, **PROVIDING** that the steps performed do not affect other adjustments. It is important that you are fully aware of the interaction of adjustments. Generally speaking, the interaction of controls will be apparent in the schematic diagrams. If you are in doubt, check the calibration of the entire section on which you are working.

If you make any adjustments on the power supplies, you will have to check the calibration of the entire instrument. In particular the sweep rates and vertical deflection factors must be checked.

### EQUIPMENT REQUIRED

The following equipment is necessary for a complete calibration of the Type 555 Oscilloscope:

- (1.) A DC voltmeter having a sensitivity of at least 5000  $\Omega/v$  and calibrated for an accuracy of at least 1% at 100, 150, 225, 350 and 500 volts, and for an accuracy of at least 3% at 1350 volts. Portable multimeters should be regularly checked against an accurate standard and corrected readings noted, where necessary, at the above listed voltages. **BE SURE YOUR METER IS ACCURATE.**
- (2.) An accurate rms-reading ac voltmeter, having a range of 0-150 volts. (0-250 or 0-300 for 234 v operation).
- (3.) AC voltmeter with a range of zero to 10 volts RMS of the iron vane or dynamometer type.
- (4.) Variable autotransformer (e.g. Powerstat or Variac) having a rating of at least 1.3 KVA.
- (5.) Time-mark Generator, Tektronix Type 180, 180A or equivalent, having markers at 1  $\mu\text{sec}$ , 10  $\mu\text{sec}$ , 50  $\mu\text{sec}$ , 100  $\mu\text{sec}$ , 1 msec, 10 msec, 100 msec, 1 sec, and 5 sec and sine-wave outputs of 10 mc and 50 mc, all having an accuracy of at least 1%.
- (6.) Constant-Amplitude Signal Generator, Tektronix Type 190 or 190A, or equivalent, providing a 200 mv signal at

constant amplitude through the frequency range of 500 kc to over 30 mc.

(7.) Square-Wave Generator, Tektronix Type 107 or equivalent, having a risetime of no more than 4 seconds, and a frequency of approximately 500 kc. The top of the square-wave must be free of overshoot and wrinkles. A Tektronix Type P Unit may be used in place of the Type 107. A Type P52 coaxial cable and 50-ohm Terminating Resistor is required with the Type 107.

(8.) Tektronix Type K or Type L Plug-In Unit. (If delay-line adjustment is not required, other Tektronix Plug-In Units may be substituted.)

(9.) Low-Capacitance Calibration Tools. See Fig. 7-1.

(10.) Tektronix Type P410A or P6000 Probe.

(11.) Clip-lead adaptor (013-003) and a 1 k,  $\frac{1}{2}$  w, composition resistor.

(12.) Gain Set Adaptor, Tektronix Type EP53A.

(13.) Two Time-Base Plug-In Extensions.

(14.) The Type 555 is used as a test oscilloscope by using single-beam operation to make some of the adjustments.

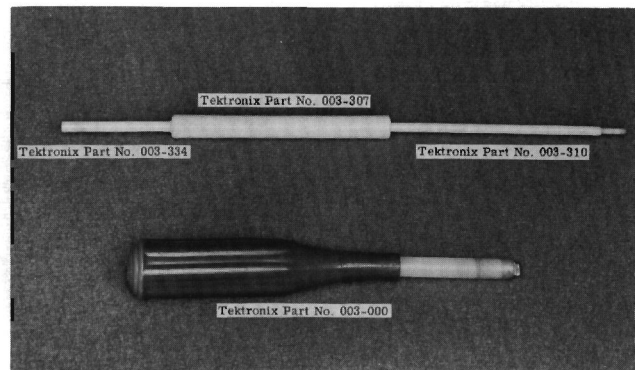

Fig. 7-1. Suggested calibration tools used to calibrate the Type 555 Oscilloscope.

### ADJUSTMENT PROCEDURE

#### Preliminary

Remove the side covers and bottom plate from the Power Supply and Indicator Units to be calibrated. Install the

## Calibration Procedure—Type 555

Type K or Type L Unit in the Upper Beam compartment. Set the front-panel controls for both beams as follows:

INTENSITY	full left
HORIZ. DISPLAY (Upper Beam)	'A' X1
HORIZ. DISPLAY (Lower Beam)	'B' X1

### TIME-BASE UNITS

LEVEL (Type 21 and 22)	full left, but not AC AUTO.
SLOPE (Type 21 and 22)	+
COUPLING (Type 21 and 22)	AC
(Type 21) SOURCE	UPPER BEAM
(Type 22) SOURCE	LOWER BEAM
SWEEP FUNCTION (Type 21 and 22)	NORMAL
TIME/CM (Type 21 and 22)	.5 MILLISEC
VARIABLE (Type 21 and 22)	CALIBRATED (full right)

### VERTICAL PLUG-IN UNITS

AC/DC	DC
VOLTS/CM	.05
VARIABLE	CALIBRATED (full right)

Check the rear panel of the instrument to be sure the metal strap between the CRT CATHODE and GROUND binding posts for both beams are in place, and that the CRT CATHODE selector switches are at the CRT CATHODE position. Connect the instrument and the (0-150 or 0-300 volt) ac meter to the autotransformer output and turn on all equipment. Adjust the autotransformer to the design-center voltage for which your instrument is wired (117 or 234 v) and allow at least 5 minutes warmup before making any adjustments.

## 1. Low-Voltage Power Supplies

Measure the output voltage of the  $-150$  v,  $+100$  v,  $+225$  v,  $+350$  v and  $+500$  v supplies at the points indicated on the Power Supply Unit (see Figure 7-2). Be sure your meter is accurate (see Equipment Required, (1)). The output voltage of the  $-150$  v supply must be between  $-147$  v and  $-153$  v, and the other regulated supplies must be within 2% of their rated values. You should be able to set the  $-150$  ADJ. control (see Power Supply Unit, Figure 7-3) so that all of these voltages are within the specified tolerance. Bear in mind that the calibration of the entire instrument is effected by changes in the power supply voltages. Don't adjust the  $-150$  v unless one or more of the supplies is actually out of tolerance.

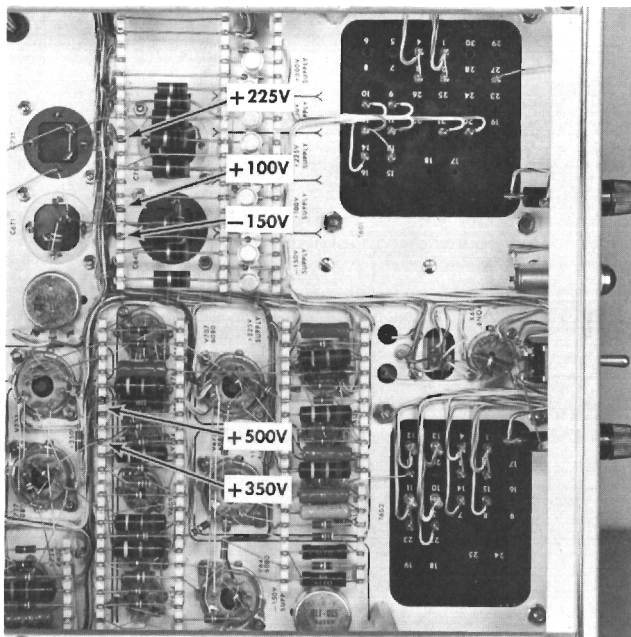

Fig. 7-2. Bottom view of the power supply showing the location of the test points.

### NOTE

Settings for all controls not listed above are not pertinent to this part of the procedure and the controls may be left in any position. The letter 'A' is used throughout the procedure as an abbreviation for "TIME BASE A" and the letter 'B' for "TIME BASE B".

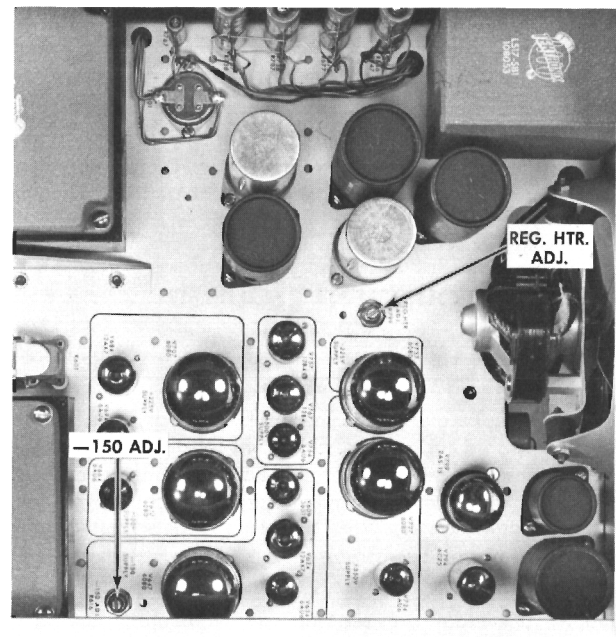

Fig. 7-3. Top view of the power supply unit showing location of the power supply unit adjustments.

Connect the 0-10 volt ac meter between the test point shown in Figure 7-4 and ground. Adjust the Reg. Htr. Adj. for a voltage reading of 6.3 VAC.

To check the above supplies for proper regulation, vary the autotransformer voltage between 105 v and 125 v (or from 210 v to 250 v if the power transformer is connected for 234 v operation). All of the regulated voltages should remain essentially constant.

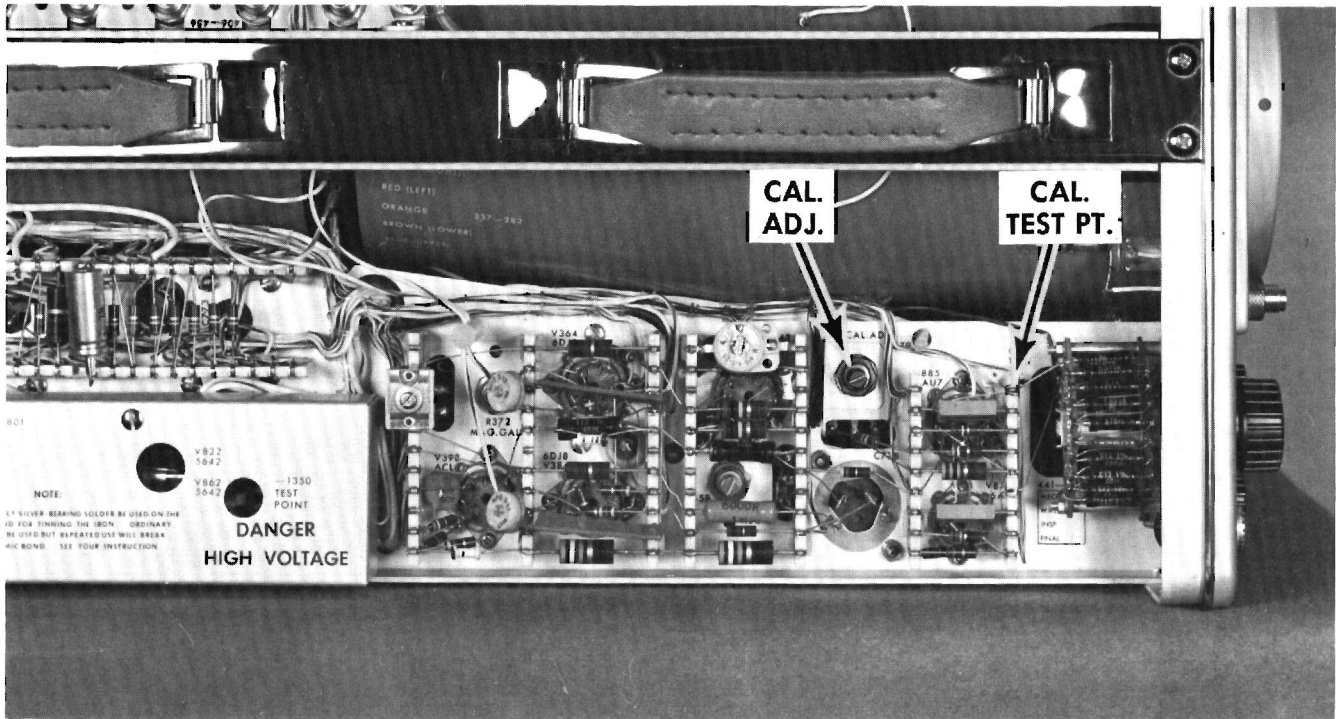

Fig. 7-4. Top view of indicator unit showing the location of the CAL. ADJ. control and the CAL. TEST PT.

The ripple present on any of the dc regulated supplies, as measured with one beam of the oscilloscope at the voltage check points, will be under 10 mv., with the CALIBRATOR-OFF, and the sweep for the other beam not operating. When using the one beam for ripple measurements, place the TIME/CM control at 5 MILLISEC, the LEVEL control at AC AUTO., the SOURCE switch at LINE, and the vertical input selector AC-DC switch to AC. Use the coaxial cable and clip-lead adaptor to connect the outer conductor to ground (chassis) and the center conductor to each test point. If the oscillations occur on the waveform, connect a 1 K resistor in series with the clip-lead center conductor.

## 2. Amplitude Calibrator Adjustment

The Cal. Adj. control should be set to provide a dc output of 100 volts when the AMPLITUDE CALIBRATOR switch is in the OFF position. Under these conditions, the calibrator output will be within 3% of the front-panel readings.

To make this adjustment connect the voltmeter between the Cal. Test Pt. jack and ground (see Figure 7-4), turn the AMPLITUDE CALIBRATOR switch to the OFF position, and adjust the Cal. Adj. control for a reading of exactly 100 volts. To assure suitable symmetry of the calibrator waveform, the reading at this point should not be less than 45 volts nor more than 55 volts when the calibrator is turned on (to any of the output voltage settings). Readings outside this range are generally caused by unbalanced multivibrator tubes (V875 or V885).

## 3. High-Voltage Power Supply Adjustment

These adjustments determine the total accelerating potentials on the crt, and thus affect the deflection sensitivity.

Connect the dc voltmeter between ground and the upper beam high-voltage check point (see Figure 7-5), and set the Upper Beam H.V. Adj. for a meter reading of exactly —1350 volts. If your meter has a full scale reading of 1200 v, you can connect the positive meter lead to the —150 v supply, at any convenient point, and set the Upper Beam H.V. Adj. for a meter reading of —1200 v.

Connect the dc voltmeter between ground and the Lower Beam High-Voltage check point (see Figure 7-5), and set the Lower Beam H.V. Adj. for a meter reading of exactly —1350 volts. If your meter has a full scale reading of 1200 v, connect your meter as described in the previous paragraph.

## 4. Beam Rotation

If the crt has been replaced, or if, due to considerable handling, the trace does not align with the graticule, you should make this adjustment before proceeding with the calibration.

Set both beams for free-running sweeps by setting the LEVEL control of both time-base units to RECURRENT. With no vertical signals applied, position the beam traces behind the appropriate horizontal centerlines of the graticule. Adjust the Beam Rotation control (see Figure 7-5) so that the

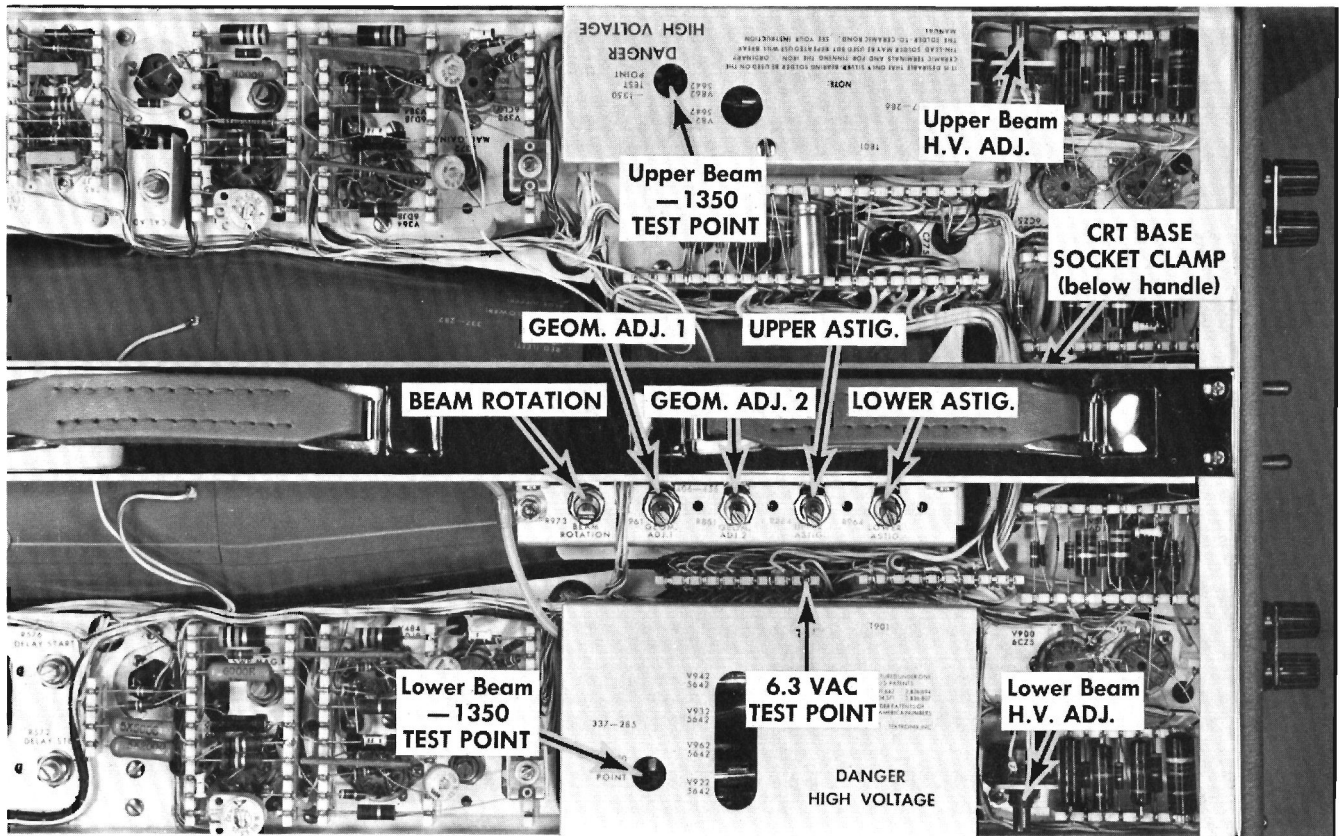

Fig. 7-5. Top view, rear section, showing the location of the test points, control adjustments, and crt socket clamp.

traces are parallel to the horizontal centerlines. The final setting of the Beam Rotation control should be near the center of its rotation range.

If the Beam Rotation control is not near the center of its rotation range, loosen the crt base connector clamp and rotate the crt a few degrees in the direction which will achieve this final mid-range setting. While aligning the crt, push it forward until it rests snugly against the graticule, and tighten the connector clamp. Recheck the alignment of the traces.

### 5. Graticule Alignment

With the control settings as in the previous step, position the upper beam trace upward until the trace dims, and then downward until the trace again becomes dim. Note the distance that the beam moved and position the beam midway between the two points. Remove the graticule cover. Loosen the screw which holds the nylon cam located in the lower left corner of the graticule. Rotate the cam with an allen wrench or a pointed tool and position the graticule until the upper beam graticule centerline coincides with the upper beam. While holding the cam with the tool, tighten the screw.

Follow the same procedure to determine the center of the lower beam viewing area. If the center lower beam is not

close to the centerline, re-position the graticule to obtain a compromise setting for the two beams. Replace the graticule cover.

### 6. Astigmatism Balance SN 101 to 220

Connect a dc voltmeter from the junction of R1054 and C1054 to the junction of R2054 and C2054 (see Figure 7-6). Adjust the Astig. Bal. control for zero reading on the dc voltmeter.

### 7. Interplate Shield Voltage Adj. SN 996 and up

Adjust the Interplate Shield Voltage Adj. (R863) until a vertical crt sensitivity of 7 v/cm is obtained. The adjustment is made by first connecting a DC voltmeter with one lead on each of the crt's LOWER BEAM vertical plates. Position the LOWER BEAM trace, which should be free running, to the appropriate center graticule line. Observe the voltmeter reading and then position the LOWER BEAM trace to the bottom graticule line. Again read the voltmeter. If R863 is properly adjusted a difference of fourteen volts should have been obtained, giving the crt a vertical sensitivity of 7 volts/cm. If this is not the case the pot will have to be adjusted again and the sensitivity checked until the proper reading is obtained.

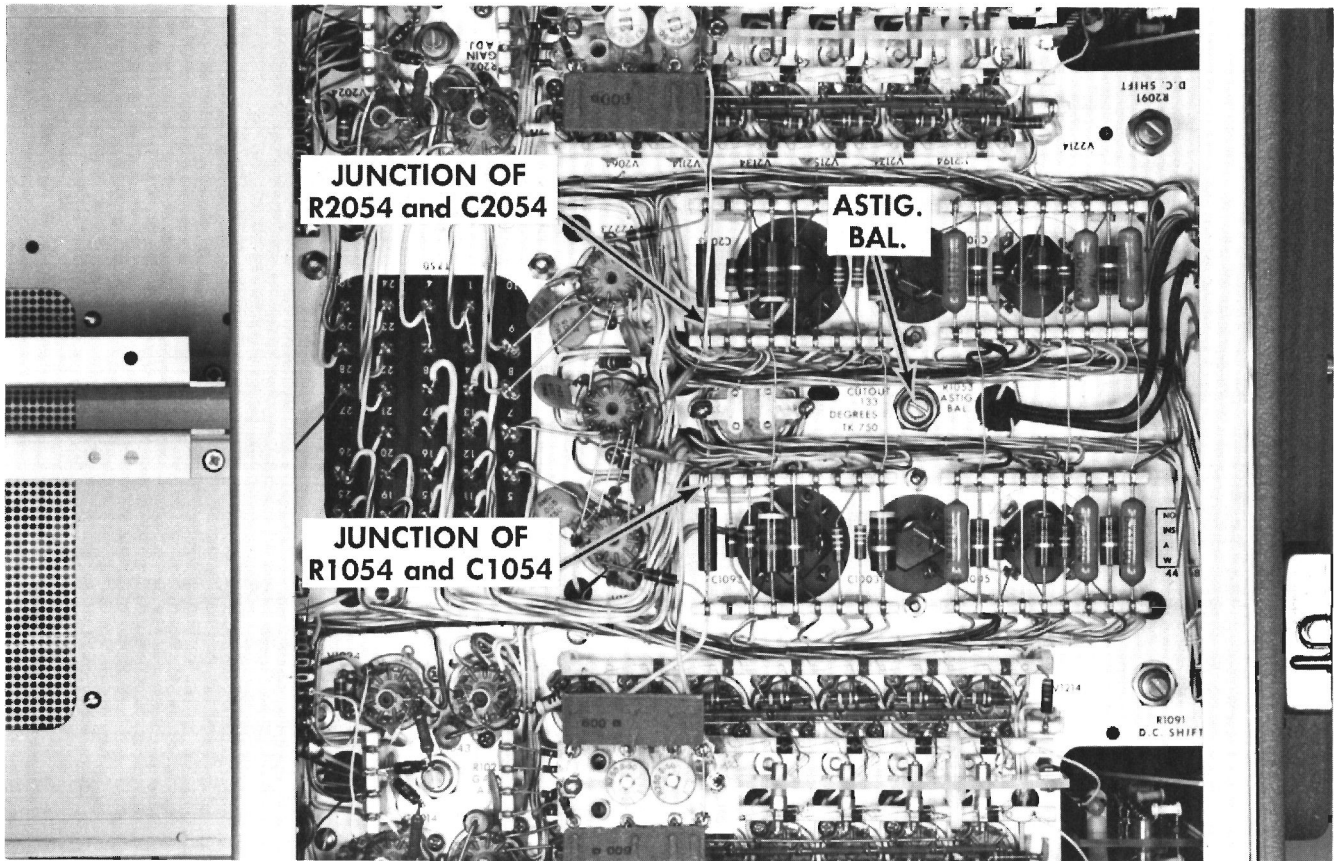

Fig. 7-6. Bottom view of indicator unit showing the location of the ASTIG. BAL. control and the junction test points.\* (See step 6, Page 7-4).

## 8. Upper and Lower Astigmatism

Rotate both FOCUS controls fully clockwise and place both HORIZ. DISPLAY switches at the X10 EXT. ATTEN. position. Position both beams onto the screen, and adjust the Upper Astig. and Lower Astig. controls so that both defocused spots are as nearly circular as possible. Adjust the FOCUS controls so that both spots are in sharp focus. To sharpen the focus further, place both HORIZ. DISPLAY switches at 'A' X1. Set both time-base trigger controls at AC AUTO., +SLOPE, AC COUPLING, and UPPER BEAM SOURCE. Rotate the TIME/CM controls to .5 MILLISEC position. Set the vertical plug-in VOLTS/CM controls at 1, the input selector AC-DC switches at AC, and position both beams to the appropriate horizontal centerlines. Connect a 1-volt signal from the AMPLITUDE CALIBRATOR to both upper and lower beam vertical input connectors. Carefully readjust the Upper Beam FOCUS and Upper Astig. controls for a sharper focus of the leading corner of one square-wave on the upper beam calibrator waveform. Adjust the Lower Beam FOCUS and Lower Astig. controls for the same results on the lower beam calibrator waveform.

## 9. Geometry Adjustments 1 and 2

The geometry of the crt display for both beams is adjusted by means of the Geom. Adj. 1 and the Geom. Adj. 2 con-

trols. To achieve optimum linearity, vertical lines are displayed on the crt and controls are adjusted for minimum curvature of the lines. Nonlinearity is most noticeable at the edges of the graticule.

Place all controls in the positions they were in at the completion of the Upper and Lower Astigmatism adjustments and leave the calibrator signal connected. Rotate the AMPLITUDE CALIBRATOR to the 10-volt position. Increase the intensity of both beams to allow the rising and falling portions of the waveforms to be visible. The tops and bottoms of the square-waves should extend beyond the usable viewing area of the beams. Horizontally align the rising and falling portions of the upper beam waveform with those of the lower beam by using the horizontal positioning controls. Adjust the Geom. Adj. 1 and Geom. Adj. 2 (see Figure 7-5) for straight vertical lines running parallel to the left and right edges of the graticule (see Figure 7-7).

### NOTE

The Type 180 or 180A may be used for this step to provide vertical lines of higher intensity. Use 500  $\mu$ sec markers and position the base line below the viewing area of the beams.

## TIME-BASE TRIGGER CIRCUIT ADJUSTMENTS

The time-base triggering adjustments that follow must be made in the indicated sequence. Controls not mentioned

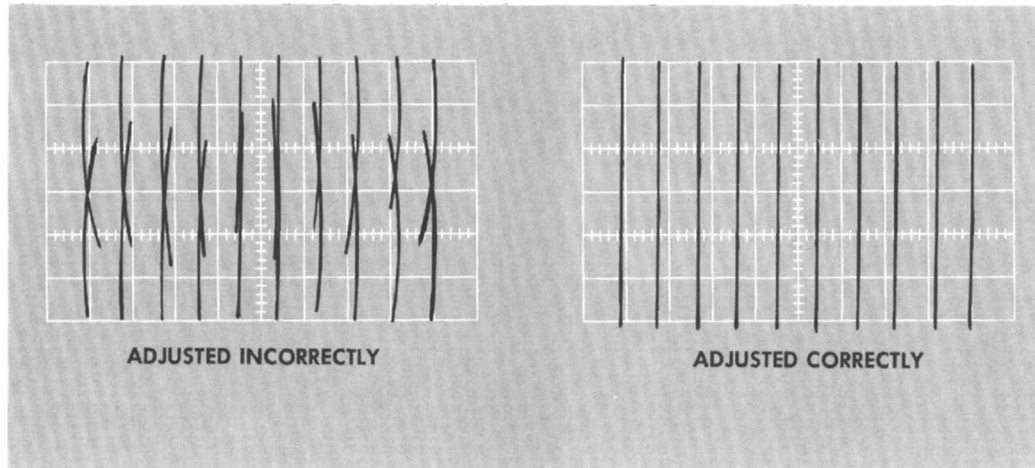

Fig. 7-7. Adjustment of the Geometry controls.

in a particular step are assumed to be in the positions they were last in during the previous step.

Each of the Trigger Circuits is set up in the same manner. Step 10 will tell how to use Time Base B as the test oscilloscope and step 10A will tell about using Time Base A as the test oscilloscope.

**NOTE**

For accessibility to the adjustments it is suggested that the Type 21 be in the TIME BASE A compartment and the Type 22 in the TIME BASE B compartment.

**10. Trigger Level for Time Base A (Type 21)**

Remove the Time Base Unit, attach the Time Base Plug-In Extension and install the unit with the extension in the TIME BASE A compartment of the Type 555.

Set the Upper Beam HORIZ. DISPLAY switch to 'A' X1. Place the 'A' SLOPE switch at +, 'A' COUPLING switch at DC and 'A' SOURCE switch at UPPER BEAM. Rotate the 'A' LEVEL control to zero. Set the lower beam vertical plug-in VOLTS/CM switch at .05 and the input selector AC-DC switch at DC. Place the Lower Beam HORIZ. DISPLAY switch at 'B' X1. Set the 'B' trigger controls at AC AUTO., +SLOPE, AC COUPLING, and LINE SOURCE. Place the 'B' SWEEP FUNCTION switch at NORMAL and the 'B' TIME/CM switch at 2 MILLISEC. Center the lower beam trace at the lower horizontal centerline of the graticule and connect the 10X probe from the lower beam vertical input connector to the junction of R19 and R20 (see Figure 7-8). If the probe is being used with the clip lead ungrounded, position the probe body away from the 'A' SOURCE switch leads to prevent any feedback of signals. Rotate the 'A' LEVEL knob until the lower beam trace is again at the lower horizontal centerline. Loosen the 'A' LEVEL knob and set it at zero position. Tighten the knob and recheck it for exact zero setting and no vertical shift of the lower beam trace by disconnecting and connecting the probe a few times at the junction. Disconnect the probe from the junction.

**10A. Trigger Level for Time Base B (Type 22)**

Remove the Time Base Unit, attach the Time Base Plug-In Extension and install the unit with the extension in the TIME BASE B compartment of the Type 555.

Set the Lower Beam Horiz. DISPLAY switch at 'B' X1. Place the 'B' SLOPE switch at +, 'B' COUPLING switch at DC, and 'B' SOURCE switch at LOWER BEAM. Rotate the 'B' LEVEL control to zero. Set the upper beam vertical plug-in unit VOLTS/CM switch at .05 and the input selector AC-DC switch at DC. Place the Upper Beam HORIZ. DISPLAY switch at 'A' X1. Set the 'A' trigger controls at AC AUTO., +SLOPE, AC COUPLING, and LINE SOURCE. Place the 'A' SWEEP FUNCTION switch at NORMAL and the 'A' TIME/CM switch at 2 MILLISEC. Center the upper beam trace at the upper horizontal centerline of the graticule and connect the 10X probe from the upper beam vertical input connector to the junction of R19 and R20 (see Figure 7-8). If the probe is being used with the clip lead ungrounded, position the probe body away from the 'B' SOURCE switch leads to prevent any feedback of signals. Rotate the 'B' LEVEL knob until the upper beam trace is at the upper horizontal centerline. Loosen the 'B' LEVEL knob and set it at zero position. Tighten the knob and recheck it for exact zero setting and no vertical shift of the upper beam trace by disconnecting and connecting the probe a few times at the junction. Disconnect the probe from the junction.

**11. Upper Beam Internal Trigger DC Level**

Set the TIME/CM switch at .1 MILLISEC, the SOURCE switch at UPPER BEAM and rotate the STABILITY control clockwise for a free-running sweep. Position the trace to the horizontal centerline. Connect a short jumper from the junction of R19 and R20 to the chassis; connect a dc voltmeter from the junction of R22 and SW22 to the chassis (see Figure 7-8). Place the SLOPE switch in the — position and adjust the UPPER BEAM INT. TRIG. DC LEVEL ADJ. control for a voltmeter reading of zero volts. Slide the SLOPE switch from — to + to check for accuracy of the adjustment and no voltmeter needle shift. Leave the SLOPE switch at —.

### 12. Lower Beam Internal Trigger DC Level

Position the lower beam trace to its centerline. Set the SOURCE switch at LOWER BEAM. Adjust the LOWER BEAM INT. TRIG. DC LEVEL ADJ. control for a voltmeter reading of zero volts and no change in meter needle movement when the SOURCE switch is set at UPPER BEAM and back to LOWER BEAM. Disconnect the voltmeter.

### 13. Trigger Level Centering

Rotate the test beam vertical plug-in VOLTS/CM switch to the .5 volts position and set the input selector AC-DC switch at AC. Set the SOURCE switch (of the unit being calibrated) at LINE. Connect the probe to pin 6 of V45 (see Figure 7-8). Preset the TRIG. LEVEL CENT. control so that the waveform on the test beam is symmetrical. For precise adjustment set the test beam's HORIZ. DISPLAY switch at  $\times 2$  and horizontally center the +slope or switching portion of the multivibrator waveform using the test beam's HORIZ. DISPLAY control. Now slide the SLOPE switch up and down from  $-$  to  $+$  and, at the same time, adjust the TRIG. LEVEL CENT. for no horizontal shifting of the switching portion of the waveform. Leave the SLOPE switch at  $+$ .

### 14. Trigger Sensitivity

With the probe and jumper connected as described in the previous step, rotate the TRIG. SENS. control fully counter-

clockwise. Turn the control slowly clockwise and stop at the point where the oscillations cease to appear. Note the amplitude of the spike on the top corner of the multivibrator waveform. Then rotate the TRIG. SENS. control clockwise until this spike is slightly less than one half of the original size (see Figure 7-9). Disconnect the probe from the test point and remove the jumper lead.

### 15. Lockout Level

Set the COUPLING switch at AC, and the SOURCE switch at the proper BEAM. The approximate voltage at pin 7 of V125 is  $-55$  volts. Connect a dc voltmeter at this test point (see Figure 7-8) and rotate the STABILITY control counterclockwise until the sweep just stops free-running. Record the meter reading of the dc voltmeter. Set the SWEEP FUNCTION switch at SINGLE SWEEP and trigger the sweep once by rotating the LEVEL control clockwise to  $+$  and then counterclockwise to  $-$ . If the STABILITY control setting is correct as explained above, the READY lamp should extinguish indicating that the upper beam trace is locked out. Now set the LOCKOUT LEVEL ADJ. control for a voltmeter reading of 11 volts lower (less negative) than the previous reading. To compare voltmeter readings, repeat the procedure given in this step.

### 16. Stability

Set the SWEEP FUNCTION switch at NORMAL. Set the trigger controls at  $+$ SLOPE, LINE SOURCE, and rotate the

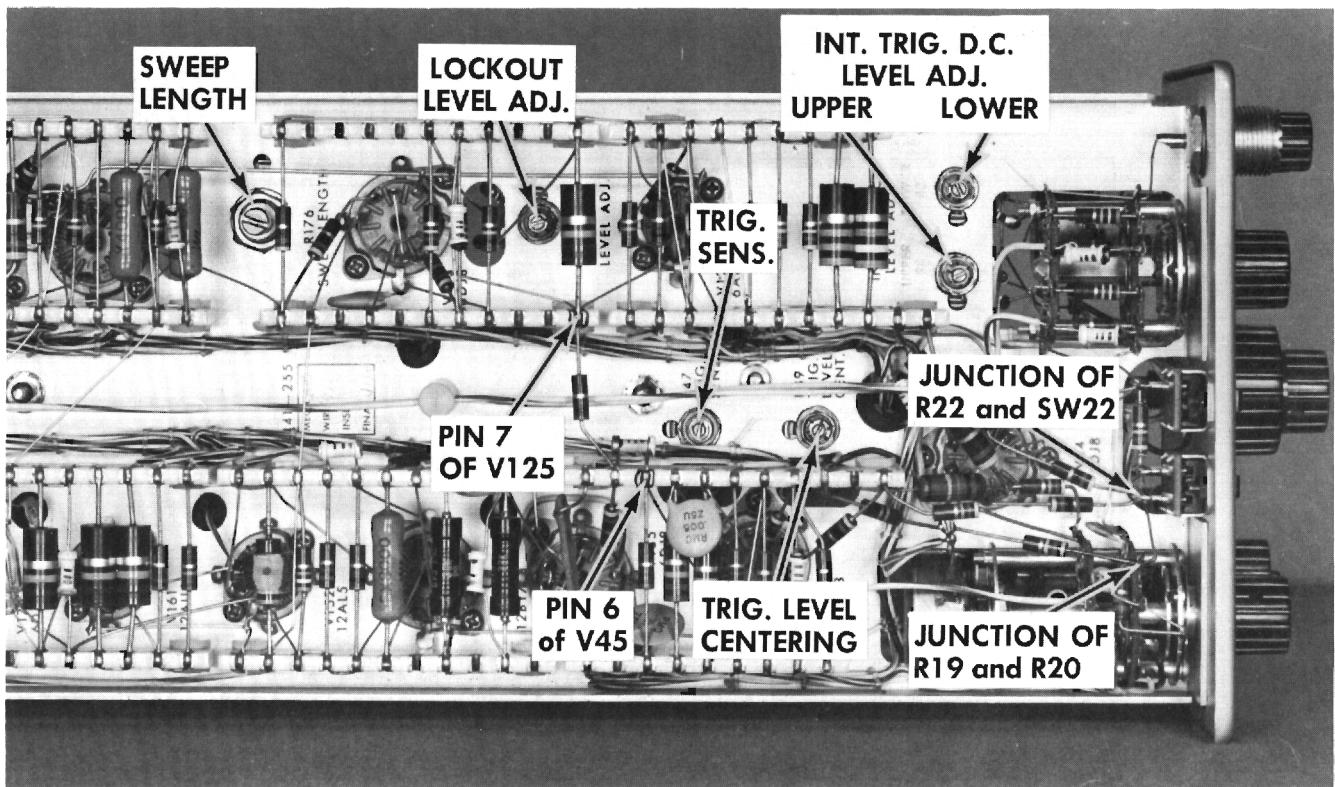

Fig. 7-8. Location of the Type 21 Time-Base Unit calibration controls and test points.

## Calibration Procedure—Type 555

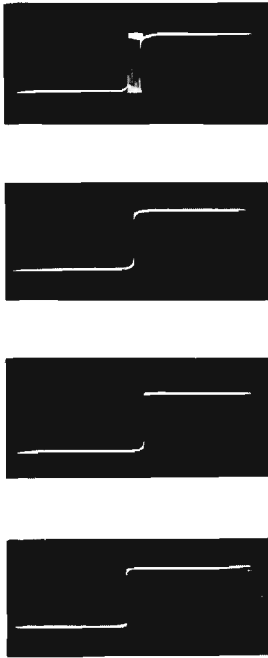

Fig. 7-9. Waveforms 1, 2 and 3 show changes in the waveform as the TRIGGER SENS. control is rotated clockwise. Waveform 4 is the display obtained when the control is adjusted correctly.

LEVEL control fully counterclockwise to the AC AUTO. position. The voltage reading at the junction of the STABILITY wiper arm and R114 is approximately  $-80$  to  $-110$  volts. Connect a dc voltmeter at this junction (see Figure 7-10) and

rotate the 'A' STABILITY control fully counterclockwise. Turn the 'A' STABILITY control until the trace first appears. Record the reading of the dc voltmeter. Then continue to rotate the STABILITY control clockwise until the trace brightens and again record the voltage. Set the STABILITY control for a voltmeter reading midway between the two recorded voltage readings.

### TIMING PROCEDURE FOR TYPE 555 WITH TYPES 21 AND 22 PLUG-INS

In the following steps it is assumed that the Type 21 is in the TIME BASE A compartment, and the Type 22 is in the TIME BASE B compartment.

#### NOTE

The calibration will change slightly when the sides are re-installed.

### 17. Magnifier Gain (R372 and R472)

Set controls as follows:

HORIZ. DISPLAY (Upper and Lower Beam)	TIME BASE A $\times .2$
SLOPE (Type 21)	+
COUPLING (Type 21)	AC
SOURCE (Type 21)	UPPER BEAM
SWEEP FUNCTION (Type 21 and 22)	NORMAL
TIME/CM (Type 21)	1 MILLISEC

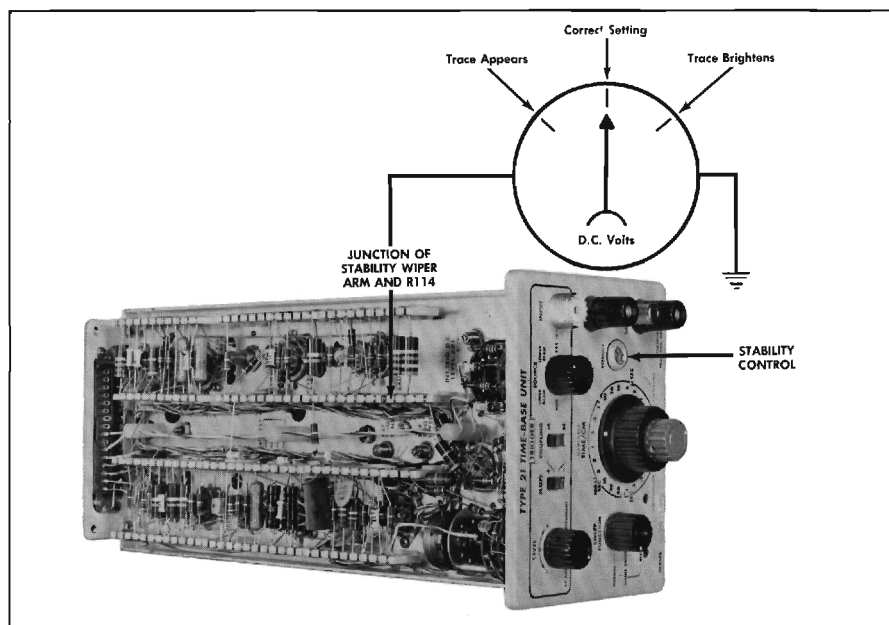

Fig. 7-10. Adjustment of the STABILITY control.

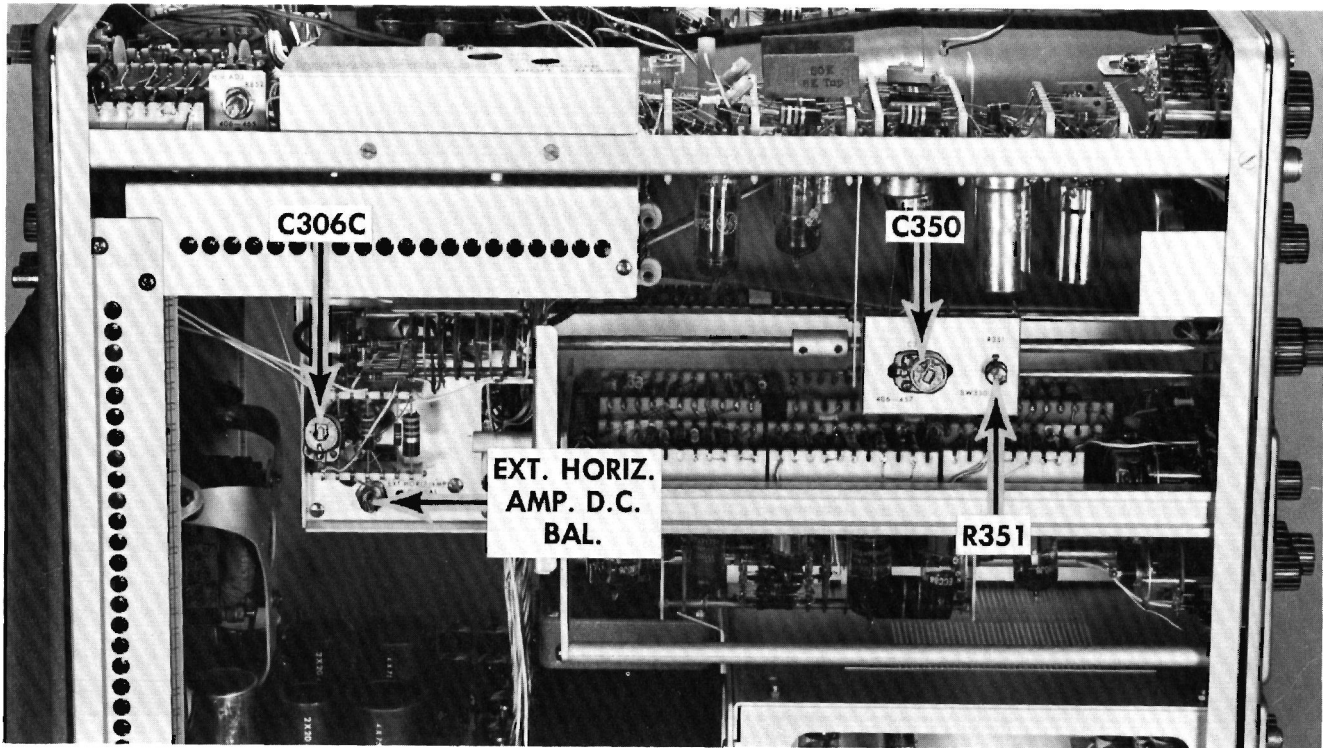

Fig. 7-11. Left side view of indicator unit showing location of upper beam adjustment controls.

Vertical Plug-ins

AC-DC Switch	AC
VOLTS/CM	2 volts
VARIABLE	CALIBRATED

Apply 100 microsecond time markers, from the Time Mark Generator to the vertical inputs of both beams. Adjust the Type 21 level control for a stable display. Now adjust the MAG. GAIN of both A and B Horiz. Amplifiers until a display of two time marks/cm has been obtained.

**18. Sweep Calibration (R351 and R451)**

Set the HORIZ. DISPLAY of both beams of TIME BASE A to  $\times 1$ . Now apply 1 msec time markers and adjust R351 and R451 for one time marker/cm.

**19. Sweep Magnifier Registration (R358 and R458)**

Return the UPPER and LOWER BEAM HORIZ. DISPLAY switches to the TIME BASE A  $\times 2$  position. With 5 nsec markers from the Time-Mark Generator applied, position the middle time marker under the center graticule line. Now set both HORIZ. DISPLAY switches to TIME BASE A  $\times 1$  and adjust R358 and R458 so that the same time marker again falls under the center graticule line.

**20. Sweep Length (Type 21)**

Adjust the sweep length of each TIME BASE UNIT so as to have 10.5 cm of horizontal deflection. This can be easily done if 500 microsec time markers are applied.

**21. Check VARIABLE TIME/CM Control (Type 21)**

The VARIABLE control provides for a complete range of control between the calibrated TIME/CM steps. To check operation of this control, set the Type 21 TIME/CM control to 1 MILLISEC and the VARIABLE to CALIBRATED. Connect 5 MILLISECOND markers from the Type 180A to the vertical inputs and trigger the oscilloscope for a stable display consisting of 1 marker for each 5 cm. Next, turn the VARIABLE control full left. The display should now consist of markers every 2 cm or less. Check to see that the UNCALIBRATED neon indicator lamp lights in all positions of the VARIABLE control except when switched to the CALIBRATED position.

**22. Sweep Length (Type 22)**

Reset the following controls:

HORIZ. DISPLAY (Upper and Lower Beam)	TIME BASE B $\times 1$
	1 MILLISEC
TIME/CM (Type 22)	LOWER BEAM
SOURCE (Type 22)	+
SLOPE (Type 22)	AC
COUPLING (Type 22)	

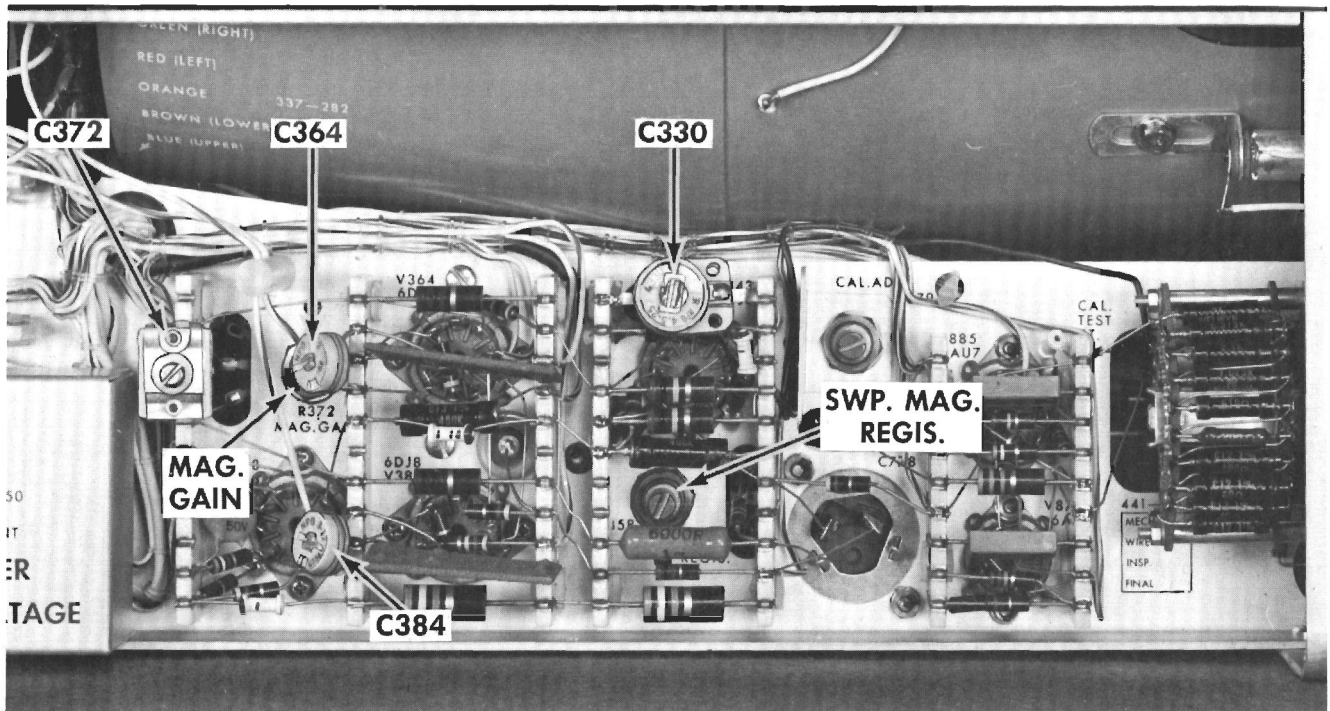

Fig. 7-12. Top view of indicator unit showing the location of upper beam adjustments.

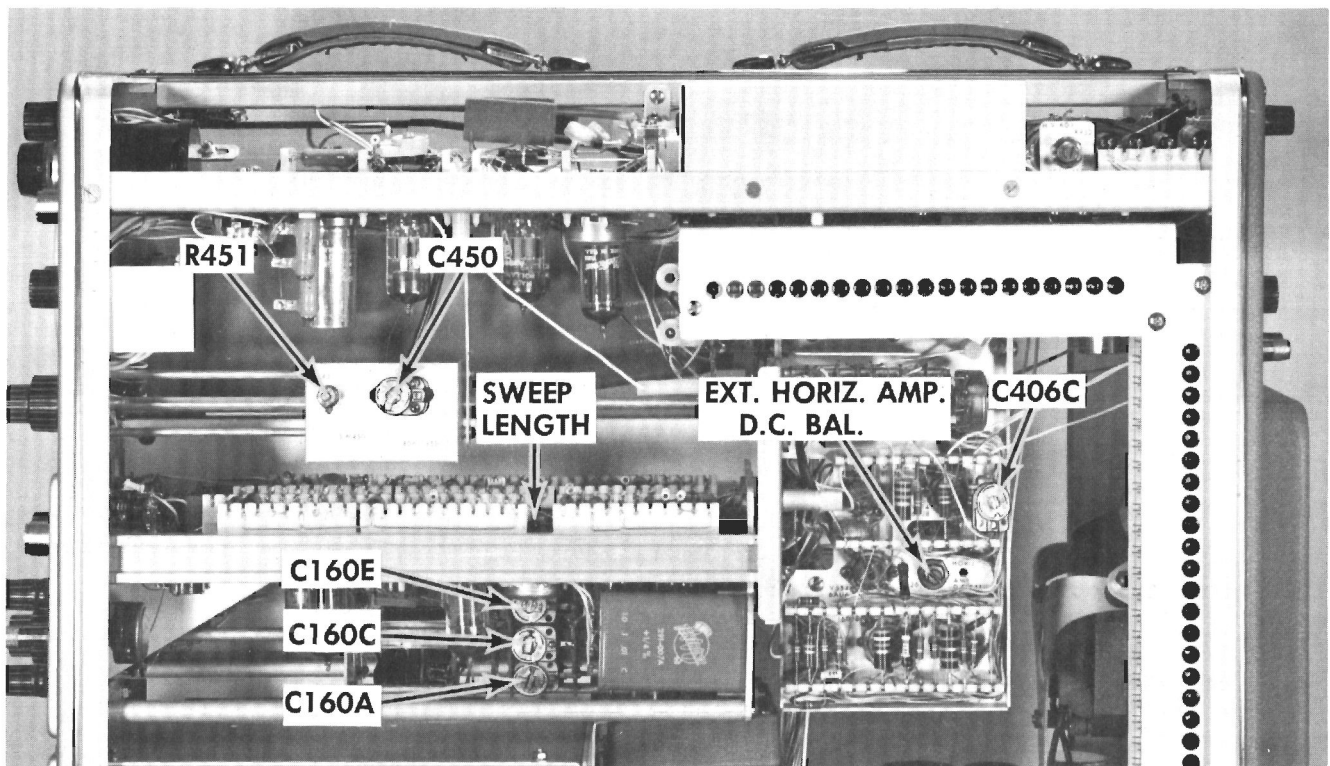

Fig. 7-13. Right side view of indicator unit showing the location of the time base and lower beam adjustments.

The adjustment of this control is the same as stated in step 20.

**NOTE**

The time-base extensions should be removed at this point.

**23. Check VARIABLE TIME/CM Control (Type 22)**

Do this step like step 21.

**24. Check TIME BASE B Sweep Rates (Type 22)**

TIME/CM	TIME-MARK GEN.	OBSERVE
.1 msec	100 $\mu$ sec	1 mark/cm
.2 msec	100 $\mu$ sec	2 mark/cm
.5 msec	500 $\mu$ sec	1 mark/cm
1 msec	1 msec	1 mark/cm
2 msec	1 msec	2 mark/cm
5 msec	5 msec	1 mark/cm
10 msec	10 msec	1 mark/cm
20 msec	10 msec	2 mark/cm
50 msec	50 msec	1 mark/cm
.1 sec	100 msec	1 mark/cm
.2 sec	100 msec	2 mark/cm
.5 sec	500 msec	1 mark/cm
1 sec	1 sec	1 mark/cm
2 sec	1 sec	2 mark/cm
5 sec	5 sec	1 mark/cm

**25. Adjust C330 and C430**

Reset the following controls:

- HORIZ. DISPLAY (Upper and Lower Beam)
- TIME BASE B  $\times .2$
- TIME/CM (Type 22) .1 MILLISEC

Apply 10 microsecond time marks and adjust the LEVEL control in the Type 22 for a stable display. Position the first time marker under the center graticule line. Now adjust **separately** C330 and C430 so that as the TIME/CM switch is moved from .1 millisecc to 50 microsec there is no horizontal movement in the position of the first time marker. Each capacitor will effect a different beam.

**26. High Frequency Timing for both Horizontal Amplifiers and Type 22**

These controls are reset:

- HORIZ. DISPLAY (Upper and Lower Beam)
- TIME BASE B  $\times 1$
- SOURCE (Type 22) EXT.

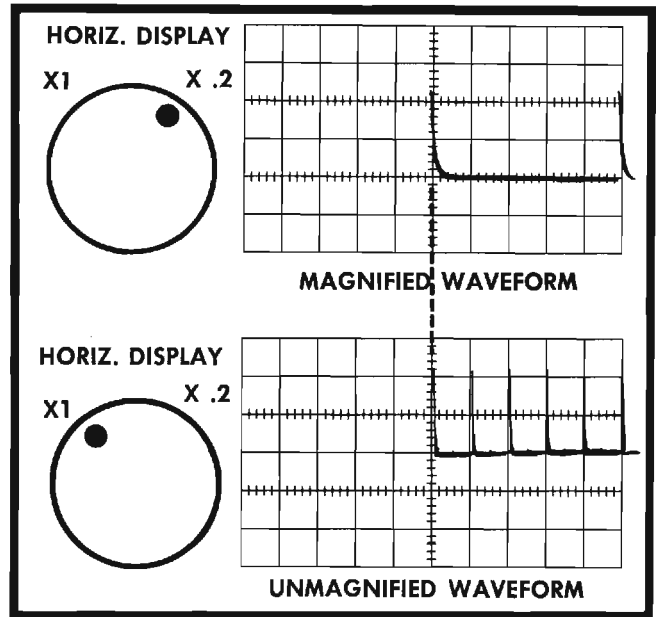

Fig. 7-14. When the adjustment of the SWP. MAG. REGIS. controls are made properly, the portion of the displayed waveform at the exact center of the graticule remains stationary as the appropriate HORIZ. DISPLAY switch is set at the X1 and the X.2 position.

Apply 10 microsecond time markers to the ext INPUT of the Type 22. The adjustments below will interact with each other to some degree, therefore it may be necessary to touch some of the adjustments up a second time.

TIME/CM	TIME-MARK GEN.	LOCA-TION	ADJ.	OBSERVE
(with both HORIZ. DISPLAY switches in B $\times 1$ adjust)				
.5 $\mu$ sec	1 $\mu$ sec		C160A	1 mark/2 cm
.1 $\mu$ sec	10 MC	Horiz. Amp. A	C350	1 cycle/cm
			C372	Linearity
		Horiz. Amp. B	C450	1 cycle/cm
			C472	Linearity
(with both HORIZ. DISPLAY switches in B $\times .2$ adjust)				
.1 $\mu$ sec	50 MC	Horiz. Amp. A	C364	Linearity and timing.
			C384	
		Horiz. Amp. B	C464	Linearity and timing.
			C484	

Reset both the HORIZ. DISPLAY switches to B  $\times 1$  and apply 100 microsecond markers to the ext INPUT of the Type 22. Now make the following adjustments for Type 22:

1 $\mu$ sec	1 $\mu$ sec		C160C	1 mark/cm
2 $\mu$ sec	1 $\mu$ sec			2 mark/cm
5 $\mu$ sec	5 $\mu$ sec			1 mark/cm
10 $\mu$ sec	10 $\mu$ sec		C160E	1 mark/cm
20 $\mu$ sec	10 $\mu$ sec			2 mark/cm
50 $\mu$ sec	50 $\mu$ sec			1 mark/cm

Remove the time marks from the ext. INPUT of the Type 22.

### 27. Delay Start—Stop Adjustments (R576, R572) Type 22

Change the position of the following controls:

HORIZ. DISPLAY (Upper Beam)	TIME BASE A $\times 1$
TIME/CM (Type 21)	1 MILLISEC
TIME/CM (Type 22)	10 MICROSEC
SWEEP FUNCTION (Type 22)	SWEEPS ONCE FOR EACH "A" DEL'D TRIG
SOURCE (Type 21)	UPPER BEAM

Apply 1 millisecond time markers to each of the vertical beams. Trigger the waveforms using the LEVEL control on the Type 21.

With both beams positioned in their proper areas of the graticule, set the 1-10 MULTIPLIER to 1.00. Now adjust the Delay Start so that the small brightened area is on the leading edge of the second UPPER BEAM time marker. The first time marker is that one which occurs at the starting edge (left end) of the trace. When this adjustment is set correctly, you will notice that a magnified presentation of the above mentioned time marker will appear at the start of the LOWER BEAM trace.

Now set the 1-10 MULTIPLIER at 9.00 and adjust the Delay Stop so that the leading edge of the tenth UPPER BEAM marker is brightened. When the adjustment has been set properly the time marker will appear at the start of the LOWER BEAM trace.

The Delay Start and Stop adjustments interact with each other and re-adjustment may be required.

### 28. Adjust H.F. Sweep Rates for TIME BASE A (Type 21)

Re-adjust the TIME/CM controls:

TYPE 21	10 MICROSEC
TYPE 22	.5 MICROSEC

Apply 10 microsecond markers to both Upper and Lower vertical inputs. Adjust the LEVEL control on the Type 21 to obtain stable triggering.

With the 1-10 MULTIPLIER, set the bright portion of the UPPER BEAM trace on the leading edge of the second time marker. Read the 1-10 MULTIPLIER dial and add 8.00 to this reading. Reset the 1-10 MULTIPLIER until the new reading is obtained on the dial. The bright portion of the trace should be near the tenth marker now. Adjust the control (called out below) until the bright portion of the trace rests on the leading edge of the tenth marker. There is considerable interaction in this step and it may have to be repeated several times for each adjustment.

TIME BASE A	TIME BASE B	TIME-MARK GEN.	ADJUST
10 $\mu$ sec/cm	.5 $\mu$ sec/cm	10 $\mu$ sec marker	C160E
20 $\mu$ sec/cm	.5 $\mu$ sec/cm	10 $\mu$ sec marker	Check
50 $\mu$ sec/cm	.5 $\mu$ sec/cm	50 $\mu$ sec marker	Check
1 $\mu$ sec/cm	.1 $\mu$ sec/cm	1 $\mu$ sec marker	C160C
2 $\mu$ sec/cm	.1 $\mu$ sec/cm	1 $\mu$ sec marker	Check
5 $\mu$ sec/cm	.1 $\mu$ sec/cm	5 $\mu$ sec marker	Check

Because of the very fast sweep rate of .1 microsecond, the 1-10 MULTIPLIER can't be used when adjusting C160A. Therefore the following procedure is necessary:

Reset these controls:

HORIZ. DISPLAY (Lower Beam)	TIME BASE A $\times 1$
SOURCE (Type 21)	EXT
SWEEP FUNCTION (Type 22)	NORMAL

This adjustment is done the same as the ones above.

TIME BASE A	TIME-MARK GEN.	ADJ.	OBSERVE
.1 $\mu$ sec/cm	10 mc	C160A	1 cycle/cm
.2 $\mu$ sec/cm	10 mc	Check	2 cycle/cm
.5 $\mu$ sec/cm	1 $\mu$ sec	Check	1 marker/2 cm

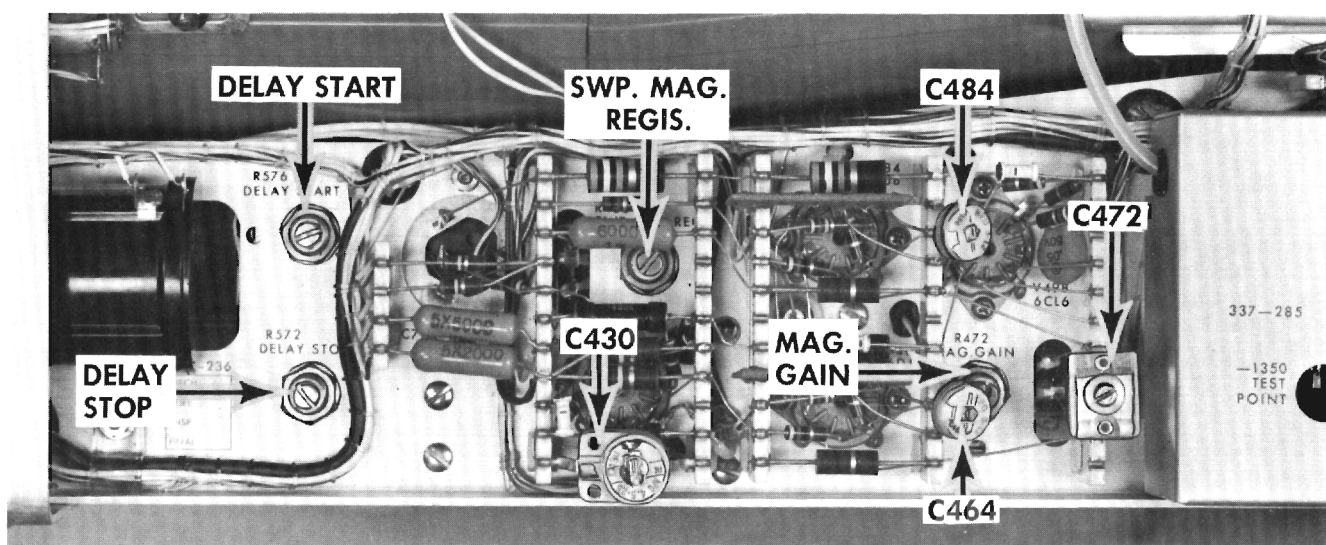

Fig. 7-15. Right top view of indicator unit showing location of lower beam adjustment controls.

Set HORIZ. DISPLAY of both UPPER and LOWER BEAMS to TIME BASE A  $\times 2$ .

.1  $\mu$ sec/cm      50 mc      Check      1 cycle/cm

The following External Horizontal Amplifier adjustments must be done to each of the Time Bases.

**29. External Horizontal Amplifier D.C. Balance**

Place the vertical plug-in VOLTS/CM switch to 20 VOLTS. Connect a jumper from the SAWTOOTH to the vertical INPUT, switch the HORIZ. DISPLAY switch to EXT. ATTEN  $\times 1$  and rotate the LEVEL control full right to the RECURRENT position. Turn the HORIZ. POSITION control to the left to position the vertical trace to the left graticule line. Adjust the Horiz. Amp. D.C. Bal. control (see Figure 7-11) for no horizontal shift of the trace while rotating the EXT. HORIZ. GAIN control.

**30. Check EXT. HORIZ. INPUT Deflection Factor**

With control settings as in Step 29, connect a jumper from the CAL. OUT to the Upper Beam EXT. HORIZ. INPUT connector. Set the AMPLITUDE CALIBRATOR at .2 VOLTS and turn the EXT. HORIZ. GAIN control full right. At least one centimeter of horizontal deflection must be displayed. Increase the AMPLITUDE CALIBRATOR to 2 volts and adjust the EXT. HORIZ. GAIN control for exactly 10 cm of horizontal deflection. Place the HORIZ. DISPLAY switch at EXT. ATTEN.

$\times 10$ . The horizontal deflection should now be one centimeter. (Attenuator accuracy  $\pm 3\%$ ).

**31. External Horizontal Input Compensation**

With the jumpers connected as in Steps 29 and 30, set the AMPLITUDE CALIBRATOR at .5 VOLTS. Connect a third jumper from the CAL. OUT to the trigger INPUT connector. Set the Time-Base controls as follows:

HORIZ. DISPLAY	EXT. ATTEN. $\times 1$
SLOPE	—
SOURCE	EXT.
FUNCTION	NORMAL
TIME/CM	1 MILLISEC

Adjust the LEVEL control for a stable square-wave, displayed vertically. Adjust C330 or C430 (See Figure 7-12) for optimum square-wave response. Place the HORIZ. DISPLAY switch at EXT. ATTEN.  $\times 10$ , increase the AMPLITUDE CALIBRATOR signal to 5 VOLTS and adjust C306C (see Figure 7-11) for optimum flat top. Disconnect all the jumper leads.

**LOWER AND UPPER BEAM VERTICAL AMPLIFIER ADJUSTMENTS**

The vertical adjustments for both vertical amplifiers are done in the same manner. You may use either Time-Base Generator in these adjustments.

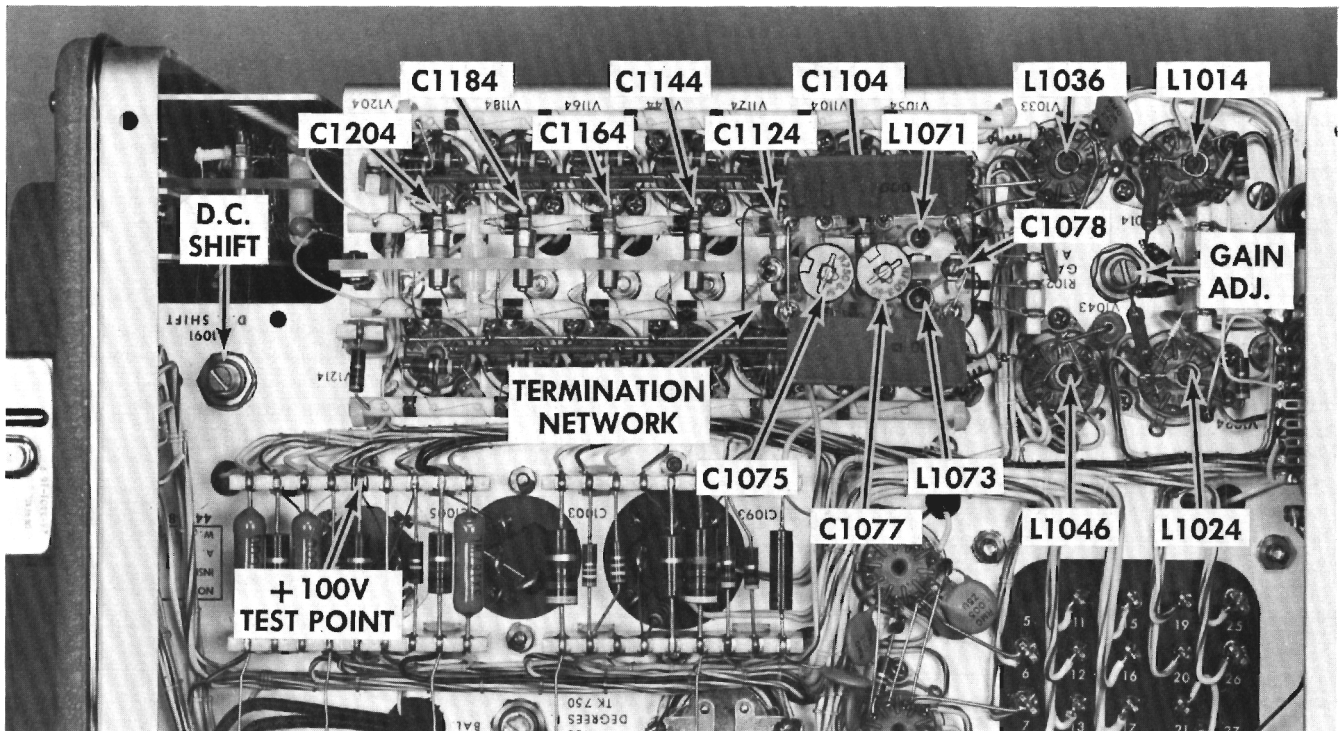

Fig. 7-16. Bottom view of indicator unit showing the location of the upper beam vertical amplifier adjustments and the +100 V test point. C1104 and C1124 are located below the termination network.

### 32. Gain Adjust

Connect the EP53A Gain Set Adaptor between the vertical plug-in connector and the plug-in unit. Connect a jumper from the CAL. OUT connector to the connector on the gain set adaptor. Place the AMPLITUDE CALIBRATOR switch in the .2 VOLTS position and adjust the oscillator for a stable display. Lay the indicator unit on its side and set the GAIN ADJ. control (see Figure 7-16) for exactly 2 centimeters of vertical deflection. Remove the jumper lead and adaptor. Re-install the plug-in.

### 33. Vertical D.C. Shift Compensation

Place the TIME/CM switch at 2 SEC. Rotate the LEVEL control full right to the RECURRENT position and set the vertical input AC-DC selector switch at DC. Intermittently apply the probe to the +100 V test point (see Figure 7-16), or other regulated dc supply, and set the vertical sensitivity to obtain about 3 cm deflection. Look for a slow rise or a slow fall of the beam with a time constant of one or two seconds. If necessary, adjust the D.C. SHIFT control until the spot comes immediately to the final level without drifting either up or down after each time the probe is applied. Disconnect the probe at both ends and turn the indicator unit upright.

### 34. Adjust Delay Line and High-Frequency Compensation

Delay line adjustments are probably the most difficult adjustments to make. This is due to interaction between the large number of controls. The adjustments can be made properly with a minimum of difficulty if the proper procedure is followed and if care is used in making the adjustments. In general, it is not necessary to completely re-adjust the delay line, but occasionally touch up the line for best results. Before attempting to adjust the line, briefly run through this procedure to establish the basic concepts in your mind. This will make the actual adjustments considerably easier. Be sure that the circuits are operating normally and the line requires adjustment before attempting to adjust it.

In general, the procedure for adjusting the delay line and high frequency control involves application of a fast rising pulse or square wave to the vertical amplifier. The delay line is then adjusted for minimum distortion of the pulse or square wave displayed on the screen. In particular, the delay line and amplifier high frequency controls are adjusted for three characteristics of the displayed waveform: fastest possible risetime without overshoot, minimum irregularities on the top of the pulse, and minimum slope of the top of the waveform.

### 35. Displaying the Test Signal

To determine the extent of misadjustment of the delay line you will need to closely examine a displayed fast rising pulse or square wave. The waveform used to make this examination should have a risetime of no

more than 4 nanoseconds. A Tektronix Type 107 Square-Wave Generator or a Tektronix Type P Plug-In Unit is recommended.

If a Type 107 Square-Wave Generator is used, the frequency control should be set to obtain approximately 400 kc square waves. The output of the generator should be connected through a 52-ohm coaxial cable and termination resistor, to the input of either a Type K or a Type L Plug-In Unit. The termination resistor should be connected at the input to the plug-in unit. The plug-in unit must be known to be correctly compensated for high-frequencies before checking or adjusting the delay line.

When a Type P Plug-In Unit is used, it is only necessary to insert the unit into the plug-in compartment of the oscilloscope. The pulse frequency of the P Unit is fixed.

If it is necessary to use a signal generator other than a Type 107 or Type P, you must check the output waveform from the generator for suitability. A waveform which is distorted in any manner is not suitable for adjusting the delay line of an oscilloscope. A good check on the suitability of your test equipment is to display the output waveform on the other beam if the delay line and the vertical plug-in unit are known to be correctly adjusted (see Figures 7-17 and 7-23).

When the input signal has been connected, adjust the oscilloscope triggering controls for a stable display. Rotate the TIME/CM control to .1  $\mu$ SEC and adjust the oscilloscope and signal source for approximately 2 to 3 centimeters of vertical deflection.

With the oscilloscope display, it is possible to check the delay line and amplifier adjustments for proper setting. There are three general characteristics which you will have to appraise, and to do this, you will need to use three different sweep rates. The first characteristics to look for is the level of the display; the second is the amount of bumpiness contained in the flat top of the displayed waveform; and the third is the risetime of the displayed waveform.

### Determining the Level of the Display

The level of the display refers to the top of the displayed waveform. The waveform should show neither an upward nor a downward slope or level anywhere along the early part of the top of the waveform (see Figure 7-18). Any slope of the waveform can most easily be seen with a sweep rate of approximately 5  $\mu$ seconds per centimeter.

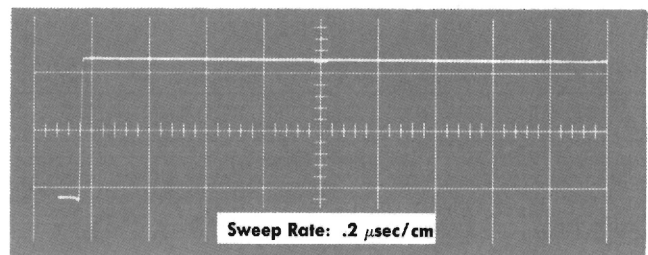

Fig. 7-17. Appearance of the display when the delay line and high frequency compensations are properly adjusted.

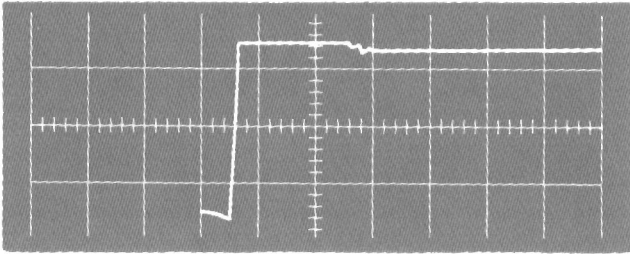

Fig. 7-18. Illustrating an upward level of early part of waveform. Complete readjustment is necessary. Sweep rate: .2  $\mu$ SEC.

### Checking the Bumpiness of the Display

The next characteristic to look for in the displayed waveform is the bumpiness in the top portion of the waveform immediately following the rise. This is the portion of the waveform affected by the delay line adjustments. To make this observation; use a sweep rate of approximately .2  $\mu$ seconds per centimeter.

There are two general types of bumps to be found in a poorly adjusted delay line. The first type is the irregularity caused by the misadjustment of a group of capacitors. This type is indicated by a fairly long duration bump (see Figure 7-19). If the bumps occur at random intervals along the de-

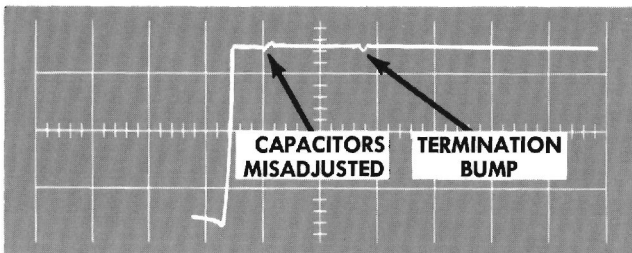

Fig. 7-19. Illustrating irregularity caused by a group of misadjusted capacitors. The termination bump is caused by faulty adjustment in the termination network.

lay line, they are probably due to misadjustment of the delay line and can usually be corrected by a few slight adjustments. However, if there is a certain rhythmic waviness of symmetry to their appearance, the trouble may be due to a faulty adjustment in the terminating network. The trouble could also be an improper adjustment of the amplifier high frequency compensation. In either case a complete adjustment may be necessary (see Figure 7-20).

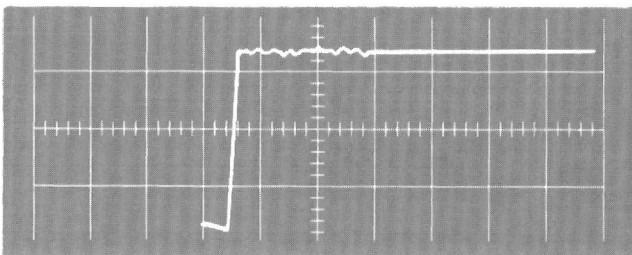

Fig. 7-20. Illustrating severe waviness where complete readjustment is necessary.

The second kind of bump is caused by misadjustment of a single delay line capacitor. This is indicated by a very short duration bump. This type can easily be corrected by readjustment of the misadjusted capacitor. The proper capacitor can be determined by observing the location of the bump on the displayed waveform.

### Checking the Rise of the Displayed Waveform

The third characteristic to be investigated in the displayed waveform is the extreme leading edge and corner. This part of the waveform is affected by the vertical amplifier high frequency peaking coils and the delay line adjustments closest to the cathode-ray tube neck connections. These adjustments collectively determine the high frequency response of the vertical deflection system and for that reason are of the utmost importance.

The leading edge of the displayed waveform is best observed with a sweep rate of approximately .1  $\mu$ second per centimeter. The corner should be as sharp as possible with no overshoot, as shown in Figure 7-17. An example of overshoot caused by maladjusted inductors is illustrated in Figure 7-21. While it is necessary that the corner be as sharp as possible for optimum frequency response, it is also necessary that there be no wrinkles or bumpiness in this portion of the display.

There is a good deal of similarity in the effect of the amplifier peaking coils and the delay line adjustments. For this reason, it is sometimes difficult to ascertain which adjustments are faulty. The adjustments at fault can usually be determined by the location and occurrence of the waveform irregularities.

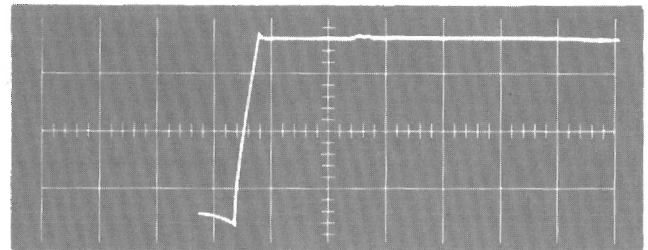

Fig. 7-21. Overshoot caused by maladjusted inductors.

#### NOTE

In the procedure that follows, the trimmer capacitors in the Type 555 Oscilloscope vertical amplifier are considered to be part of the delay line. They are adjusted in the same manner as other delay line capacitors.

## 36. Physical Presetting

Perhaps the most important single bit of information you should know is to observe the approximate positions of the various adjustments in a properly adjusted delay line. Since the Type 555 Oscilloscope has two delay lines, one delay line can be checked against the other. This knowledge can

## Calibration Procedure—Type 555

be used as a good starting off point. And later, during the adjustment procedure, comparisons can be made as a check on your progress.

The variable inductors in the vertical amplifier (see Figure 7-16) and at the neck connections (see Figure 7-22) to the crt are normally preset so that the slugs are just out of the coil windings. They can be set by shining a light through the coil forms and adjusting the slugs. By presetting the slugs in this manner you will reduce the effects of the inductors during the delay line adjustment procedure. Then, during the last step of the adjustment procedure, you will move the slugs into the coils (usually about two or three turns).

If in your preliminary investigation, you detected a cyclic waviness in the display, or if there was extreme overshoot at the leading edge, you will probably save yourself considerable time by presetting the variable inductors. Usually, turning the slugs too far out of the coil will only result in a rounding off of the leading edge. However, turning the slugs too far into the coil winding will result in severe wrinkles in the displayed waveform—wrinkles which can frequently be reduced by misadjusting the delay line. This must give you the impression that the delay line was at fault instead of the high frequency peaking coils.

The variable capacitors in the delay line will not, as a rule, require presetting. If the performance of the instrument has deteriorated as a result of normal use and handling, the delay line should require only touching up. The

original physical positions of the capacitors should be very nearly correct. On the other hand, if the instrument has been tampered with, or if it has been subject to severe vibration or rough handling, it may be desirable to preset the delay line capacitors as described in the following paragraph.

In a properly adjusted delay line, the adjusting screw extends above the capacitor body  $\frac{3}{8}$  inch. The important characteristic is that the tops of all the delay line adjusting screws should be about the same height. It is very important to keep this characteristic in mind as you adjust the delay line. Normally, trimmers located at points where fixed capacitors are connected across the delay line are somewhat higher than other trimmer capacitors.

If you can observe a waviness in the height of the adjusting screws (while at the same time, the display is level), the trouble is probably due to misadjustment of the inductors in the vertical amplifier. In this event, you should recheck the physical positions of the slugs as described in the previous paragraphs.

If, in the preliminary inspection, you notice a bump following the termination bump (that is, on the portion of the delay line not normally affected by delay adjustments), be sure to check the termination inductors for balance. The slugs in both inductors should be equidistant from the coil windings. When you adjust the slugs, be sure to adjust each slug the same amount.

As a final step in the physical presetting procedure, dress the leads to the crt vertical-deflection plates. They are to

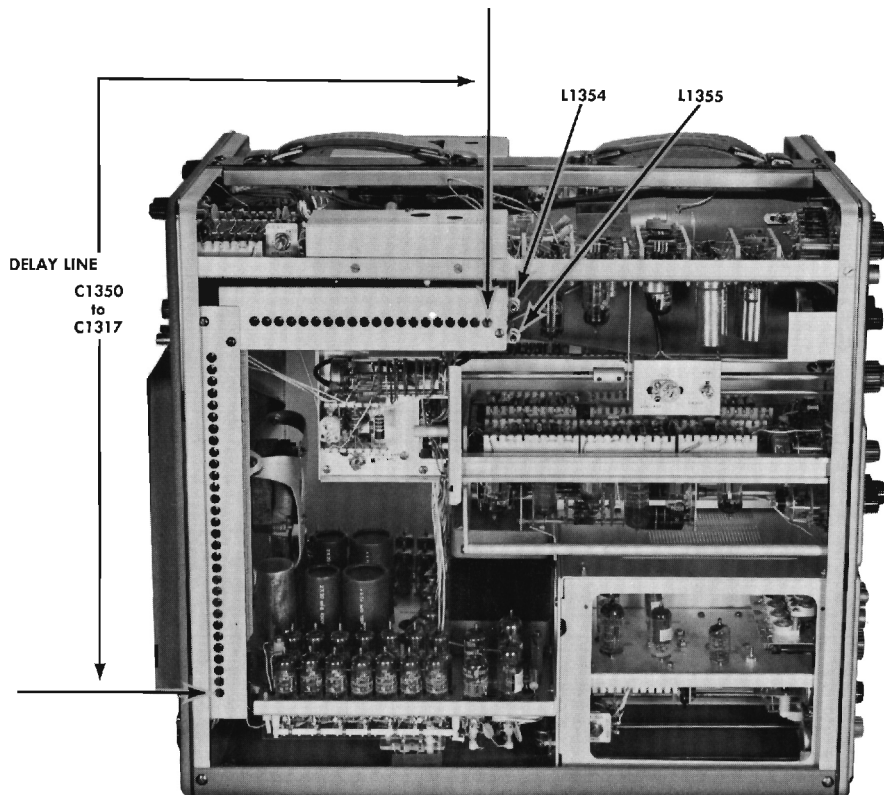

Fig. 7-22. Left side view of indicator unit showing the location of the upper beam delay line and indicator adjustments.

be uniformly spaced, both with respect to each other and with respect to the crt shield.

### 37. Establishing a Level Display

The level of the flat top of the displayed waveform is determined by the collective effect of all the delay line capacitors. When the delay line is properly adjusted, the top of the displayed waveform should be almost perfectly flat.

To make the display level, adjust each delay line capacitor a small amount in a direction that will result in a level display. Start at the termination network by adjusting the amplitude. Then, advance from capacitor to capacitor on the delay line, working toward the crt end. During your first attempt, you will probably find it most convenient to use a sweep rate of approximately  $5 \mu\text{seconds}$  per centimeter. After you have adjusted all of the capacitors to gain an average level over the length of the flat top of the displayed waveform, you can advance the sweep rate to  $2 \mu\text{seconds}$  per centimeter and repeat the procedure. This time, however, try to adjust the capacitors for a smooth transition from bump to bump, while at the same time maintaining a satisfactory level. The important thing to remember is to reduce the amplitude of all of the bumps by the same amount and not try to achieve a perfectly straight line at this time.

### 38. Removing the Bumps and Wrinkles

After you have established a level display with the amplitude of the bumps and wrinkles reduced to within a trace width of the level line, you can start to remove the wrinkles and bumps over smaller sections of the display. It is usually best to start at the terminated end of the delay line and work toward the crt end.

Set the TIME/CM switch at  $.5 \mu\text{SEC}$  and proceed to remove the bumps caused by the termination network. Do not try to arrive at a perfectly straight line during your first attempt. Just reduce the bumps by one-half. Then, advance to the first group of 4 or 5 capacitors in the delay line and adjust them for a smooth line over the portion of the display that they affect. Keep in mind that each capacitor will only require a slight adjustment—a mere "touch"—and that it is the combined effect of the group of capacitors that you should be concerned with.

While you are adjusting a group of capacitors to remove a bump or wrinkle, be sure to frequently turn to a sweep rate of 2 or 5 microseconds/centimeter and check the level of the display.

Advance along the delay line from each group of capacitors to the next until you have traversed the entire length. Then, turn the TIME/CM switch to  $.2 \mu\text{SEC}$  and repeat the process. This time, however, you must be extra careful. The capacitors that require adjustment will only need a slight touch—to do otherwise might nullify all your efforts up to this point. Be sure to check the level of the display frequently. It is very easy to concentrate on removing a particularly stubborn bump and, in so doing, introduce an upward or downward slope in the display.

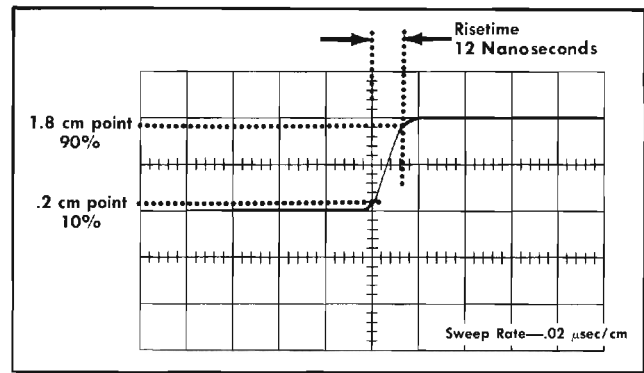

Fig. 7-23. Measurement of vertical risetime.

At this point in the adjustment procedure, it will not be necessary to adjust every capacitor. Touching up here and there will probably produce the desired results.

### 39. Adjusting the High Frequency Compensation

If you have successfully completed the adjustment procedure up to this point, the display should be level and free of bumps and wrinkles with a pronounced rolloff on the leading edge. During this final part of the adjustment procedure, you will strive for a square corner on the leading edge, while at the same time maintaining the proper level without introducing wrinkles or bumps.

Set the TIME/CM switch at  $.2 \mu\text{SEC}$  and position the display to afford a good view of the leading edge and corner. The inductors in the vertical amplifier and near the crt affect this portion of the waveform. The delay line capacitors nearest the crt also affect the leading edge of the waveform. It is important that you adjust each pair of inductors in conjunction with each other. Each inductor should be set at the same position as its corresponding-opposite inductor.

Adjust the inductors, in pairs, for the squarest possible corner. It may be necessary to readjust the first two or three capacitors closest to the crt in order to achieve a wrinkle-free corner.

At this time the displayed waveform should be level on top, there should be virtually no bumps or wrinkles, and the risetime of the displayed waveform should be within specifications for the instrument. A risetime check on the displayed waveform gives a very good check on the completeness of the adjustments.

### 40. Check Risetime

Display the fast rise pulse or square wave as described in Step 39. Place the HORIZ. DISPLAY switch at  $\times 2$ . Adjust the oscilloscope and signal source for exactly 2 centimeters of vertical deflection. Under these conditions the time for the pulse to rise from 0.2 to 1.8 centimeters should be 12 nanoseconds (see Figure 7-23). This can be checked using the HORIZ. POSITION control.

Using the HORIZ. POSITION control to position the display so that the center vertical line of the graticule passes through the rising portion of the waveform 0.2 centimeters

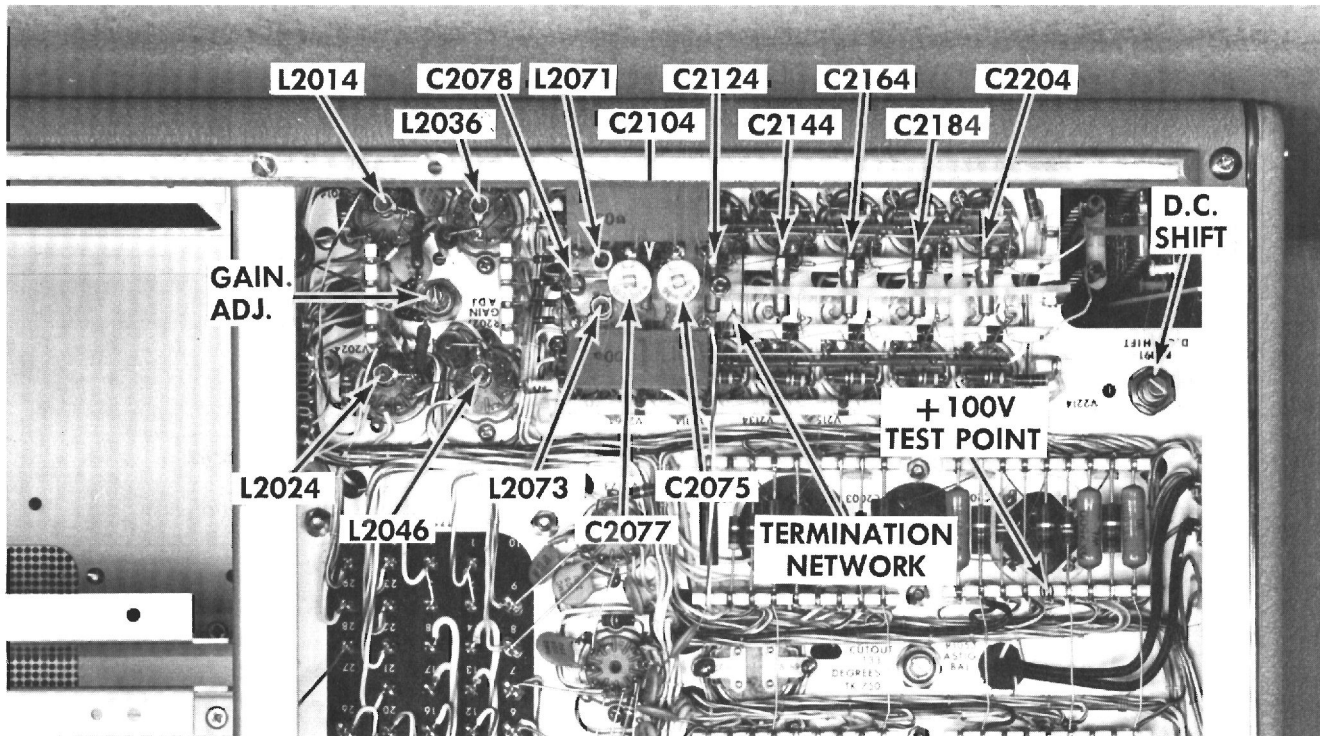

Fig. 7-24. Bottom view of indicator unit showing the location of the lower beam vertical amplifier adjustments and +100 V test point. C2104 and C2124 are located below the termination network.

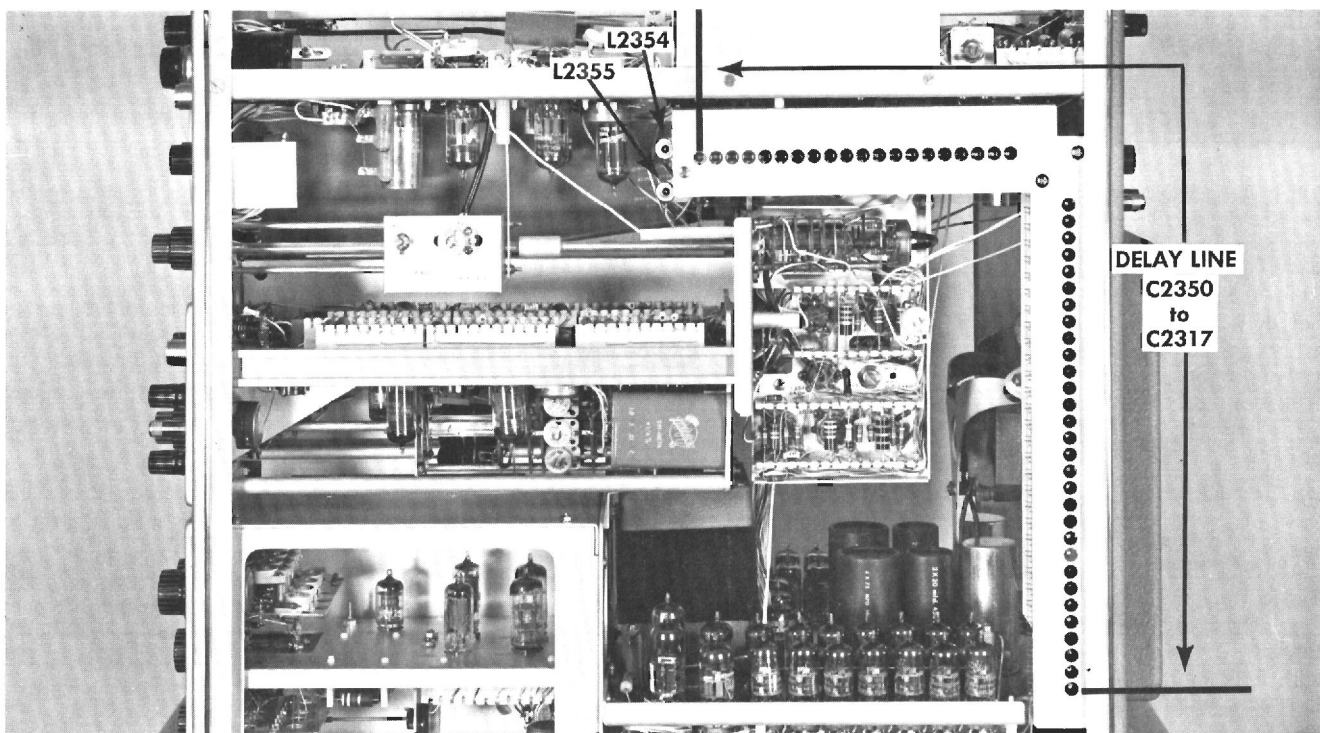

Fig. 7-25. Right side view of indicator unit showing location of lower beam delay line and inductor adjustments.

from the bottom of the rise. Measure the horizontal distance between the 0.2 and 1.8 centimeter point shown in Figure 7-23. Multiply the distance measured by the setting of the TIME/CM control and then the product is multiplied by 0.2 to obtain the actual risetime interval. Disconnect the pulser or square-wave generator.

#### 41. Check Vertical Amplifier Bandwidth

A good check on the completeness of your adjustments to the delay line and vertical amplifier is to measure the

bandwidth of the vertical-deflection system. To make this check, connect the output of the Type 190A through a 50-ohm Terminating Resistor to the vertical input connector. Rotate the trigger LEVEL control fully clockwise to the RECURRENT position. Set the TIME/CM switch at 1 MILLISEC. Place the vertical VOLTS/CM switch at .05 VOLTS. Adjust the output of the Type 190A to obtain a display of 2 mc sine waves at an amplitude of 4 cm peak-to-peak. Increase the frequency while maintaining the peak-to-peak volts reading constant on the Type 190A front-panel meter until the deflection decreases to 2.8 cm peak-to-peak on the oscilloscope display. Determine the oscillator frequency at this point. It should be 30 mc or higher.

# PARTS LIST *and* DIAGRAMS

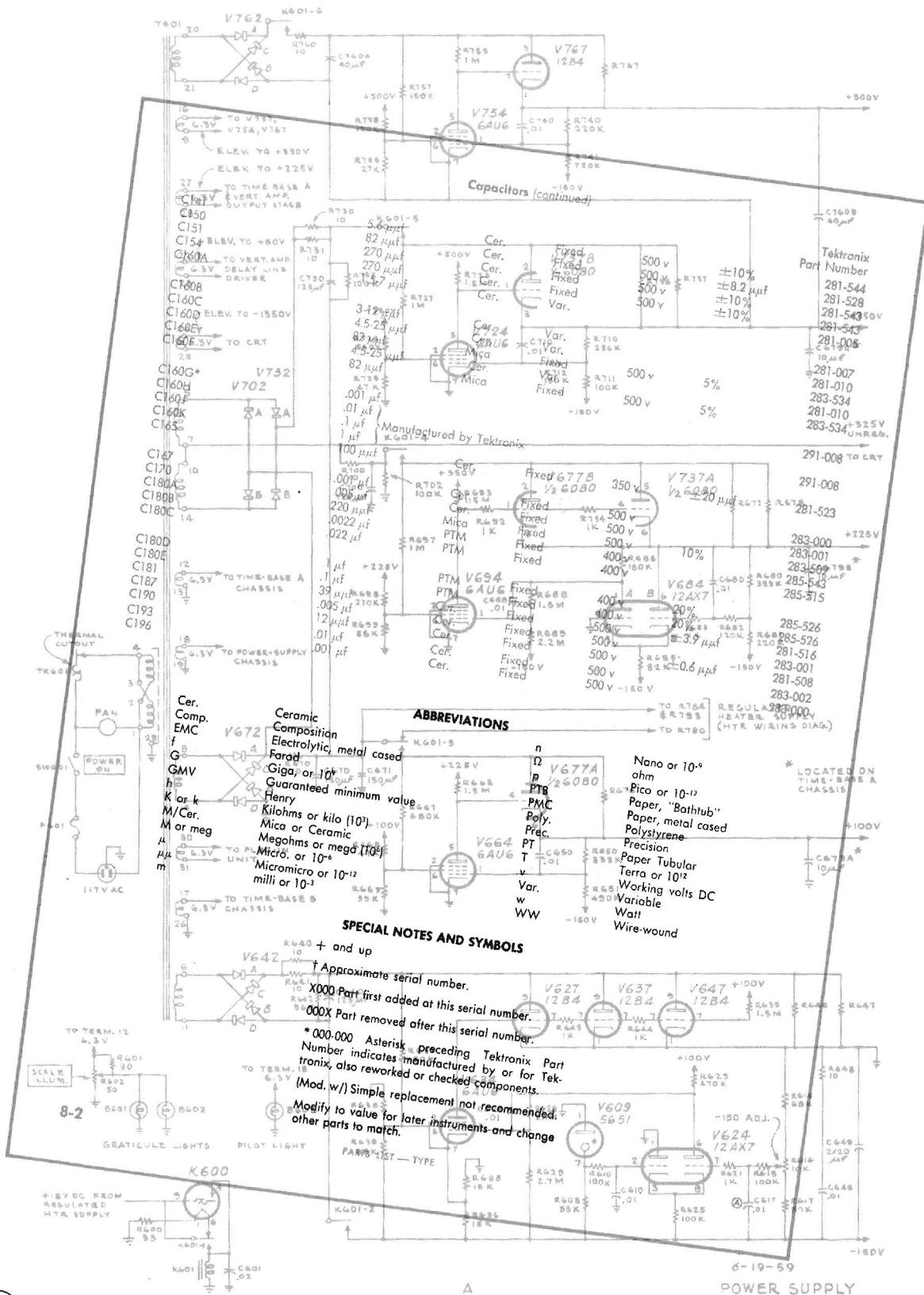

MANUFACTURERS OF CATHODE-RAY OSCILLOSCOPES

## **HOW TO ORDER PARTS**

Replacement parts are available through your local Tektronix Field Office.

Improvements in Tektronix instruments are incorporated as soon as available. Therefore, when ordering a replacement part it is important to supply the part number including any suffix, instrument type, serial number, plus a modification number where applicable.

If the part you have ordered has been improved or replaced, your local Field Office will contact you if there is a change in part number.

## TYPE 555

### Bulbs

			Part Number
			Tektronix
B364	X1320-up	Neon, Type NE-2	150-002
B384	X1320-up	Neon, Type NE-2	150-002
B395		Neon, Type NE-2	150-002
B396		Neon, Type NE-2	150-002
B464	X1320-up	Neon, Type NE-2	150-002
B484	X1320-up	Neon, Type NE-2	150-002
B495		Neon, Type NE-2	150-002
B496		Neon, Type NE-2	150-002
B601		Incandescent, #47	150-001
B602		Incandescent, #47	150-001
B603		Incandescent, #47	150-001
B1083		Neon, Type NE-2	150-002
B1227		Neon, Type NE-2	150-002
B2083		Neon, Type NE-2	150-002
B2227		Neon, Type NE-2	150-002

### Capacitors

C306C		7-45 $\mu\mu\text{f}$	Cer.	Var.			281-012
C306E		330 $\mu\mu\text{f}$	Cer.	Fixed	500 v	$\pm 10\%$	281-546
C322		.005 $\mu\text{f}$	Cer.	Fixed	500 v		283-001
C330		4.5-25 $\mu\mu\text{f}$	Cer.	Var.			281-010
C340		4.7 $\mu\mu\text{f}$	Cer.	Fixed	500 v	$\pm 1 \mu\mu\text{f}$	281-501
C350		1.5-7 $\mu\mu\text{f}$	Cer.	Var.			281-005
C355		1.5 $\mu\mu\text{f}$	Cer.	Fixed	500 v	$\pm 0.5 \mu\mu\text{f}$	281-526
C364	101-569	3-12 $\mu\mu\text{f}$	Cer.	Var.			281-036
C364	570-up	5-25 $\mu\mu\text{f}$	Cer.	Var.			281-011
C372		9-180 $\mu\mu\text{f}$	Mica	Var.			281-023
C380		6.25 $\mu\text{f}$	EMT	Fixed	300 v		290-000
C384	101-569	3-12 $\mu\mu\text{f}$	Cer.	Var.			281-036
C384	570-up	5-25 $\mu\mu\text{f}$	Cer.	Var.			281-011
C390		.05 $\mu\text{f}$	Cer.	Fixed	50 v		283-010
C392		4.7 $\mu\mu\text{f}$	Cer.	Fixed	500 v	$\pm 1 \mu\mu\text{f}$	281-501
C394	X420-up	.005 $\mu\text{f}$	Cer.	Fixed	500 v		283-001
C406C		7-45 $\mu\mu\text{f}$	Cer.	Var.			281-012
C406E		330 $\mu\mu\text{f}$	Cer.	Fixed	500 v	$\pm 10\%$	281-546
C422		.005 $\mu\text{f}$	Cer.	Fixed	500 v		283-001
C430		4.5-25 $\mu\mu\text{f}$	Cer.	Var.			281-010
C440		4.7 $\mu\mu\text{f}$	Cer.	Fixed	500 v	$\pm 1 \mu\mu\text{f}$	281-501
C450		1.5-7 $\mu\mu\text{f}$	Cer.	Var.			281-005
C455		1.5 $\mu\mu\text{f}$	Cer.	Fixed	500 v	$\pm 0.5 \mu\mu\text{f}$	281-526
C464	101-569	3-12 $\mu\mu\text{f}$	Cer.	Var.			281-036
C464	570-up	5-25 $\mu\mu\text{f}$	Cer.	Var.			281-011
C472		9-180 $\mu\mu\text{f}$	Mica	Var.			281-023
C480		6.25 $\mu\text{f}$	EMT	Fixed	300 v		290-000
C484	101-569	3-12 $\mu\mu\text{f}$	Cer.	Var.			281-036
C484	570-up	5-25 $\mu\mu\text{f}$	Cer.	Var.			281-011
C490		.05 $\mu\text{f}$	Cer.	Fixed	50 v		283-010
C492		4.7 $\mu\mu\text{f}$	Cer.	Fixed	500 v	$\pm 1 \mu\mu\text{f}$	281-501
C494	X420-up	.005 $\mu\text{f}$	Cer.	Fixed	500 v		283-001
C512		.02 $\mu\text{f}$	Cer.	Fixed	600 v		283-006
C520		.005 $\mu\text{f}$	Cer.	Fixed	500 v		283-001
C523		12 $\mu\mu\text{f}$	Cer.	Fixed	500 v	$\pm 1.2 \mu\mu\text{f}$	281-506
C530		.005 $\mu\text{f}$	Cer.	Fixed	500 v		283-001
C533		12 $\mu\mu\text{f}$	Cer.	Fixed	500 v	$\pm 1.2 \mu\mu\text{f}$	281-506
C561		.01 $\mu\text{f}$	Cer.	Fixed	500 v		283-002
C565		.005 $\mu\text{f}$	Cer.	Fixed	500 v		283-001
C584		27 $\mu\mu\text{f}$	Cer.	Fixed	500 v	$\pm 5.4 \mu\mu\text{f}$	281-513
C594		47 $\mu\mu\text{f}$	Cer.	Fixed	500 v	$\pm 9.4 \mu\mu\text{f}$	281-518

Capacitors (continued)

						Tektronix Part Number
C597		.005 $\mu$ f	Cer.	Fixed	500 v	283-001
C601		.02 $\mu$ f	Cer.	Fixed	150 v	283-004
C610		.01 $\mu$ f	PTM	Fixed	400 v	285-510
C618		.01 $\mu$ f	PTM	Fixed	400 v	285-510
C628		.01 $\mu$ f	PTM	Fixed	400 v	285-510
C640		125 $\mu$ f	EMC	Fixed	350 v	290-044
C649		2 x 40 $\mu$ f	EMC	Fixed	250 v	290-040
C650		.01 $\mu$ f	PTM	Fixed	400 v	285-510
C671		2 x 200 $\mu$ f	EMC	Fixed	250 v	290-082
C682		.01 $\mu$ f	PTM	Fixed	400 v	285-510
C688		.01 $\mu$ f	PTM	Fixed	400 v	285-510
C700		125 $\mu$ f	EMC	Fixed	450 v	290-045
C710		.01 $\mu$ f	PTM	Fixed	600 v	285-511
C730		100 $\mu$ f	EMC	Fixed	350 v	290-081
C731		100 $\mu$ f	EMC	Fixed	350 v	
C740		.01 $\mu$ f	PTM	Fixed	400 v	285-510
C760A,B		2 x 40 $\mu$ f	EMC	Fixed	450 v	290-042
C771		2 x 20 $\mu$ f	EMC	Fixed	450 v	290-036
C773		2 x 20 $\mu$ f	EMC	Fixed	450 v	290-037
C775A,B,C		3 x 10 $\mu$ f	EMC	Fixed	450 v	290-033
C776A,B		2 x 15 $\mu$ f	EMC	Fixed	350 v	290-034
C778A,B		2 x 15 $\mu$ f	EMC	Fixed	350 v	290-034
C780		2 x 15 $\mu$ f	EMC	Fixed	350 v	290-034
C784		6.25 $\mu$ f	EMT	Fixed	300 v	290-000
C785		2 x 15 $\mu$ f	EMC	Fixed	350 v	290-056
C793		1 $\mu$ f	PTM	Fixed	400 v	285-540
C803		.001 $\mu$ f	Cer.	Fixed	500 v	Use 283-000
C806		.01 $\mu$ f	PTM	Fixed	400 v	285-510
C808		.001 $\mu$ f	PTM	Fixed	1000 v	285-502
C819	X1440-up	.1 $\mu$ f	Cer.	Fixed	200 v	Use 283-057
C820		.01 $\mu$ f	Cer.	Fixed	2000 v	283-011
C821		.01 $\mu$ f	Cer.	Fixed	2000 v	283-011
C827		.01 $\mu$ f	Cer.	Fixed	2000 v	283-011
C828		.01 $\mu$ f	Cer.	Fixed	2000 v	283-011
C831		.01 $\mu$ f	Cer.	Fixed	2000 v	283-011
C842		.047 $\mu$ f	PTM	Fixed	400 v	285-519
C843		.01 $\mu$ f	Cer.	Fixed	2000 v	283-011
C844		.01 $\mu$ f	Cer.	Fixed	2000 v	283-011
C848		.01 $\mu$ f	Cer.	Fixed	2000 v	283-011
C871		330 $\mu$ f	Mica	Fixed	500 v	10% 283-518
C874		330 $\mu$ f	Mica	Fixed	500 v	10% 283-518
C885		27 $\mu$ f	Cer.	Fixed	500 v	$\pm 5.4 \mu$ f 281-513
C897		.001 $\mu$ f	Cer.	Fixed	500 v	283-000
C903		.001 $\mu$ f	PTM	Fixed	600 v	285-501
C906		.01 $\mu$ f	PTM	Fixed	400 v	285-510
C908		.001 $\mu$ f	PTM	Fixed	1000 v	285-502
C919	X1440-up	.1 $\mu$ f	Cer.	Fixed	200 v	Use 283-057
C920		.01 $\mu$ f	Cer.	Fixed	2000 v	283-011
C921		.01 $\mu$ f	Cer.	Fixed	2000 v	283-011
C927		.01 $\mu$ f	Cer.	Fixed	2000 v	283-011
C928	X444-up	.01 $\mu$ f	Cer.	Fixed	2000 v	283-011
C931		.01 $\mu$ f	Cer.	Fixed	2000 v	283-011
C932		.001 $\mu$ f	Cer.	Fixed	6000 v	283-018

Capacitors (continued)

						Tektronix Part Number
C933	500 $\mu\mu\text{f}$	Cer.	Fixed	10,000		281-556
C935	500 $\mu\mu\text{f}$	Cer.	Fixed	10,000		281-556
C942	.047 $\mu\text{f}$	PTM	Fixed	400 v		285-519
C943	.01 $\mu\text{f}$	Cer.	Fixed	2000 v		283-011
C944	.01 $\mu\text{f}$	Cer.	Fixed	2000 v		283-011
C948	.01 $\mu\text{f}$	Cer.	Fixed	2000 v		283-011
C1003	2 x 20 $\mu\text{f}$	EMC	Fixed	450 v		290-036
C1005	10 x 20 x 40 $\mu\text{f}$	EMC	Fixed	475 v		290-063
C1007	.1 $\mu\text{f}$	PTM	Fixed	400 v		285-526
C1013	.005 $\mu\text{f}$	Cer.	Fixed	500 v		283-001
C1029	.001 $\mu\text{f}$	Cer.	Fixed	500 v		283-000
C1031	.005 $\mu\text{f}$	Cer.	Fixed	500 v		283-001
C1039	.001 $\mu\text{f}$	Cer.	Fixed	500 v	$\pm 100 \mu\mu\text{f}$	281-536
C1043	.005 $\mu\text{f}$	Cer.	Fixed	500 v		283-001
C1049	.001 $\mu\text{f}$	Cer.	Fixed	500 v	$\pm 100 \mu\mu\text{f}$	281-536
C1052	.001 $\mu\text{f}$	Cer.	Fixed	500 v		283-000
C1054	.005 $\mu\text{f}$	Cer.	Fixed	500 v		283-001
C1056	150 $\mu\mu\text{f}$	Cer.	Fixed	500 v	$\pm 30 \mu\mu\text{f}$	281-524
C1062	.001 $\mu\text{f}$	Cer.	Fixed	500 v		283-000
C1075	8-50 $\mu\mu\text{f}$	Cer.	Var.			281-022
C1077	8-50 $\mu\mu\text{f}$	Cer.	Var.			281-022
C1078	.7-3 $\mu\mu\text{f}$	Tub.	Var.			281-027
C1085	.005 $\mu\text{f}$	Cer.	Fixed	500 v		283-001
C1093A,B,C,D	4 x 75 $\mu\text{f}$	EMC	Fixed	150 v		290-071
C1102	.001 $\mu\text{f}$	Cer.	Fixed	500 v		283-000
C1104	.7-3 $\mu\mu\text{f}$	Tub.	Var.			281-027
C1105	150 $\mu\mu\text{f}$	Cer.	Fixed	500 v	$\pm 30 \mu\mu\text{f}$	281-524
C1106	150 $\mu\mu\text{f}$	Cer.	Fixed	500 v	$\pm 30 \mu\mu\text{f}$	281-524
C1112	.001 $\mu\text{f}$	Cer.	Fixed	500 v		283-000
C1122	.001 $\mu\text{f}$	Cer.	Fixed	500 v		283-000
C1124	.7-3 $\mu\mu\text{f}$	Tub.	Var.			281-027
C1126	150 $\mu\mu\text{f}$	Cer.	Fixed	500 v	$\pm 30 \mu\mu\text{f}$	281-524
C1132	.001 $\mu\text{f}$	Cer.	Fixed	500 v		283-000
C1142	.001 $\mu\text{f}$	Cer.	Fixed	500 v		283-000
C1144	.7-3 $\mu\mu\text{f}$	Tub.	Var.			281-027
C1146	150 $\mu\mu\text{f}$	Cer.	Fixed	500 v	$\pm 30 \mu\mu\text{f}$	281-524
C1152	.001 $\mu\text{f}$	Cer.	Fixed	500 v		283-000
C1162	.001 $\mu\text{f}$	Cer.	Fixed	500 v		283-000
C1164	.7-3 $\mu\mu\text{f}$	Tub.	Var.			281-027
C1166	150 $\mu\mu\text{f}$	Cer.	Fixed	500 v	$\pm 30 \mu\mu\text{f}$	281-524
C1172	.001 $\mu\text{f}$	Cer.	Fixed	500 v		283-000
C1182	.001 $\mu\text{f}$	Cer.	Fixed	500 v		283-000
C1184	.7-3 $\mu\mu\text{f}$	Tub.	Var.			281-027
C1186	150 $\mu\mu\text{f}$	Cer.	Fixed	500 v	$\pm 30 \mu\mu\text{f}$	281-524
C1192	.001 $\mu\text{f}$	Cer.	Fixed	500 v		283-000
C1202	.001 $\mu\text{f}$	Cer.	Fixed	500 v		283-000
C1204	.7-3 $\mu\mu\text{f}$	Tub.	Var.			281-027
C1205	150 $\mu\mu\text{f}$	Cer.	Fixed	500 v	$\pm 30 \mu\mu\text{f}$	281-524
C1208	.005 $\mu\text{f}$	Cer.	Fixed	500 v		283-001
C1212	.001 $\mu\text{f}$	Cer.	Fixed	500 v		283-000

Capacitors (continued)

					Tektronix Part Number
C1223	.001 $\mu$ f	Cer.	Fixed	500 v	283-000
C1228	.005 $\mu$ f	Cer.	Fixed	500 v	283-001
C1301	.7-3 $\mu$ $\mu$ f	Tub.	Var.		281-027
C1302	.7-3 $\mu$ $\mu$ f	Tub.	Var.		281-027
C1303	.7-3 $\mu$ $\mu$ f	Tub.	Var.		281-027
C1304	.7-3 $\mu$ $\mu$ f	Tub.	Var.		281-027
C1305	.7-3 $\mu$ $\mu$ f	Tub.	Var.		281-027
C1306	.7-3 $\mu$ $\mu$ f	Tub.	Var.		281-027
C1307	.7-3 $\mu$ $\mu$ f	Tub.	Var.		281-027
C1308	.7-3 $\mu$ $\mu$ f	Tub.	Var.		281-027
C1309	.7-3 $\mu$ $\mu$ f	Tub.	Var.		281-027
C1310	.7-3 $\mu$ $\mu$ f	Tub.	Var.		281-027
C1311	.7-3 $\mu$ $\mu$ f	Tub.	Var.		281-027
C1312	.7-3 $\mu$ $\mu$ f	Tub.	Var.		281-027
C1313	.7-3 $\mu$ $\mu$ f	Tub.	Var.		281-027
C1314	.7-3 $\mu$ $\mu$ f	Tub.	Var.		281-027
C1315	.7-3 $\mu$ $\mu$ f	Tub.	Var.		281-027
C1316	.7-3 $\mu$ $\mu$ f	Tub.	Var.		281-027
C1317	.7-3 $\mu$ $\mu$ f	Tub.	Var.		281-027
C1318	.7-3 $\mu$ $\mu$ f	Tub.	Var.		281-027
C1319	.7-3 $\mu$ $\mu$ f	Tub.	Var.		281-027
C1320	.7-3 $\mu$ $\mu$ f	Tub.	Var.		281-027
C1321	.7-3 $\mu$ $\mu$ f	Tub.	Var.		281-027
C1322	.7-3 $\mu$ $\mu$ f	Tub.	Var.		281-027
C1323	.7-3 $\mu$ $\mu$ f	Tub.	Var.		281-027
C1324	.7-3 $\mu$ $\mu$ f	Tub.	Var.		281-027
C1325	.7-3 $\mu$ $\mu$ f	Tub.	Var.		281-027
C1326	.7-3 $\mu$ $\mu$ f	Tub.	Var.		281-027
C1327	.7-3 $\mu$ $\mu$ f	Tub.	Var.		281-027
C1328	.7-3 $\mu$ $\mu$ f	Tub.	Var.		281-027
C1329	.7-3 $\mu$ $\mu$ f	Tub.	Var.		281-027
C1330	.7-3 $\mu$ $\mu$ f	Tub.	Var.		281-027
C1331	.7-3 $\mu$ $\mu$ f	Tub.	Var.		281-027
C1332	.7-3 $\mu$ $\mu$ f	Tub.	Var.		281-027
C1333	.7-3 $\mu$ $\mu$ f	Tub.	Var.		281-027
C1334	.7-3 $\mu$ $\mu$ f	Tub.	Var.		281-027
C1335	.7-3 $\mu$ $\mu$ f	Tub.	Var.		281-027
C1336	.7-3 $\mu$ $\mu$ f	Tub.	Var.		281-027
C1337	.7-3 $\mu$ $\mu$ f	Tub.	Var.		281-027
C1338	.7-3 $\mu$ $\mu$ f	Tub.	Var.		281-027
C1339	.7-3 $\mu$ $\mu$ f	Tub.	Var.		281-027
C1340	.7-3 $\mu$ $\mu$ f	Tub.	Var.		281-027
C1341	.7-3 $\mu$ $\mu$ f	Tub.	Var.		281-027
C1342	.7-3 $\mu$ $\mu$ f	Tub.	Var.		281-027
C1343	.7-3 $\mu$ $\mu$ f	Tub.	Var.		281-027
C1344	.7-3 $\mu$ $\mu$ f	Tub.	Var.		281-027
C1345	.7-3 $\mu$ $\mu$ f	Tub.	Var.		281-027
C1346	.7-3 $\mu$ $\mu$ f	Tub.	Var.		281-027
C1347	.7-3 $\mu$ $\mu$ f	Tub.	Var.		281-027
C1348	.7-3 $\mu$ $\mu$ f	Tub.	Var.		281-027

Capacitors (continued)

							Tektronix Part Number
C1349	7-3 $\mu\text{mf}$	Tub.	Var.				281-027
C1350	7-3 $\mu\text{mf}$	Tub.	Var.				281-027
C1359	1 $\mu\text{mf}$	Cer.	Fixed	500 v	$\pm 0.2 \mu\text{mf}$		281-538
C1360	1.5 $\mu\text{mf}$	Cer.	Fixed	500 v	$\pm 0.25 \mu\text{mf}$		281-529
C1361	1.5 $\mu\text{mf}$	Cer.	Fixed	500 v	$\pm 0.25 \mu\text{mf}$		281-529
C1362	1.5 $\mu\text{mf}$	Cer.	Fixed	500 v	$\pm 0.25 \mu\text{mf}$		281-529
C1363	1.5 $\mu\text{mf}$	Cer.	Fixed	500 v	$\pm 0.25 \mu\text{mf}$		281-529
C1364	1.5 $\mu\text{mf}$	Cer.	Fixed	500 v	$\pm 0.25 \mu\text{mf}$		281-529
C1365	1.5 $\mu\text{mf}$	Cer.	Fixed	500 v	$\pm 0.25 \mu\text{mf}$		281-529
C1366	1.5 $\mu\text{mf}$	Cer.	Fixed	500 v	$\pm 0.25 \mu\text{mf}$		281-529
C1367	1.5 $\mu\text{mf}$	Cer.	Fixed	500 v	$\pm 0.25 \mu\text{mf}$		281-529
C1368	1.5 $\mu\text{mf}$	Cer.	Fixed	500 v	$\pm 0.25 \mu\text{mf}$		281-529
C1369	1.5 $\mu\text{mf}$	Cer.	Fixed	500 v	$\pm 0.25 \mu\text{mf}$		281-529
C1370	1.5 $\mu\text{mf}$	Cer.	Fixed	500 v	$\pm 0.25 \mu\text{mf}$		281-529
C1371	1.5 $\mu\text{mf}$	Cer.	Fixed	500 v	$\pm 0.25 \mu\text{mf}$		281-529
C1372	1.5 $\mu\text{mf}$	Cer.	Fixed	500 v	$\pm 0.25 \mu\text{mf}$		281-529
C1373	1.5 $\mu\text{mf}$	Cer.	Fixed	500 v	$\pm 0.25 \mu\text{mf}$		281-529
C1374	1.5 $\mu\text{mf}$	Cer.	Fixed	500 v	$\pm 0.25 \mu\text{mf}$		281-529
C1375	1.5 $\mu\text{mf}$	Cer.	Fixed	500 v	$\pm 0.25 \mu\text{mf}$		281-529
C1380	.68 $\mu\text{mf}$	Cer.	Fixed	500 v	$\pm 0.136 \mu\text{mf}$		281-537
C1381	.68 $\mu\text{mf}$	Cer.	Fixed	500 v	$\pm 0.136 \mu\text{mf}$		281-537
C1382	.68 $\mu\text{mf}$	Cer.	Fixed	500 v	$\pm 0.136 \mu\text{mf}$		281-537
C1383	.68 $\mu\text{mf}$	Cer.	Fixed	500 v	$\pm 0.136 \mu\text{mf}$		281-537
C1423	.005 $\mu\text{f}$	Cer.	Fixed	500 v			283-001
C1424	.005 $\mu\text{f}$	Cer.	Fixed	500 v			283-001
C1433	.005 $\mu\text{f}$	Cer.	Fixed	500 v			283-001
C2003	2x20 $\mu\text{f}$	EMC	Fixed	450 v			290-036
C2005A,B,C	10x20x40 $\mu\text{f}$	EMC	Fixed	475 v			290-063
C2007	.1 $\mu\text{f}$	PTM	Fixed	400 v			285-526
C2013	.005 $\mu\text{f}$	Cer.	Fixed	500 v			283-001
C2029	.001 $\mu\text{f}$	Cer.	Fixed	500 v			283-000
C2031	.005 $\mu\text{f}$	Cer.	Fixed	500 v			283-001
C2039	.001 $\mu\text{mf}$	Cer.	Fixed	500 v	$\pm 100 \mu\text{mf}$		281-536
C2043	.005 $\mu\text{f}$	Cer.	Fixed	500 v			283-001
C2049	.001 $\mu\text{mf}$	Cer.	Fixed	500 v	$\pm 100 \mu\text{mf}$		281-536
C2052	.001 $\mu\text{f}$	Cer.	Fixed	500 v			283-000
C2054	.005 $\mu\text{f}$	Cer.	Fixed	500 v			283-001
C2056	150 $\mu\text{mf}$	Cer.	Fixed	500 v	$\pm 30 \mu\text{mf}$		281-524
C2062	.001 $\mu\text{mf}$	Cer.	Fixed	500 v			283-000
C2075	8-50 $\mu\text{mf}$	Cer.	Var.				281-022
C2077	8-50 $\mu\text{mf}$	Cer.	Var.				281-022
C2078	7-3 $\mu\text{mf}$	Tub.	Var.				281-027
C2085	.005 $\mu\text{f}$	Cer.	Fixed	500 v			283-001
C2093A,B,C,D	4x75 $\mu\text{f}$	EMC	Fixed	150 v			290-071
C2102	.001 $\mu\text{f}$	Cer.	Fixed	500 v			283-000
C2104	7-3 $\mu\text{mf}$	Tub.	Var.				281-027
C2105	150 $\mu\text{mf}$	Cer.	Fixed	500 v	$\pm 30 \mu\text{mf}$		281-524
C2106	150 $\mu\text{mf}$	Cer.	Fixed	500 v	$\pm 30 \mu\text{mf}$		281-524
C2112	.001 $\mu\text{f}$	Cer.	Fixed	500 v			283-000
C2122	.001 $\mu\text{f}$	Cer.	Fixed	500 v			283-000

## Resistors (continued)

							Tektronix Part Number
C2124	.7-3 $\mu\mu f$	Tub.	Var.				281-027
C2126	150 $\mu\mu f$	Cer.	Fixed	500 v	$\pm 30 \mu\mu f$		281-524
C2132	.001 $\mu f$	Cer.	Fixed	500 v			283-000
C2142	.001 $\mu f$	Cer.	Fixed	500 v			283-000
C2144	.7-3 $\mu\mu f$	Tub.	Var.				281-027
C2146	150 $\mu\mu f$	Cer.	Fixed	500 v	$\pm 30 \mu\mu f$		281-524
C2152	.001 $\mu f$	Cer.	Fixed	500 v			283-000
C2162	.001 $\mu f$	Cer.	Fixed	500 v			283-000
C2164	.7-3 $\mu\mu f$	Tub.	Var.				281-027
C2166	150 $\mu\mu f$	Cer.	Fixed	500 v	$\pm 30 \mu\mu f$		281-524
C2172	.001 $\mu f$	Cer.	Fixed	500 v			283-000
C2182	.001 $\mu f$	Cer.	Fixed	500 v			283-000
C2184	.7-3 $\mu\mu f$	Tub.	Var.				281-027
C2186	150 $\mu\mu f$	Cer.	Fixed	500 v	$\pm 30 \mu\mu f$		281-524
C2192	.001 $\mu f$	Cer.	Fixed	500 v			283-000
C2202	.001 $\mu f$	Cer.	Fixed	500 v			283-000
C2204	.7-3 $\mu\mu f$	Tub.	Var.				281-027
C2205	150 $\mu\mu f$	Cer.	Fixed	500 v	$\pm 30 \mu\mu f$		281-524
C2208	.005 $\mu f$	Cer.	Fixed	500 v			283-001
C2212	.001 $\mu f$	Cer.	Fixed	500 v			283-000
C2223	.001 $\mu f$	Cer.	Fixed	500 v			283-000
C2228	.005 $\mu f$	Cer.	Fixed	500 v			283-001
C2301	.7-3 $\mu\mu f$	Tub.	Var.				281-027
C2302	.7-3 $\mu\mu f$	Tub.	Var.				281-027
C2303	.7-3 $\mu\mu f$	Tub.	Var.				281-027
C2304	.7-3 $\mu\mu f$	Tub.	Var.				281-027
C2305	.7-3 $\mu\mu f$	Tub.	Var.				281-027
C2306	.7-3 $\mu\mu f$	Tub.	Var.				281-027
C2307	.7-3 $\mu\mu f$	Tub.	Var.				281-027
C2308	.7-3 $\mu\mu f$	Tub.	Var.				281-027
C2309	.7-3 $\mu\mu f$	Tub.	Var.				281-027
C2310	.7-3 $\mu\mu f$	Tub.	Var.				281-027
C2311	.7-3 $\mu\mu f$	Tub.	Var.				281-027
C2312	.7-3 $\mu\mu f$	Tub.	Var.				281-027
C2313	.7-3 $\mu\mu f$	Tub.	Var.				281-027
C2314	.7-3 $\mu\mu f$	Tub.	Var.				281-027
C2315	.7-3 $\mu\mu f$	Tub.	Var.				281-027
C2316	.7-3 $\mu\mu f$	Tub.	Var.				281-027
C2317	.7-3 $\mu\mu f$	Tub.	Var.				281-027
C2318	.7-3 $\mu\mu f$	Tub.	Var.				281-027
C2319	.7-3 $\mu\mu f$	Tub.	Var.				281-027
C2320	.7-3 $\mu\mu f$	Tub.	Var.				281-027
C2321	.7-3 $\mu\mu f$	Tub.	Var.				281-027
C2322	.7-3 $\mu\mu f$	Tub.	Var.				281-027
C2323	.7-3 $\mu\mu f$	Tub.	Var.				281-027
C2324	.7-3 $\mu\mu f$	Tub.	Var.				281-027
C2325	.7-3 $\mu\mu f$	Tub.	Var.				281-027
C2326	.7-3 $\mu\mu f$	Tub.	Var.				281-027
C2327	.7-3 $\mu\mu f$	Tub.	Var.				281-027
C2328	.7-3 $\mu\mu f$	Tub.	Var.				281-027
C2329	.7-3 $\mu\mu f$	Tub.	Var.				281-027
C2330	.7-3 $\mu\mu f$	Tub.	Var.				281-027
C2331	.7-3 $\mu\mu f$	Tub.	Var.				281-027
C2332	.7-3 $\mu\mu f$	Tub.	Var.				281-027
C2333	.7-3 $\mu\mu f$	Tub.	Var.				281-027

**Capacitors (continued)**

					Tektronix Part Number
C2334	7-3 $\mu\mu\text{f}$	Tub.	Var.		281-027
C2335	7-3 $\mu\mu\text{f}$	Tub.	Var.		281-027
C2336	7-3 $\mu\mu\text{f}$	Tub.	Var.		281-027
C2337	7-3 $\mu\mu\text{f}$	Tub.	Var.		281-027
C2338	7-3 $\mu\mu\text{f}$	Tub.	Var.		281-027
C2339	7-3 $\mu\mu\text{f}$	Tub.	Var.		281-027
C2340	7-3 $\mu\mu\text{f}$	Tub.	Var.		281-027
C2341	7-3 $\mu\mu\text{f}$	Tub.	Var.		281-027
C2342	7-3 $\mu\mu\text{f}$	Tub.	Var.		281-027
C2343	7-3 $\mu\mu\text{f}$	Tub.	Var.		281-027
C2344	7-3 $\mu\mu\text{f}$	Tub.	Var.		281-027
C2345	7-3 $\mu\mu\text{f}$	Tub.	Var.		281-027
C2346	7-3 $\mu\mu\text{f}$	Tub.	Var.		281-027
C2347	7-3 $\mu\mu\text{f}$	Tub.	Var.		281-027
C2348	7-3 $\mu\mu\text{f}$	Tub.	Var.		281-027
C2349	7-3 $\mu\mu\text{f}$	Tub.	Var.		281-027
C2350	7-3 $\mu\mu\text{f}$	Tub.	Var.		281-027
C2359	1 $\mu\mu\text{f}$	Cer.	Fixed	500 v	$\pm 0.2 \mu\mu\text{f}$ 281-538
C2360	1.5 $\mu\mu\text{f}$	Cer.	Fixed	500 v	$\pm 0.25 \mu\mu\text{f}$ 281-529
C2361	1.5 $\mu\mu\text{f}$	Cer.	Fixed	500 v	$\pm 0.25 \mu\mu\text{f}$ 281-529
C2362	1.5 $\mu\mu\text{f}$	Cer.	Fixed	500 v	$\pm 0.25 \mu\mu\text{f}$ 281-529
C2363	1.5 $\mu\mu\text{f}$	Cer.	Fixed	500 v	$\pm 0.25 \mu\mu\text{f}$ 281-529
C2364	1.5 $\mu\mu\text{f}$	Cer.	Fixed	500 v	$\pm 0.25 \mu\mu\text{f}$ 281-529
C2365	1.5 $\mu\mu\text{f}$	Cer.	Fixed	500 v	$\pm 0.25 \mu\mu\text{f}$ 281-529
C2366	1.5 $\mu\mu\text{f}$	Cer.	Fixed	500 v	$\pm 0.25 \mu\mu\text{f}$ 281-529
C2367	1.5 $\mu\mu\text{f}$	Cer.	Fixed	500 v	$\pm 0.25 \mu\mu\text{f}$ 281-529
C2368	1.5 $\mu\mu\text{f}$	Cer.	Fixed	500 v	$\pm 0.25 \mu\mu\text{f}$ 281-529
C2369	1.5 $\mu\mu\text{f}$	Cer.	Fixed	500 v	$\pm 0.25 \mu\mu\text{f}$ 281-529
C2370	1.5 $\mu\mu\text{f}$	Cer.	Fixed	500 v	$\pm 0.25 \mu\mu\text{f}$ 281-529
C2371	1.5 $\mu\mu\text{f}$	Cer.	Fixed	500 v	$\pm 0.25 \mu\mu\text{f}$ 281-529
C2372	1.5 $\mu\mu\text{f}$	Cer.	Fixed	500 v	$\pm 0.25 \mu\mu\text{f}$ 281-529
C2373	1.5 $\mu\mu\text{f}$	Cer.	Fixed	500 v	$\pm 0.25 \mu\mu\text{f}$ 281-529
C2374	1.5 $\mu\mu\text{f}$	Cer.	Fixed	500 v	$\pm 0.25 \mu\mu\text{f}$ 281-529
C2375	1.5 $\mu\mu\text{f}$	Cer.	Fixed	500 v	$\pm 0.25 \mu\mu\text{f}$ 281-529
C2380	.68 $\mu\mu\text{f}$	Cer.	Fixed	500 v	$\pm 0.136 \mu\mu\text{f}$ 281-537
C2381	.68 $\mu\mu\text{f}$	Cer.	Fixed	500 v	$\pm 0.136 \mu\mu\text{f}$ 281-537
C2382	.68 $\mu\mu\text{f}$	Cer.	Fixed	500 v	$\pm 0.136 \mu\mu\text{f}$ 281-537
C2383	.68 $\mu\mu\text{f}$	Cer.	Fixed	500 v	$\pm 0.136 \mu\mu\text{f}$ 281-537
C2423	.005 $\mu\text{f}$	Cer.	Fixed	500 v	283-001
C2424	.005 $\mu\text{f}$	Cer.	Fixed	500 v	283-001
C2433	.005 $\mu\text{f}$	Cer.	Fixed	500 v	283-001

**Diodes**

D642A,B,C,D	Silicon Diode	152-047
D672A,B,C,D	Silicon Diode	152-050
D702A,B	Silicon Diode	152-047
D722	Silicon Diode	152-047
D732A,B	Silicon Diode	152-047
D762A,B,C,D	Silicon Diode	152-047

**Fuses**

F601	7 amp, Slo Blo 3 AG	117 V oper. 50 & 60 cycle	159-036
F601	4 amp, Slo Blo 3 AG	234 V oper. 50 & 60 cycle	159-027
F602	5 amp, Slo Blo 3 AG	117 V oper. 50 & 60 cycle	159-006
F602	3 amp, Slo Blo 3 AG	234 V oper. 50 & 60 cycle	159-005
F1054	X1740-up	Fast Blo 150MA	159-049
F2054	X1740-up	Fast Blo 150MA	159-049

## Relays

				Tektronix Part Number
K600		6N045T 45 sec. Time Delay		148-002
K601		Holding Relay		148-011

## Inductors

L564		280 $\mu$ h	Fixed		*108-015
L790	101-1319	Reactor	Fixed		use 050-045
L790	1320-up	Reactor	Fixed		*108-236
L973		Beam Rotator Coil	Fixed		*108-158
L1014		1.8-3.9 $\mu$ h	Var.	core 276-506	*114-112
L1015		.45 $\mu$ h	Fixed		*108-062
L1024		1.8-3.9 $\mu$ h	Var.	core 276-506	*114-112
L1025		.45 $\mu$ h	Fixed		*108-062
L1033	X1445-up	Core Ferramic Suppressor			276-507
L1036		3-.55 $\mu$ h	Var.	core 276-506	*114-111
L1046		.3-.55 $\mu$ h	Var.	core 276-506	*114-111
L1064		8.4 $\mu$ h	Fixed		*108-157
L1071		.3-.5 $\mu$ h	Var.	core 276-506	*114-092
L1073		.3-.5 $\mu$ h	Var.	core 276-506	*114-092
L1103		6 section grid line coil	Fixed		*108-145
L1104		7 section plate line coil	Fixed		*108-139
L1113		6 section grid line coil	Fixed		*108-145
L1114		7 section plate line coil	Fixed		*108-139
L1304	101-219	30 section coil	Fixed		use *108-177
L1304	220-up	30 section coil	Fixed		*108-177
L1305	101-219	30 section coil	Fixed		use *108-177
L1305	220-up	30 section coil	Fixed		*108-177
L1334	101-219	20 section coil	Fixed		use *108-176
L1334	220-up	20 section coil	Fixed		*108-176
L1335	101-219	20 section coil	Fixed		use *108-176
L1335	250-up	20 section coil	Fixed		*108-176
L1354		.9-1.6 $\mu$ h	Var.	core 276-506	*114-038
L1355		.9-1.6 $\mu$ h	Var.	core 276-506	*114-038
L1420	X1445-up	Core Ferramic Suppressor			276-507
L2014		1.8-3.9 $\mu$ h	Var.	core 276-506	*114-112
L2015		.45 $\mu$ h	Fixed		*108-062
L2024		1.8-3.9 $\mu$ h	Var.	core 276-506	*114-112
L2033	X1445-up	Core Ferramic Suppressor			276-507
L2025		.45 $\mu$ h	Fixed		*108-062
L2036		.3-.55 $\mu$ h	Var.	core 276-506	*114-111
L2046		.3-.55 $\mu$ h	Var.	core 276-506	*114-111
L2064		8.4 $\mu$ h	Fixed		*108-157
L2071		.3-.5 $\mu$ h	Var.	core 276-506	*114-092
L2073		.3-.5 $\mu$ h	Var.	core 276-506	*114-092
L2103		6 section grid line coil	Fixed		*108-145
L2104		7 section plate line coil	Fixed		*108-139
L2113		6 section grid line coil	Fixed		*108-145
L2114		7 section plate line coil	Fixed		*108-139
L2304	101-219	30 section coil	Fixed		use *108-177
L2304	220-up	30 section coil	Fixed		*108-177
L2305	101-219	30 section coil	Fixed		use *108-177
L2305	220-up	30 section coil	Fixed		*108-177
L2334	101-219	20 section coil	Fixed		use *108-176
L2334	220-up	20 section coil	Fixed		*108-176
L2335	101-219	20 section coil	Fixed		use *108-176
L2335	220-up	20 section coil	Fixed		*108-176
L2354		.9-1.6 $\mu$ h	Var.	core 276-506	*114-038

Inductors (continued)

Tektronix  
Part Number  
\*114-038  
276-507

L2355 .9-1.6  $\mu$ h Var. core 276-506  
L2420 X1445-up Core Ferramic Suppressor

Resistors

R306C		900 k	1/2 w	Fixed	Prec.	1%	309-111
R306E		100 k	1/2 w	Fixed	Prec.	1%	309-045
R311		1 k	1/2 w	Fixed	Comp.	10%	302-102
R313	101-4939	47 k	1 w	Fixed	Comp.	10%	304-473
R313	4940-up	33 k	2 w	Fixed	Comp.	10%	306-333
R315		15 k	1/2 w	Var.	Comp.	20%	Use 311-112
R317	101-4939	33 k	2 w	Fixed	Comp.	10%	306-333
R317	4940-up	27 k	2 w	Fixed	Comp.	10%	306-273
R319	101-4939	47 k	1 w	Fixed	Comp.	10%	304-473
R319	4949-up	33 k	2 w	Fixed	Comp.	10%	306-333
R321		100 $\Omega$	1/2 w	Fixed	Comp.	10%	302-101
R322		3.3 k	1/2 w	Fixed	Comp.	10%	302-332
R324		220 k	1/2 w	Fixed	Comp.	10%	302-224
R326		100 k		Var.	Comp.		311-026
R330		1.94 meg	1/2 w	Fixed	Prec.	1%	309-022
R331		3.5 meg	1/2 w	Fixed	Prec.	1%	309-086
R332		18 k	1/2 w	Fixed	Comp.	10%	302-183
R333		100 k		Var.	Comp.		311-026
R334		36 k	1/2 w	Fixed	Comp.	5%	301-363
R340		2.2 k	1/2 w	Fixed	Comp.	10%	302-222
R341		47 $\Omega$	1/2 w	Fixed	Comp.	10%	302-470
R343		100 k	1 w	Fixed	Comp.	10%	304-104
R350		120 k	1/2 w	Fixed	Prec.	1%	309-091
R351		50 k	.2 w	Var.	Comp.	20%	311-125
R352		47 $\Omega$	1/2 w	Fixed	Comp.	10%	302-470
R353		100 k	1 w	Fixed	Comp.	10%	304-104
R355		400 k	1 w	Fixed	Prec.	1%	310-094
R356		400 k	1 w	Fixed	Prec.	1%	310-094
R357		22 k	1/2 w	Fixed	Comp.	10%	302-223
R358		20 k		Var.	Comp.		311-018
R361		47 $\Omega$	1/2 w	Fixed	Comp.	10%	302-470
R364		6-25 k	5 w	Fixed	Prec.	1%	310-506
R366		47 $\Omega$	1/2 w	Fixed	Comp.	10%	302-470
R372		2.25 k		Var.	Comp.		311-071
R374		2.2 k	1 w	Fixed	Comp.	10%	304-222
R375		2.2 k	1 w	Fixed	Comp.	10%	304-222
R376		6 k	5 w	Fixed	WW	1%	308-112
R380		100 $\Omega$	1/2 w	Fixed	Comp.	10%	302-101
R381		47 $\Omega$	1/2 w	Fixed	Comp.	10%	302-470
R384		6-30 k	5 w	Fixed	Prec.	1%	310-507
R386		47 $\Omega$	1/2 w	Fixed	Comp.	10%	302-470
R387		39 k	2 w	Fixed	Comp.	10%	306-393
R388		39 k	2 w	Fixed	Comp.	10%	306-393
R390		390 $\Omega$	1/2 w	Fixed	Comp.	10%	302-391
R391		47 $\Omega$	1/2 w	Fixed	Comp.	10%	302-470
R392		2.2 k	1/2 w	Fixed	Comp.	10%	302-222
R394		470 k	1/2 w	Fixed	Comp.	10%	302-474
R395		820 k	1/2 w	Fixed	Comp.	10%	302-824
R396		820 k	1/2 w	Fixed	Comp.	10%	302-824
R397		470 k	1/2 w	Fixed	Comp.	10%	302-474
R406C		900 k	1/2 w	Fixed	Prec.	1%	309-111
R406E		100 k	1/2 w	Fixed	Prec.	1%	309-045
R411		1 k	1/2 w	Fixed	Comp.	10%	302-102

## Resistors (continued)

							Tektronix Part Number
R413	101-4939	47 k	1 w	Fixed	Comp.	10%	304-473
R413	4940-up	33 k	2 w	Fixed	Comp.	10%	306-333
R415		15 k	1/2 w	Fixed	Comp.	20%	Use 311-112
R417	101-4939	33 k	2 w	Fixed	Comp.	10%	306-333
R417	4940-up	27 k	2 w	Fixed	Comp.	10%	306-273
R419	101-4939	47 k	1 w	Fixed	Comp.	10%	304-473
R419	4940-up	33 k	2 w	Fixed	Comp.	10%	306-333
R421		100 Ω	1/2 w	Fixed	Comp.	10%	302-101
R422		3.3 k	1/2 w	Fixed	Comp.	10%	302-332
R423		220 k	1/2 w	Fixed	Comp.	10%	302-224
R426		100 k		Var.	Comp.		311-026
R430		1.94 meg	1/2 w	Fixed	Prec.	1%	309-022
R431		3.5 meg	1/2 w	Fixed	Prec.	1%	309-086
R432		18 k	1/2 w	Fixed	Comp.	10%	302-183
R433		100 k		Var.	Comp.		311-026
R434		36 k	1/2 w	Fixed	Comp.	5%	301-363
R440		2.2 k	1/2 w	Fixed	Comp.	10%	302-222
R441		47 Ω	1/2 w	Fixed	Comp.	10%	302-470
R443		100 k	1 w	Fixed	Comp.	10%	304-104
R450		120 k	1/2 w	Fixed	Prec.	1%	309-091
R451		50 k	.2 w	Var.	Comp.	20%	311-125
R452		47 Ω	1/2 w	Fixed	Comp.	10%	302-470
R453		100 k	1 w	Fixed	Comp.	10%	304-104
R455		400 k	1 w	Fixed	Prec.	1%	310-094
R456		400 k	1 w	Fixed	Prec.	1%	310-094
R457		22 k	1/2 w	Fixed	Comp.	10%	302-223
R458		20 k		Var.	Comp.		311-018
R461		47 Ω	1/2 w	Fixed	Comp.	10%	302-470
R464		6-25 k	5 w	Fixed	Prec.	1%	310-506
R466		47 Ω	1/2 w	Fixed	Comp.	10%	302-470
R472		2.25 k		Var.	Comp.		311-071
R474		2.2 k	1 w	Fixed	Comp.	10%	304-222
R475		2.2 k	1 w	Fixed	Comp.	10%	304-222
R476		6 k	5 w	Fixed	WW	1%	308-112
R480		100 Ω	1/2 w	Fixed	Comp.	10%	302-101
R481		47 Ω	1/2 w	Fixed	Comp.	10%	302-470
R484		6-30 k	5 w	Fixed	Prec.	1%	310-507
R486		47 Ω	1/2 w	Fixed	Comp.	10%	302-470
R487		39 k	2 w	Fixed	Comp.	10%	306-393
R488		39 k	2 w	Fixed	Comp.	10%	306-393
R490		390 Ω	1/2 w	Fixed	Comp.	10%	302-391
R491		47 Ω	1/2 w	Fixed	Comp.	10%	302-470
R492		2.2 k	1/2 w	Fixed	Comp.	10%	302-222
R494		470 k	1/2 w	Fixed	Comp.	10%	302-474
R495		820 k	1/2 w	Fixed	Comp.	10%	302-824
R496		820 k	1/2 w	Fixed	Comp.	10%	302-824
R497		470 k	1/2 w	Fixed	Comp.	10%	302-474
R506		68 k	2 w	Fixed	Comp.	10%	306-683
R510		1 meg	1/2 w	Fixed	Comp.	10%	302-105
R511		47 Ω	1/2 w	Fixed	Comp.	10%	302-470
R512		100 Ω	1/2 w	Fixed	Comp.	10%	302-101
R513		68 k	2 w	Fixed	Comp.	10%	306-683
R520		68 K	1/2 w	Fixed	Comp.	5%	301-683

## Resistors (continued)

							Tektronix Part Number
R521		1 meg	1/2 w	Fixed	Comp.	5%	301-105
R522		10 k	1/2 w	Fixed	Comp.	10%	302-103
R523		470 k	1/2 w	Fixed	Comp.	10%	302-474
R525		1 k	1/2 w	Fixed	Comp.	10%	302-102
R526		3.3 k	2 w	Fixed	Comp.	10%	306-332
R528		1.8 meg	1/2 w	Fixed	Comp.	10%	302-185
R529		1 meg	1/2 w	Fixed	Comp.	10%	302-105
R530		68 k	1/2 w	Fixed	Comp.	5%	301-683
R531		1 meg	1/2 w	Fixed	Comp.	5%	301-105
R532		10 k	1/2 w	Fixed	Comp.	10%	302-103
R533		470 k	1/2 w	Fixed	Comp.	10%	302-474
R535		1 k	1/2 w	Fixed	Comp.	10%	302-102
R536		3.3 k	2 w	Fixed	Comp.	10%	306-332
R538		1.8 meg	1/2 w	Fixed	Comp.	10%	302-185
R539		1 meg	1/2 w	Fixed	Comp.	10%	302-105
R550		1 meg	1/2 w	Fixed	Comp.	10%	302-105
R551		100 Ω	1/4 w	Fixed	Comp.	10%	316-101
R555		47 k	1/2 w	Fixed	Comp.	10%	302-473
R556		12 k	1/2 w	Fixed	Comp.	10%	302-123
R561		100 Ω	1/2 w	Fixed	Comp.	10%	302-101
R564		10 k	1/2 w	Fixed	Comp.	10%	302-103
R565		100 k	1/2 w	Fixed	Comp.	10%	302-104
R566		47 k	1/2 w	Fixed	Comp.	10%	302-473
R567		100 Ω	1/2 w	Fixed	Comp.	10%	302-101
R568		10 k	1 w	Fixed	Comp.	10%	304-103
R569	X630-up	100 k	1/2 w	Fixed	Comp.	10%	302-104
R571		10 k	5 w	Fixed	WW	5%	308-008
R572		10 k		Var.	WW		311-015
R573		30 k		Var.	Helipot		311-022
R576		2 k		Var.	WW	5%	311-141
R577		15 k	10 w	Fixed	WW	5%	Use 308-024
R581		100 Ω	1/2 w	Fixed	Comp.	10%	302-101
R583		2.7 k	1/2 w	Fixed	Comp.	10%	302-272
R584		95 k	1/2 w	Fixed	Prec.	1%	309-044
R586		150 k	1/2 w	Fixed	Prec.	1%	309-049
R587		39 k	2 w	Fixed	Comp.	10%	306-393
R591		100 Ω	1/2 w	Fixed	Comp.	10%	302-101
R593		3.3 k	1/2 w	Fixed	Comp.	10%	302-332
R594		10 k	1/2 w	Fixed	Comp.	10%	302-103
R595		270 k	1/2 w	Fixed	Comp.	10%	302-274
R596		100 Ω	1/2 w	Fixed	Comp.	10%	302-101
R597		47 Ω	1/2 w	Fixed	Comp.	10%	302-470
R598		1 k	1/2 w	Fixed	Comp.	10%	302-102
R600	101-1319X	12 Ω	1 w	Fixed	Comp.	10%	304-120
R602		50 Ω		Var.	WW		311-055
R608		33 k	1/2 w	Fixed	Comp.	10%	302-333
R610		100 k	1/2 w	Fixed	Comp.	10%	302-104
R615		68 k	1 w	Fixed	Prec.	1%	310-054
R616		10 k		Var.	WW		311-015
R617		50 k	1 w	Fixed	Prec.	1%	310-086
R618		100 k	1/2 w	Fixed	Comp.	10%	302-104

## Resistors (continued)

							Tektronix Part Number
R621	1 k	1/2 w	Fixed	Comp.	10%	302-102	
R623	470 k	1/2 w	Fixed	Comp.	10%	302-474	
R625	100 k	1/2 w	Fixed	Comp.	10%	302-104	
R628	3.3 meg	1/2 w	Fixed	Comp.	10%	302-335	
R629	2.2 meg	1/2 w	Fixed	Comp.	10%	302-225	
R633	1.5 meg	1/2 w	Fixed	Comp.	10%	302-155	
R635	18 k	1 w	Fixed	Comp.	10%	304-183	
R636	12 k	1/2 w	Fixed	Comp.	10%	302-123	
R637	220 k	1/2 w	Fixed	Comp.	10%	302-224	
R638	68 k	1/2 w	Fixed	Comp.	10%	302-683	
R639	150 k	1/2 w	Fixed	Comp.	10%	302-154	
R640	10 $\Omega$	2 w	Fixed	Comp.	10%	306-100	
R641	10 $\Omega$	2 w	Fixed	Comp.	10%	306-100	
R642	150 k	1 w	Fixed	Comp.	10%	304-154	
R643	1 k	1/2 w	Fixed	Comp.	10%	302-102	
R646	1 k	25 w	Fixed	WW	5%	308-037	
R647	1.25 k	25 w	Fixed	WW	5%	308-102	
R650	333 k	1 w	Fixed	Prec.	1%	310-056	
R651	490 k	1 w	Fixed	Prec.	1%	310-057	
R663	1.5 meg	1/2 w	Fixed	Comp.	10%	302-155	
R667	820 k	1/2 w	Fixed	Comp.	10%	302-824	
R668	47 k	1/2 w	Fixed	Comp.	10%	302-473	
R669	39 k	1/2 w	Fixed	Comp.	10%	302-393	
R670	10 $\Omega$	1 w	Fixed	Comp.	10%	304-100	
R671	82 k	1 w	Fixed	Comp.	10%	304-823	
R672	10 $\Omega$	1 w	Fixed	Comp.	10%	304-100	
R673	1 k	1/2 w	Fixed	Comp.	10%	302-102	
R675	400 $\Omega$	20 w	Fixed	WW	5%	308-029	
R677	500 $\Omega$	20 w	Fixed	WW	5%	308-096	
R678	6 k	5 w	Fixed	WW	5%	308-052	
R680	333 k	1 w	Fixed	Prec.	1%	310-056	
R681	220 k	1 w	Fixed	Prec.	1%	310-055	
R682	120 k	1/2 w	Fixed	Comp.	10%	302-124	
R683	1 k	1/2 w	Fixed	Comp.	10%	302-102	
R685	82 k	1/2 w	Fixed	Comp.	10%	302-823	
R686	180 k	1/2 w	Fixed	Comp.	10%	302-184	
R688	1.5 meg	1/2 w	Fixed	Comp.	10%	302-155	
R689	2.2 meg	1/2 w	Fixed	Comp.	10%	302-225	
P693	1.5 meg	1/2 w	Fixed	Comp.	10%	302-155	
R697	1.2 meg	1/2 w	Fixed	Comp.	10%	302-125	
R698	270 k	1/2 w	Fixed	Comp.	10%	302-274	
R699	56 k	1/2 w	Fixed	Comp.	10%	302-563	
R700	10 $\Omega$	2 w	Fixed	Comp.	10%	306-100	
R701	10 $\Omega$	2 w	Fixed	Comp.	10%	306-100	
R702	220 k	1 w	Fixed	Comp.	10%	304-224	
R703	1 k	1/2 w	Fixed	Comp.	10%	302-102	
R704	1 k	1/2 w	Fixed	Comp.	10%	302-102	
R707	750 $\Omega$	25 w	Fixed	WW	5%	308-147	
R710	237 k	1 w	Fixed	Prec.	1%	Use 310-124	
R711	100 k	1/2 w	Fixed	Prec.	1%	Use 309-334	

## Resistors (continued)

Tektronix  
Part Number

R712		150 k	1/2 w	Fixed	Comp.	10%	302-154
R717		100 k	1/2 w	Fixed	Comp.	10%	302-104
R723		1.5 meg	1/2 w	Fixed	Comp.	10%	302-155
R727		1 meg	1/2 w	Fixed	Comp.	10%	302-105
R728		560 k	1/2 w	Fixed	Comp.	10%	302-564
R729		47 k	1/2 w	Fixed	Comp.	10%	302-473
R730		18 Ω	2 w	Fixed	Comp.	10%	306-180
R731		18 Ω	2 w	Fixed	Comp.	10%	306-180
R732		220 k	1 w	Fixed	Comp.	10%	304-224
R733		18 Ω	2 w	Fixed	Comp.	10%	306-180
R734		1 k	1/2 w	Fixed	Comp.	10%	302-102
R735		1 k	1/2 w	Fixed	Comp.	10%	302-102
R736		1.25 k	25 w	Fixed	WW	5%	308-102
R737		1.25 k	25 w	Fixed	WW	5%	308-102
R738		1.25 k	25 w	Fixed	WW	5%	308-102
R740		220 k	1 w	Fixed	Prec.	1%	310-055
R741		720 k	1 w	Fixed	Prec.	1%	310-059
R753		1 meg	1/2 w	Fixed	Comp.	10%	302-105
R757		150 k	1/2 w	Fixed	Comp.	10%	302-154
R758		120 k	1/2 w	Fixed	Comp.	10%	302-124
R759		27 k	1/2 w	Fixed	Comp.	10%	302-273
R760		10 Ω	1 w	Fixed	Comp.	10%	304-100
R761		150 k	1 w	Fixed	Comp.	10%	304-154
R762		82 k	1 w	Fixed	Comp.	10%	304-823
R763		1 k	1/2 w	Fixed	Comp.	10%	302-102
R767		1.5 k	10 w	Fixed	WW	5%	308-055
R775		220 Ω	2 w	Fixed	Comp.	10%	306-221
R776		47 Ω	1/2 w	Fixed	Comp.	10%	302-470
R778		47 Ω	1/2 w	Fixed	Comp.	10%	302-470
R781		100 k	1/2 w	Fixed	Comp.	10%	302-104
R784		1 k	1/2 w	Fixed	Comp.	10%	302-102
R790		100 k	1/2 w	Fixed	Comp.	10%	302-104
R791		1 k	1/2 w	Fixed	Comp.	10%	302-102
R792	X1320-up	4.7 meg	1/2 w	Fixed	Comp.	10%	302-475
R793		470 k	1/2 w	Fixed	Comp.	10%	302-474
R794	101-1319	18 k	1/2 w	Fixed	Comp.	10%	302-183
R794	1320-up	9.7 k	1/2 w	Fixed	Prec.	1%	309-226
R795	X1320-up	5.6 meg	1/2 w	Fixed	Comp.	10%	302-565
R796		1.8 meg	1/2 w	Fixed	Comp.	10%	302-185
R798	101-539	4.7 Ω	1 w	Fixed	Comp.	10%	307-009
R798	540-up	10 Ω	1 w	Fixed	Comp.	10%	304-100
R799		10 Ω		Var.	WW		311-001
R803		82 k	2 w	Fixed	Comp.	10%	Use 306-823
R806		47 k	1/2 w	Fixed	Comp.	10%	302-473
R807		1.5 k	1/2 w	Fixed	Comp.	10%	302-152
R814		470 k	1/2 w	Fixed	Comp.	10%	302-474
R818	X1440-up	1.2 meg	1/2 w	Fixed	Comp.	10%	302-125
R819	X1440-up	2.2 meg	1/2 w	Fixed	Comp.	10%	302-225
R820		47 k	1/2 w	Fixed	Comp.	10%	302-473
R824		4.7 meg	1/2 w	Fixed	Comp.	10%	302-475
R825		4.7 meg	1/2 w	Fixed	Comp.	10%	302-475
R826		1 meg		Var.	Comp.		311-041
R827		27 k	1/2 w	Fixed	Comp.	10%	302-273
R828		1 meg	1/2 w	Fixed	Comp.	10%	302-105
R844		10 k	1/2 w	Fixed	Comp.	10%	302-103
R847		27 k	1/2 w	Fixed	Comp.	10%	302-273

## Resistors (continued)

							Tektronix Part Number
R848		1 meg	1/2 w	Fixed	Comp.	10%	302-105
R850		820 k	1/2 w	Fixed	Comp.	10%	302-824
R852		1 meg		Var.	Comp.		311-039
R853		1.5 meg	1/2 w	Fixed	Comp.	10%	302-155
R854		1.5 meg	1/2 w	Fixed	Comp.	10%	302-155
R856		2 meg		Var.	Comp.		311-043
R857		1 meg	1/2 w	Fixed	Comp.	10%	302-105
R861		100 k		Var.	Comp.		311-026
R862	101-995X	150 k	1/2 w	Fixed	Comp.	10%	302-154
R863	101-995	56 k	1/2 w	Fixed	Comp.		302-563
R863	996-up	200 k	.2 w	Var.	Comp.		311-219
R864		100 k		Var.	Comp.		311-026
R870		150 k	1/2 w	Fixed	Comp.	10%	302-154
R871		2.7 meg	1/2 w	Fixed	Comp.	10%	302-275
R872		1 k	1/2 w	Fixed	Comp.	10%	302-102
R874		3.9 meg	1/2 w	Fixed	Comp.	10%	302-395
R875		68 k	1/2 w	Fixed	Comp.	10%	302-683
R876		1 k	1/2 w	Fixed	Comp.	10%	302-102
R878		33 k	1 w	Fixed	Comp.	10%	304-333
R879		10 k		Var.	Comp.		311-016
R880		100 k	1/2 w	Fixed	Comp.	10%	302-104
R883		100 $\Omega$	1/2 w	Fixed	Comp.	10%	302-101
R885		9.5 k	1/2 w	Fixed	Prec.	1%	309-121
R886		6.375 k	1/2 w	Fixed	Prec.	1%	309-119
R887		2.1 k	1/2 w	Fixed	Prec.	1%	309-117
R888		1.025 k	1/2 w	Fixed	Prec.	1%	309-116
R889		610 $\Omega$	1/2 w	Fixed	Prec.	1%	309-113
R890		200 $\Omega$	1/2 w	Fixed	Prec.	1%	309-073
R891		100 $\Omega$	1/2 w	Fixed	Prec.	1%	309-112
R892		60 $\Omega$	1/2 w	Fixed	Prec.	1%	309-067
R893		40 $\Omega$	1/2 w	Fixed	Prec.	1%	309-066
R896		100 k	1/2 w	Fixed	Prec.	1%	309-045
R897		100 $\Omega$	1/2 w	Fixed	Prec.	1%	309-112
R898		100 $\Omega$	1/2 w	Fixed	Comp.	10%	302-101
R899		1/4 $\Omega$	1 w	Fixed	WW	10%	308-090
R903	101-169	47 k	1 w	Fixed	Comp.	10%	304-473
R903	170-up	30 k	10 w	Fixed	WW	5%	308-027
R906		47 k	1/2 w	Fixed	Comp.	10%	302-473
R907		1.5 k	1/2 w	Fixed	Comp.	10%	302-152
R914		470 k	1/2 w	Fixed	Comp.	10%	302-474
R918	X1440-up	1.8 meg	1/2 w	Fixed	Comp.	10%	302-185
R919	X1440-up	1.8 meg	1/2 w	Fixed	Comp.	10%	302-185
R920		47 k	1/4 w	Fixed	Comp.	10%	316-473
R924		4.7 meg	1/2 w	Fixed	Comp.	10%	302-475
R925		4.7 meg	1/2 w	Fixed	Comp.	10%	302-475
R926		1 meg		Var.	Comp.		311-041
R927		33 k	1/2 w	Fixed	Comp.	10%	302-333
R928		1 meg	1/2 w	Fixed	Comp.	10%	302-105
R935		1 meg	1/4 w	Fixed	Comp.	10%	316-105
R944		10 k	1/4 w	Fixed	Comp.	10%	316-103
R947		27 k	1/2 w	Fixed	Comp.	10%	302-273
R948		1 meg	1/2 w	Fixed	Comp.	10%	302-105
R950		820 k	1/2 w	Fixed	Comp.	10%	302-824
R952		1 meg		Var.	Comp.		311-039

## Resistors (continued)

							Tektronix Part Number
R953		1.5 meg	1/2 w	Fixed	Comp.	10%	302-155
R954		1.5 meg	1/2 w	Fixed	Comp.	10%	302-155
R956		2 meg		Var.	Comp.		311-043
R957		1 meg	1/2 w	Fixed	Comp.	10%	302-105
R961		100 k		Var.	Comp.		311-026
R964		100 k		Var.	Comp.		311-026
R973		20 k		Var.	WW		311-151
R974		2 k	5 w	Fixed	WW	5%	308-091
R975		5 k	5 w	Fixed	WW	5%	308-135
R1003		100 Ω	1 w	Fixed	Comp.	10%	304-101
R1005		100 Ω	1 w	Fixed	Comp.	10%	304-101
R1007		47 Ω	1/2 w	Fixed	Comp.	10%	302-470
R1008		47 Ω	1/2 w	Fixed	Comp.	10%	302-470
R1009		100 Ω	1 w	Fixed	Comp.	10%	304-101
R1011		27 Ω	1/2 w	Fixed	Comp.	10%	302-270
R1013		910 Ω	2 w	Fixed	Comp.	5%	305-911
R1014		500 Ω	1/2 w	Fixed	Prec.	1%	309-179
R1016		3 k	5 w	Fixed	WW	5%	308-062
R1017		10 k	8 w	Fixed	WW	5%	308-126
R1018		330 Ω	1/2 w	Fixed	Comp.	10%	302-331
R1019		470 k	1/2 w	Fixed	Comp.	10%	302-474
R1021		27 Ω	1/2 w	Fixed	Comp.	10%	302-270
R1024		500 Ω	1/2 w	Fixed	Prec.	1%	309-179
R1026		330 Ω	1/2 w	Fixed	Comp.	10%	302-331
R1027		200 Ω		Var.	Comp.		Use 311-333
R1029		470 k	1/2 w	Fixed	Comp.	10%	302-474
R1031		2.2 k	1 w	Fixed	Comp.	10%	304-222
R1033		2.5 k	5 w	Fixed	WW	5%	308-127
R1036		27 k	2 w	Fixed	Comp.	10%	306-273
R1039		33 Ω	1/2 w	Fixed	Comp.	10%	302-330
R1046		27 k	2 w	Fixed	Comp.	10%	306-273
R1049		33 Ω	1/2 w	Fixed	Comp.	10%	302-330
R1052		470 k	1/2 w	Fixed	Comp.	10%	302-474
R1053	101-219X	50 Ω		Var.	WW		311-055
R1054		167 Ω	5 w	Fixed	WW	5%	308-104
R1055		4.5 k	5 w	Fixed	WW	5%	308-066
R1062		470 k	1/2 w	Fixed	Comp.	10%	302-474
R1071	}	600 Ω	5 w	Fixed	Checked	1/2% of each other	312-587
R1073							
R1075							
R1077		47 Ω	1/4 w	Fixed	Comp.	10%	316-470
R1078		150 Ω	1/4 w	Fixed	Comp.	10%	316-151
R1080		120 k	1/2 w	Fixed	Comp.	10%	302-124
R1081		330 k	1/2 w	Fixed	Comp.	10%	302-334
R1083		390 k	1/2 w	Fixed	Comp.	10%	302-394
R1084		680 k	1/2 w	Fixed	Comp.	10%	302-684
R1085		1 meg	1/4 w	Fixed	Comp.	10%	316-105
R1090	101-1554	8.2 k	Selected				316-822
R1090	1555-up	6.8 k	Selected				316-682
R1091		250 k		Var.	Comp.	20%	311-061
R1092		47 k	1/2 w	Fixed	Comp.	10%	302-473
R1093	X1740-up	56 k	1 w	Fixed	Comp.	10%	304-563

## Resistors (continued)

							Tektronix Part Number
R1094	101-1554 1555-up	68 k	1/10 w	Fixed	IRC	10%	307-006
R1095		8.2 k	Selected				316-822
R1095		6.8 k	Selected				316-682
R1097		47 k	1/2 w	Fixed	Comp.	10%	302-473
R1099		68 k	1/10 w	Fixed	IRC	10%	307-006
R1102		470 k	1/2 w	Fixed	Comp.	10%	302-474
R1105		4.5 k	5 w	Fixed	WW	5%	308-066
R1112		470 k	1/2 w	Fixed	Comp.	10%	302-474
R1122		470 k	1/2 w	Fixed	Comp.	10%	302-474
R1125		4.5 k	5 w	Fixed	WW	5%	308-066
R1132		470 k	1/2 w	Fixed	Comp.	10%	302-474
R1142		470 k	1/2 w	Fixed	Comp.	10%	302-474
R1145		4.5 k	5 w	Fixed	WW	5%	308-066
R1152		470 k	1/2 w	Fixed	Comp.	10%	302-474
R1162		470 k	1/2 w	Fixed	Comp.	10%	302-474
R1165		4.5 k	5 w	Fixed	WW	5%	308-066
R1172		470 k	1/2 w	Fixed	Comp.	10%	302-474
R1182		470 k	1/2 w	Fixed	Comp.	10%	302-474
R1185		4.5 k	5 w	Fixed	WW	5%	308-066
R1192		470 k	1/2 w	Fixed	Comp.	10%	302-474
R1202		470 k	1/2 w	Fixed	Comp.	10%	302-474
R1205		4.5 k	5 w	Fixed	WW	5%	308-066
R1206		360 $\Omega$	1/2 w	Fixed	Comp.	5%	301-361
R1208		12 k	8 w	Fixed	WW	5%	308-069
R1212		470 k	1/2 w	Fixed	Comp.	10%	302-474
R1216		360 $\Omega$	1/2 w	Fixed	Comp.	5%	301-361
R1218		1 k	5 w	Fixed	WW	5%	308-106
R1221		100 $\Omega$	1/2 w	Fixed	Comp.	10%	302-101
R1223		4.7 k	2 w	Fixed	Comp.	10%	306-472
R1224		30 k	10 w	Fixed	WW	5%	308-027
R1227		390 k	1/2 w	Fixed	Comp.	10%	302-394
R1228		1 meg	1/4 w	Fixed	Comp.	10%	316-105
R1301		1 k	1/2 w	Fixed	Comp.	10%	302-102
R1302		1 k	1/2 w	Fixed	Comp.	10%	302-102
R1303		1 k	1/2 w	Fixed	Comp.	10%	302-102
R1304		1 k	1/2 w	Fixed	Comp.	10%	302-102
R1305		1 k	1/2 w	Fixed	Comp.	10%	302-102
R1306		1 k	1/2 w	Fixed	Comp.	10%	302-102
R1307		1 k	1/2 w	Fixed	Comp.	10%	302-102
R1308		1 k	1/2 w	Fixed	Comp.	10%	302-102
R1424		150 k	1/2 w	Fixed	Comp.	10%	302-154
R1484		100 k	1/2 w	Fixed	Comp.	10%	302-104
R2003		100 $\Omega$	1 w	Fixed	Comp.	10%	304-101
R2005		100 $\Omega$	1 w	Fixed	Comp.	10%	304-101
R2007		47 $\Omega$	1/2 w	Fixed	Comp.	10%	302-470
R2008		47 $\Omega$	1/2 w	Fixed	Comp.	10%	302-470
R2009		100 $\Omega$	1 w	Fixed	Comp.	10%	304-101
R2011		27 $\Omega$	1/2 w	Fixed	Comp.	10%	302-270
R2013		910 $\Omega$	2 w	Fixed	Comp.	5%	305-911
R2014		500 $\Omega$	1/2 w	Fixed	Prec.	1%	309-179
R2016		3 k	5 w	Fixed	WW	5%	308-062

## Resistors (continued)

							Tektronix Part Number
R2017		10 k	8 w	Fixed	WW	5%	308-126
R2018		330 Ω	1/2 w	Fixed	Comp.	10%	302-331
R2019		470 k	1/2 w	Fixed	Comp.	10%	302-474
R2021		27 Ω	1/2 w	Fixed	Comp.	10%	302-270
R2024		500 Ω	1/2 w	Fixed	Prec.	1%	309-179
R2026		330 Ω	1/2 w	Fixed	Comp.	10%	302-331
R2027		200 Ω		Var.	Comp.		Use 311-333
R2029		470 k	1/2 w	Fixed	Comp.	10%	302-474
R2031		2.2 k	1 w	Fixed	Comp.	10%	304-222
R2033		2.5 k	5 w	Fixed	WW	5%	308-127
R2036		27 k	2 w	Fixed	Comp.	10%	306-273
R2039		33 Ω	1/2 w	Fixed	Comp.	10%	302-330
R2046		27 k	2 w	Fixed	Comp.	10%	306-273
R2049		33 Ω	1/2 w	Fixed	Comp.	10%	302-330
R2052		470 k	1/2 w	Fixed	Comp.	10%	302-474
R2054		167 Ω	5 w	Fixed	WW	5%	308-104
R2055		4.5 k	5 w	Fixed	WW	5%	308-066
R2062		470 k	1/2 w	Fixed	Comp.	10%	302-474
R2071	}	600 Ω	5 w	Fixed	Checked	1/2 % of each other	312-587
R2073							
R2075		220 Ω	1/4 w	Fixed	Comp.	10%	316-221
R2077		47 Ω	1/4 w	Fixed	Comp.	10%	316-470
R2078		150 Ω	1/4 w	Fixed	Comp.	10%	316-151
R2080	X990-up	120 k	1/2 w	Fixed	Comp.	10%	302-124
R2081	X990-up	330 k	1/2 w	Fixed	Comp.	10%	302-334
R2083		390 k	1/2 w	Fixed	Comp.	10%	302-394
R2084		680 k	1/2 w	Fixed	Comp.	10%	302-684
R2085		1 meg	1/4 w	Fixed	Comp.	10%	316-105
R2090	101-1554	8.2 k	Selected				316-822
R2090	1555-up	6.8 k	Selected				316-682
R2091		250 k		Var.	Comp.		311-061
R2092		47 k	1/2 w	Fixed	Comp.	10%	302-473
R2093	X1740-up	56 k	1 w	Fixed	Comp.	10%	304-563
R2094		68 k	1/10 w	Fixed	IRC	10%	307-006
R2095	101-1554	8.2 k	Selected				316-822
R2095	1555-up	6.8 k	Selected				316-682
R2097		47 k	1/2 w	Fixed	Comp.	10%	302-473
R2099		68 k	1/10 w	Fixed	IRC	10%	307-006
R2102		470 k	1/2 w	Fixed	Comp.	10%	302-474
R2105		4.5 k	5 w	Fixed	WW	5%	308-066
R2112		470 k	1/2 w	Fixed	Comp.	10%	302-474
R2122		470 k	1/2 w	Fixed	Comp.	10%	302-474
R2125		4.5 k	5 w	Fixed	WW	5%	308-066
R2132		470 k	1/2 w	Fixed	Comp.	10%	302-474
R2142		470 k	1/2 w	Fixed	Comp.	10%	302-474
R2145		4.5 k	5 w	Fixed	WW	5%	308-066
R2152		470 k	1/2 w	Fixed	Comp.	10%	302-474
R2162		470 k	1/2 w	Fixed	Comp.	10%	302-474
R2165		4.5 k	5 w	Fixed	WW	5%	308-066
R2172		470 k	1/2 w	Fixed	Comp.	10%	302-474
R2182		470 k	1/2 w	Fixed	Comp.	10%	302-474
R2185		4.5 k	5 w	Fixed	WW	5%	308-066
R2192		470 k	1/2 w	Fixed	Comp.	10%	302-474
R2202		470 k	1/2 w	Fixed	Comp.	10%	302-474
R2205		4.5 k	5 w	Fixed	WW	5%	308-066

### Resistors (continued)

							Tektronix Part Number
R2206	360 Ω	1/2 w	Fixed	Comp.	5%	301-361	
R2208	12 k	8 w	Fixed	WW	5%	308-069	
R2212	470 k	1/2 w	Fixed	Comp.	10%	302-474	
R2216	360 Ω	1/2 w	Fixed	Comp.	5%	301-361	
R2218	1 k	5 w	Fixed	WW	5%	308-106	
R2221	100 Ω	1/2 w	Fixed	Comp.	10%	302-101	
R2223	4.7 k	2 w	Fixed	Comp.	10%	306-472	
R2224	30 k	10 w	Fixed	WW	5%	308-027	
R2227	390 k	1/2 w	Fixed	Comp.	10%	302-394	
R2228	1 meg	1/4 w	Fixed	Comp.	10%	316-105	
R2301	1 k	1/2 w	Fixed	Comp.	10%	302-102	
R2302	1 k	1/2 w	Fixed	Comp.	10%	302-102	
R2303	1 k	1/2 w	Fixed	Comp.	10%	302-102	
R2304	1 k	1/2 w	Fixed	Comp.	10%	302-102	
R2305	1 k	1/2 w	Fixed	Comp.	10%	302-102	
R2306	1 k	1/2 w	Fixed	Comp.	10%	302-102	
R2307	1 k	1/2 w	Fixed	Comp.	10%	302-102	
R2308	1 k	1/2 w	Fixed	Comp.	10%	302-102	
R2423	100 k	1/2 w	Fixed	Comp.	10%	302-104	
R2424	150 k	1/2 w	Fixed	Comp.	10%	302-154	

### Switches

		unwired	wired
SW332	Display Switch	260-270	262-215
SW350	Left Horiz. Display Switch	260-269	262-213
SW432	Display switch	260-270	262-216
SW450	Right Horiz. Display Switch	260-269	262-214
SW601	Power On	260-276	
SW848	CRT Cathode Selector Switch, Upper Beam	260-209	
SW870	Calibrator Switch	260-253	262-212
SW948	CRT Cathode Selector Switch, Lower Beam	260-209	

### Transformers

T601	Plate Transformer	*120-128
T602	Filament Transformer (Power Supply)	*120-127
T750	Filament Transformer (Indicator)	*120-122
T801	H.V. Left	*120-123
T901	H.V. Right	*120-124

### Thermal Cutouts

TK601	133° Thermo Cutout	260-208
TK750	133° Thermo Cutout	260-208

## Vacuum Tubes

		Tektronix Part Number
V314	ECC88/6DJ8	154-187
V343	ECC88/6DJ8	154-187
V364	ECC88/6DJ8	154-187
V384	ECC88/6DJ8	154-187
V398	6CL6	154-031
V414	ECC88/6DJ8	154-187
V443	ECC88/6DJ8	154-187
V464	ECC88/6DJ8	154-187
V484	ECC88/6DJ8	154-187
V498	6CL6	154-031
V513	6AU6	154-022
V524	ECC88/6DJ8	154-187
V534	ECC88/6DJ8	154-187
V554	6AU6	154-022
V564	6AU6	154-022
V568	ECC88/6DJ8	154-187
V585	ECC88/6DJ8	154-187
V609	5651	154-052
V624	12AX7	154-043
V634	6AU6	154-022
V647	6080	154-056
V664	6AU6	154-022
V677	6080	154-056
V684	12AX7	154-043
V694	6AU6	154-022
V707	6080	154-056
V724	6AU6	154-022
V727	6080	154-056
V737	6080	154-056
V754	6AU6	154-022
V757	12B4	154-044
V767	12B4	154-044
V794	6CZ5	154-167
V799	2 AS-15	154-006
V800	6CZ5	154-167
V814	12AU7	154-041
V859	T5550-2 CRT Standard Phosphor	*154-199
V862	5642	154-051
V875	6AU6	154-022
V822	5642	154-051
V885	12AU7	154-041
V900	6CZ5	154-167
V914	12AU7	154-041
V922	5642	154-051
V932	5642	154-051
V942	5642	154-051
V962	5642	154-051
V1014*	12BY7 Selected	*157-053
V1024*	12BY7 Selected	*157-053
V1033	ECC88/6DJ8	154-187

\*V1014 and V1024 furnished as a unit.

Vacuum Tubes (continued)

		Tektronix Part Number
V1043	ECC88/6DJ8	154-187
V1054	8136	Use 154-367
V1064	8136	Use 154-367
V1084	ECC88/6DJ8	154-187
V1104	8136	Use 154-367
V1114	8136	Use 154-367
V1124	8136	Use 154-367
V1134	8136	Use 154-367
V1144	8136	Use 154-367
V1154	8136	Use 154-367
V1164	8136	Use 154-367
V1174	8136	Use 154-367
V1184	8136	Use 154-367
V1194	8136	Use 154-367
V1204	8136	Use 154-367
V1214	8136	Use 154-367
V1223	ECC88/6DJ8	154-187
V2014**	12BY7 Selected	*157-053
V2024**	12BY7 Selected	*157-053
V2033	ECC88/6DJ8	154-187
V2043	ECC88/6DJ8	154-187
V2054	8136	Use 154-367
V2064	8136	Use 154-367
V2104	8136	Use 154-367
V2114	8136	Use 154-367
V2124	8136	Use 154-367
V2134	8136	Use 154-367
V2144	8136	Use 154-367
V2154	8136	Use 154-367
V2164	8136	Use 154-367
V2174	8136	Use 154-367
V2184	8136	Use 154-367
V2194	8136	Use 154-367
V2204	8136	Use 154-367
V2214	8136	Use 154-367
V2223	ECC88/6DJ8	154-187

\*\*V2014 and V2024 furnished as a unit.

# Type 555 Mechanical Parts List

	Tektronix Part Number
ADAPTER, BINDING POST      SN 101-4939	013-004
ADAPTER, BINDING POST      SN 4940-up	103-033
ANGLE, FRAME, BOTTOM, BLUE WRINKLE      SN 101-599	122-039
ANGLE, FRAME, BOTTOM, BLUE VINYL      SN 600-up	122-072
ANGLE, FRAME, POWER, BOTTOM, BLUE WRINKLE      SN 101-599	122-042
ANGLE, FRAME, POWER, BOTTOM, BLUE VINYL      SN 600-up	122-067
ANGLE, FRAME, POWER TOP	122-043
ANGLE, BRACE, TIME BASE      SN 101-339	122-058
ANGLE, BRACE, TIME BASE, RIGHT      SN 340-up	122-082
ANGLE, BRACE, TIME BASE, LEFT      SN 340-up	122-083
BAR, $\frac{3}{16} \times \frac{1}{2} \times 1\frac{3}{4}$ W/2 8-32 HOLES	381-073
BAR, TOP WITH HANDLE (POWER) BLUE VINYL	use 381-207
BAR, TOP, CHANNEL, BLUE VINYL (INDICATOR)	use 381-210
BOLT, SPADE, 6-32 x $\frac{7}{8}$	214-013
BOLT, CAPTIVE, $\frac{3}{8} \times 1\frac{1}{16}$	214-074
BRACKET, SPRING, PHOS. BRONZE, CRT SPRING	406-239
BRACKET, NYLON, $.160 \times \frac{3}{4} \times 1\frac{3}{8}$	406-244
BRACKET, PHOS. BRONZE, $\frac{3}{4} \times \frac{1}{2} \times 1\frac{5}{16}$	406-245
BRACKET, TRANSFORMER SUPPORT, $.080 \times 4 \times 4 \times \frac{5}{8}$	406-294
BRACKET, CRT SUPPORT	406-455
BRACKET, 5 POT	406-456
BRACKET, LEFT MAG.	406-457
BRACKET, RIGHT MAG.	406-458
BRACKET, ALUM. $.051 \times 4\frac{1}{2} \times \frac{3}{4}$	406-464
BRACKET, POT, $.080 \times 1 \times 1\frac{1}{2} \times \frac{1}{2}$ (R852)	406-465
BRACKET, POT, $.080 \times 1 \times 1\frac{1}{2} \times \frac{1}{2}$ (R952)	406-466
BRACKET, MINI POT      SN 996-up	406-576
BRACKET, SUPPORT TRANSFORMER, $.080 \times \frac{3}{4} \times 2\frac{25}{32} \times 2\frac{1}{2}$ SN 347-up	406-590
BUSHING, NYLON FOR 5-WAY BINDING POST	358-036
CABLE, HARNESS, V.A. "A"      SN 101-219	179-161
CABLE, HARNESS, V.A. "B"      SN 101-219	179-194

**Mechanical Parts List (continued)**

	Tektronix Part Number
CABLE, HARNESS, V.A. "A" SN 220-up	179-378
CABLE, HARNESS, V.A. "B" SN 220-up	179-379
CABLE, HARNESS, BULKHEAD	179-307
CABLE, HARNESS, RIGHT HORIZ. AMP.	Use 179-558
CABLE, HARNESS, LEFT HORIZ. AMP.	Use 179-559
CABLE, HARNESS, DELAY PICK-OFF	179-310
CABLE, HARNESS, EXTERNAL AMP.	179-311
CABLE, HARNESS, 100 V INDICATOR	179-313
CABLE, HARNESS, POWER SN 101-1319	179-326
CABLE, HARNESS, POWER SN 1320-up	179-546
CABLE, HARNESS, 110 V POWER	179-327
CABLE, HARNESS, DELAY PICK-OFF	179-365
CABLE, HARNESS, CRT SOCKET	179-870
CAP, FUSE	200-015
CAP, BINDING POST	200-182
CHASSIS, DELAY LINE, HORIZ.	441-114
CHASSIS, DELAY LINE, VERT.	441-115
CHASSIS, VERT. AMP.	441-168
CHASSIS, HORIZ. AMP. & H.V., LEFT SIDE	441-235
CHASSIS, HORIZ. AMP. & H.V., RIGHT SIDE	441-236
CHASSIS, EXT. AMP.	441-245
CHASSIS, DELAY PICK-OFF	441-246
CHASSIS, DELAY LINE HORIZ. 10" RIGHT SIDE	441-247
CHASSIS, DELAY LINE VERT., 13 <sup>3</sup> / <sub>8</sub> RIGHT SIDE	441-248
CHASSIS, DELAY LINE HORIZ., 8 <sup>1</sup> / <sub>2</sub> " RIGHT SIDE	441-249
CHASSIS, DELAY LINE VERT., 12 <sup>1</sup> / <sub>2</sub> ", RIGHT SIDE	441-250
CHASSIS, POWER SUPPLY	441-252
CHASSIS, DELAY LINE 10", HORIZ., LEFT	441-263
CHASSIS, DELAY LINE 13 <sup>1</sup> / <sub>4</sub> ", VERT., LEFT	441-264
CLAMP, CABLE, <sup>3</sup> / <sub>16</sub> , PLASTIC	343-002
CLAMP, CABLE, <sup>1</sup> / <sub>4</sub> , PLASTIC	343-003
CLAMP, CABLE, <sup>7</sup> / <sub>16</sub> , PLASTIC	343-005
CLAMP, CABLE, <sup>5</sup> / <sub>16</sub> , PLASTIC	343-004
CLAMP, CABLE, <sup>1</sup> / <sub>2</sub> , PLASTIC	343-006

Mechanical Parts List (continued)

	Tektronix Part Number
CLAMP, CABLE, 3/8, PLASTIC	343-013
CLAMP, CABLE, 1, PLASTIC	343-014
CLAMP, #20 WIRE FOR NEON BULBS SN 1320-up	343-043
CLAMP, CRT, STAINLESS STEEL	343-047
CLAMP, CABLE, POLY, 2 3/16	343-049
CLIP, SPRING BRONZE SN 340-up	344-028
CONNECTOR, TIME BASE EXTENSION	013-013
CONNECTOR, CHASSIS MOUNTED, 16 CONTACT, FEMALE	131-018
CONNECTOR, CABLE, CRT PIN	131-049
CONNECTOR, CHASSIS MOUNTED, COAX (CAL-OUT) SN 101-4939	131-064
CONNECTOR, CHASSIS MOUNTED (CAL-OUT) BNC 4940-up	131-279
CONNECTOR, CHASSIS MOUNTED, 16 CONTACT, MALE	131-077
CONNECTOR, CHASSIS MOUNTED, 16 CONTACT, FEMALE SOCKET	131-078
CONNECTOR, COAX, 1 CONTACT, FEMALE, UHF SN 101-4939	131-081
CONNECTOR, COAX, (CONTACT) BNC 4940-up	131-126
CONNECTOR, CHASSIS MOUNTED, 32 CONTACT, MALE	131-096
CONNECTOR, CABLE, 14" ANODE ASS'Y	131-107
CONNECTOR, CHASSIS MOUNTED, 3 WIRE MOTOR BASE ASS'Y	131-150
CORD, POWER	161-010
COUPLING, 1" W/2 TAPPED HOLES	376-007
COUPLING, POT	376-014
COVER, GRATICULE	Use 200-382
COVER, CRT ANODE & PLATE ASS'Y	200-112
DIAL, DUODIAL	331-022
EYELET, TAPERED BARREL	210-601
FAN, BLADE, 7", INDICATOR	369-007
FAN, BLADE, 5 1/2", POWER	369-001
FASTENER, SNAP DOUBLE PRONG, DELRIN	214-153
FILTER, AIR 10 x 10 x 1 (INDICATOR) SN 101-4859	378-011
FILTER, AIR 10 3/8 x 10 3/8 (INDICATOR) SN 4860-up	387-023
FILTER, AIR 7 x 7 x 1 (POWER)	378-015
FILTER, LIGHT, 5" GREEN	378-514
FILTER, SCREEN SN X4860-up	387-762
FOOT, NYLON	348-023
GRATICULE, 5"	331-045
GROMMET, RUBBER 1/4	348-002
GROMMET, RUBBER 5/16	348-003
GROMMET, RUBBER 3/8	348-004
GROMMET, RUBBER 1/2	348-005
GROMMET, RUBBER 3/4	348-006
GROMMET, RUBBER 5/8	348-012

**Mechanical Parts List (continued)**

	Tektronix Part Number
HOLDER, NEON BULB, DOUBLE	352-006
HOLDER, FUSE	352-010
HOLDER, NYLON, FOR COIL FORM W/O PIN	352-016
HOLDER, NYLON, FOR COIL FORM W/PIN	352-017
HOUSING, AIR FILTER, BLUE WRINKLE (INDICATOR) SN 101-599	380-008
HOUSING, AIR FILTER, BLUE VINYL (INDICATOR) SN 600-up	380-018
HOUSING, AIR FILTER, BLUE WRINKLE (POWER) SN 101-599	380-009
HOUSING, AIR FILTER, BLUE VINYL (POWER) SN 600-up	380-016
JEWEL, PILOT LIGHT	378-518
KNOB, SMALL RED, 1/8 HOLE PART WAY	366-031
KNOB, SMALL BLACK, 1/4 HOLE PART WAY	366-033
KNOB, LARGE BLACK, 17/64 HOLE THRU	366-040
KNOB, LARGE BLACK, 1/4 HOLE PART WAY	366-060
LOCKWASHER, EXT. #2	210-002
LOCKWASHER, INT. #4	210-004
LOCKWASHER, INT. #6	210-006
LOCKWASHER, EXT. #8	210-007
LOCKWASHER, INT. #8	210-008
LOCKWASHER, INT. #10	210-010
LOCKWASHER, INT., 1/4	210-011
LOCKWASHER, INT., POT, 3/8 x 1/2	210-012
LOCKWASHER, INT., 3/8 x 11/16	210-013
LOCKWASHER, INT., 1/4	210-046
LUG, SOLDER, SE4	210-201
LUG, SOLDER, SE6, W/2 WIRE HOLES	210-202
LUG, SOLDER, SE6, LONG	210-203
LUG, SOLDER, DE6	210-204
LUG, SOLDER, SE8	210-205
LUG, SOLDER, SE10, LONG	210-206
LUG, SOLDER, POT, PLAIN, 3/8	210-207
LUG, SOLDER, SE8, LONG	210-228
MOTOR, FAN INDICATOR	147-001
MOTOR, FAN, POWER	147-021
MOUNT, FAN 7"	426-047
MOUNT, CRT 3"	426-075

**Mechanical Parts List (continued)**

	Tektronix Part Number
NUT, HEX, CAP, 8-32 x 5/16	210-402
NUT, HEX, 2-56 x 3/16	210-405
NUT, HEX, 4-40 x 3/16	210-406
NUT, HEX, 6-32 x 1/4	210-407
NUT, HEX, 8-32 x 5/16	210-409
NUT, HEX, 10-32 x 5/16	210-410
NUT, HEX, 3/8-32 x 1/2	210-413
NUT, HEX, 15/32-32 x 9/16	210-414
NUT, HEX, 10-24 x 3/8	210-415
NUT, KNURLED, GRATICULE, 3/8-24 x 9/16 x 3/16	210-424
NUT, HEX, 3/8-32 x 1/2 x 5/8	210-444
NUT, HEX, 1/4-28 x 3/8 x 3/32	210-455
NUT, KEPS, 6-32 x 5/16	210-457
NUT, KEPS, 8-32 x 1 1/32	210-458
NUT, HEX, 8-32 x 1/2 x 23/64 (25 W. RESISTOR MOUNTING)	210-462
NUT, 12 SIDED, 15/32-32 x 5/64	210-473
NUT, HEX, 6-32 x 5/16 x .194 (5-10 W. RESISTOR MOUNTING)	210-478
NUT, HEX, 10-32 x 3/8 x 1/8	210-564
NUT, KEPS STEEL 10-32 x 3/8	220-410
PANEL, FRONT, POWER	333-393
PANEL, FRONT, INDICATOR	333-476
PLATE, .040 x 9/16 x 1 9/32	386-427
PLATE, PLEXIGLASS, DELAY LINE, .100 x 1 5/16 x 12 1/4	386-437
PLATE, PLEXIGLAS, DELAY LINE, .100 x 2 1/4 x 8 1/8	386-438
PLATE, CABINET BOTTOM, INDICATOR, BLUE WRINKLE SN 101-599	386-597
PLATE, CABINET BOTTOM, INDICATOR, BLUE VINYL SN 600-3644	387-061
PLATE, CABINET BOTTOM, INDICATOR, BLUE VINYL SN 3645-up	387-718
PLATE, PLUG-IN HOUSING BOTTOM	386-610
PLATE, PLUG-IN HOUSING CRT, LEFT & RIGHT	386-611
PLATE, PLUG-IN HOUSING OUTSIDE, LEFT & RIGHT	386-614
PLATE, PLUG-IN HOUSING, BACK	386-654
PLATE, PLUG-IN HOUSING, TOP	386-655
PLATE, CABINET BOTTOM, POWER, BLUE WRINKLE SN 101-599	386-662
PLATE, CABINET BOTTOM, POWER, BLUE VINYL SN 600-up	387-064
PLATE, PLEXIGLAS, .125 x 1 1/8 x 1/2	386-708
PLATE, PLEXIGLAS, .100 x 1 x 5 1/16	386-709

**Mechanical Parts List (continued)**

	Tektronix Part Number
PLATE, SUB-PANEL, FRONT, POWER	386-712
PLATE, SUB-PANEL, REAR, POWER	386-749
PLATE, PLUG-IN HOUSING, TOP SHIELD .025 x 5 <sup>1</sup> / <sub>16</sub> x 6 <sup>1</sup> / <sub>8</sub>	386-752
PLATE, CABINET SIDE, BLUE WRINKLE (POWER) SN 101-599	386-775
PLATE, CABINET SIDE, BLUE VINYL (POWER) SN 600-up	387-063
PLATE, CABINET SIDE, BLUE WRINKLE (INDICATOR) SN 101-599	386-883
PLATE, CABINET SIDE, BLUE VINYL (INDICATOR) SN 600-3644 (left and right	387-084
PLATE, CABINET SIDE, BLUE VINYL (INDICATOR) SN 3645-up (right only)	387-084
PLATE, CABINET SIDE, BLUE WRINKLE (INDICATOR) SN 3645-up (left only)	387-719
PLATE, TIME BASE REAR	386-895
PLATE, SUB-PANEL FRONT, INDICATOR	386-896
PLATE, H.V. SUPPLY BOARD	386-897
PLATE, SUB-PANEL, REAR, INDICATOR	386-898
PLATE, REAR OVERLAY, INDICATOR, BLUE WRINKLE SN 101-599	386-899
PLATE, REAR OVERLAY, INDICATOR, BLUE VINYL SN 600-up	387-085
PLATE, TIME BASE DIVIDER	386-900
PLATE, REAR OVERLAY, POWER, BLUE WRINKLE SN 101-599	386-913
PLATE, REAR OVERLAY, POWER, BLUE VINYL SN 600-up	387-086
POST, BINDING, 5 WAY ASS'Y	129-036
RING, SECURING STEEL	354-048
RING, FAN .063 x 5 <sup>3</sup> / <sub>4</sub> , POWER	354-051
RING, FAN .063 x 7 <sup>3</sup> / <sub>8</sub> , INDICATOR	354-053
RING, LOCKING SWITCH	354-055
RING, SECURING POLY	354-068
ROD, EXTENSION, 1 <sup>1</sup> / <sub>8</sub> x 16 <sup>5</sup> / <sub>32</sub>	384-182
ROD, POST, NYLON 3 <sup>9</sup> / <sub>8</sub> x 2 <sup>1</sup> 5 <sup>1</sup> / <sub>16</sub>	384-553
ROD, ALUM., HEX 1 <sup>1</sup> / <sub>4</sub> x 7 <sup>1</sup> / <sub>16</sub>	385-080
ROD, NYLON, 5 <sup>1</sup> / <sub>16</sub> x 1 <sup>9</sup> / <sub>16</sub>	385-090
ROD, DELRIN, 5 <sup>1</sup> / <sub>16</sub> x 5 <sup>1</sup> / <sub>8</sub>	385-134
ROD, DELRIN, 5 <sup>1</sup> / <sub>16</sub> x 1 <sup>5</sup> / <sub>16</sub>	385-135
ROD, DELRIN, 5 <sup>1</sup> / <sub>16</sub> x 2 <sup>1</sup> / <sub>4</sub>	385-137
ROD, DELRIN, 5 <sup>1</sup> / <sub>16</sub> x 1 <sup>9</sup> / <sub>16</sub>	385-138
ROD, ALUM., HEX 3 <sup>3</sup> / <sub>8</sub> x 2 <sup>3</sup> / <sub>4</sub> , LEFT SUPPORT SN 101-228	385-102
ROD, ALUM., HEX 3 <sup>3</sup> / <sub>8</sub> x 2 <sup>3</sup> / <sub>4</sub> , LEFT SUPPORT SN 229-up	385-140
SCREW, 4-40 x 1 <sup>1</sup> / <sub>4</sub> BHS	211-008
SCREW, 4-40 x 5 <sup>1</sup> / <sub>16</sub> BHS	211-011

**Mechanical Parts List (continued)**

	Tektronix Part Number
SCREW, 4-40 x 3/8 RHS	211-013
SCREW, 4-40 x 5/8 RHS	211-016
SCREW, 4-40 x 3/8 FHS	211-025
SCREW, 4-40 x 1 FHS	211-031
SCREW, 4-40 x 5/16 PAN HS, W/LOCKWASHER	211-033
SCREW, 4-40 x 1/2 BH NYLON	211-036
SCREW, 4-40 x 5/16 FHS, PHILLIPS	211-038
SCREW, 6-32 x 3/16 BHS	211-503
SCREW, 6-32 x 1/4 BHS	211-504
SCREW, 6-32 x 5/16 BHS	211-507
SCREW, 6-32 x 3/8 BHS	211-510
SCREW, 6-32 x 1/2 BHS	211-511
SCREW, 6-32 x 1/2 FHS, 100°	211-512
SCREW, 6-32 x 5/8 BHS	211-513
SCREW, 6-32 x 5/8 FHS, 100°, PHILLIPS	211-522
SCREW, 6-32 x 5/16 PHS, W/LOCKWASHER	211-534
SCREW, 6-32 x 3/8 TRUSS HS, PHILLIPS	211-537
SCREW, 6-32 x 5/16 FHS, 100°, CSK, PHILLIPS	211-538
SCREW, 6-32 x 1/2 TRUSS HS, PHILLIPS	211-540
SCREW, 6-32 x 1/4 FHS, 100°, CSK, PHILLIPS	211-541
SCREW, 6-32 x 5/16 TRUSS HS, PHILLIPS	211-542
SCREW, 6-32 x 5/16 RHS	211-543
SCREW, 6-32 x 3/4 TRUSS HS, PHILLIPS	211-544
SCREW, 6-32 x 2 BHS	211-552
SCREW, 6-32 x 1 1/2 RHS, PHILLIPS	211-553
SCREW, 8-32 x 5/16 BHS	212-004
SCREW, 8-32 x 1 BHS	212-020
SCREW, 8-32 x 3/8 BHS	212-023
SCREW, 8-32 x 3 3/4 RHS	212-027
SCREW, 8-32 x 1 1/4 RHS	212-031
SCREW, 8-32 x 3 FHS	212-038
SCREW, 8-32 x 3/8 THS, PHILLIPS	212-039
SCREW, 8-32 x 3/8 FHS, 100°, PHILLIPS	212-040
SCREW, 8-32 x 3 3/4 HHS	212-077
SCREW, 10-24 x 7/8 RHS	212-536
SCREW, 10-32 x 5 HHS	212-542
SCREW, 10-32 x 4 3/4 HHS	212-547

**Mechanical Parts List (continued)**

	Tektronix Part Number
SCREW, 4-40 x 3/8 FHS, THREAD CUTTING	213-012
SCREW, 4-40 x 1/4 PHS, PHILLIPS, THREAD CUTTING	213-035
SCREW, 6-32 x 3/8 TRUSS HS, PHILLIPS, THREAD CUTTING	213-041
SCREW, 5-32 x 3/16 PAN H STEEL, PHILLIPS, THREAD CUTTING	213-044
SCREW, 6-32 x 3/8 THREAD FORMING THS	213-104
SHIELD, SOCKET, .770 ID	337-004
SHIELD, SOCKET, 29/32 ID	337-005
SHIELD, TUBE, 7/8 ID W/SPRING 1 5/16 HI	337-007
SHIELD, TUBE, 1 1/32 ID W/SPRING	337-008
SHIELD, TUBE, 1 1/32 ID W/SPRING 2 13/32 HI	337-009
SHIELD, 5" GRATICULE LIGHT	337-187
SHIELD, .020 x 1 7/8 x 1 1/2 x 1 1/4	337-281
SHIELD, CRT	337-282
SHIELD, HORIZ. DISPLAY	337-284
SHIELD, RIGHT HV	337-285
SHIELD, LEFT HV	337-286
SHIELD, CAL 1 3/8 x 1 7/16	337-303
SHIELD, F & I LEFT	337-304
SHIELD, F & I RIGHT	337-305
SHIELD, SILICON DIODE SN 270-450	337-342
SHOCKMOUNT, RUBBER 1/2 x 1/2	348-008
SOCKET, STM7G	136-008
SOCKET, STM8, GROUND	136-011
SOCKET, STM9G	136-015
SOCKET, STM14 1 1/8" THICK, MICA, 14 PIN	136-019
SOCKET, LIGHT, JEWEL	136-025
SOCKET, GROUNDING TYPE, 3 COND. 15 AMP.	136-036
SPACER, NYLON FOR CERAMIC STRIPS, 1/16	361-007
SPACER, NYLON FOR CERAMIC STRIPS, 3/16	361-008
SPACER, NYLON FOR CERAMIC STRIPS, 5/16	361-009
SPRING, 9/32 x 1/8 x .075	214-123
SPOOL ASS'Y of molded nylon	214-210
STEM, BINDING POST ADAPTER	355-507
STRAP, MOUNTING BRACKET, .025 x 5/16 x 4 1/4	346-001
STRAP, MOUNTING BRACKET, .025 x 5/16 x 5 3/8	346-010
STRIP, CERAMIC, 3/4 x 3 NOTCHES, CLIP MOUNTED	124-087
STRIP, CERAMIC, 3/4 x 4 NOTCHES, CLIP MOUNTED	124-088
STRIP, CERAMIC, 3/4 x 7 NOTCHES, CLIP MOUNTED	124-089

**Mechanical Parts List** (continued)

	Tektronix Part Number
STRIP, CERAMIC, $\frac{3}{4}$ x 9 NOTCHES, CLIP MOUNTED	124-090
STRIP, CERAMIC, $\frac{3}{4}$ x 11 NOTCHES, CLIP MOUNTED	124-091
STRIP, CERAMIC, $\frac{3}{4}$ x 1 NOTCH, CLIP MOUNTED	124-100
STUD, STEEL 10-32 x $2\frac{7}{16}$ W/2" SHOULDER	355-044
STUD, NYLON FOR CERAMIC STRIPS	355-046
STUD, ROLLED STEEL, 4-40 x $\frac{3}{16}$ SN 300-up	355-050
TAG, VOLTAGE RATING	334-649
TAG, S/N INSERT	334-679
TUBE, SPACER, .180 x $\frac{1}{4}$ x $\frac{1}{8}$	166-029
TUBE, SPACER, .180 x $\frac{1}{4}$ x $\frac{3}{16}$	166-030
TUBE, SPACER, .180 x $\frac{1}{4}$ x $\frac{5}{8}$	166-037
TUBE, SPACER, .180 x $\frac{1}{4}$ x $\frac{3}{4}$	166-038
TUBE, SPACER, .196 x $\frac{5}{16}$ x $\frac{3}{16}$	166-093
TUBE, SPACER, .245 x $\frac{3}{8}$ x $2\frac{1}{32}$	166-098
TUBE, SPACER, .180 x $\frac{1}{4}$ x $1\frac{23}{32}$ SN 270-450	166-099
WASHER, STEEL, 5S x $\frac{9}{32}$ x .025	210-801
WASHER, STEEL, 6L x $\frac{3}{8}$ x .032	210-803
WASHER, STEEL, 8S x $\frac{3}{8}$ x .032	210-804
WASHER, STEEL, 10S x $\frac{7}{16}$ x .036	210-805
WASHER, BRASS, 20 W RESISTOR CENTERING	210-808
WASHER, BRASS, 25 W RESISTOR CENTERING	210-809
WASHER, FIBER, #10	210-812
WASHER, RUBBER	210-816
WASHER, STEEL, .390 x $\frac{9}{16}$ x .020	210-840
WASHER, STEEL, .093 x $\frac{9}{32}$ x .020	210-850
WASHER, STEEL, .119 x $\frac{3}{8}$ x .025	210-851
WASHER, RUBBER, FOR FUSE HOLDER	210-873
WASHER, BRASS, $\frac{9}{64}$ ID x $\frac{1}{2}$ OD x $\frac{1}{16}$	210-949

# PARTS LIST

## TYPE 21

### Bulbs

							Tektronix Part Number
B129		Type NE-2 Neon Bulb					150-002
B160W		Type NE-2 Neon Bulb					150-002
B167		Type NE-2 Neon Bulb					150-002
B170		Type NE-2 Neon Bulb					150-002

### Capacitors

C1		10 $\mu\mu\text{f}$	Cer.	Fixed	500 v	$\pm 1 \mu\mu\text{f}$	281-504
C2	X4730-up	.01 $\mu\text{f}$	Cer.	Fixed	500 v		283-002
C5	X4730-up	.01 $\mu\text{f}$	Cer.	Fixed	500 v		283-002
C6		10 $\mu\mu\text{f}$	Cer.	Fixed	500 v	$\pm 1 \mu\mu\text{f}$	281-504
C10		.001 $\mu\text{f}$	Cer.	Fixed	500 v		283-000
C11	101-679X	.001 $\mu\text{f}$	Cer.	Fixed	500 v		283-000
C15		.001 $\mu\text{f}$	Cer.	Fixed	500 v		283-000
C20		.001 $\mu\text{f}$	Cer.	Fixed	500 v		283-000
C24		47 $\mu\mu\text{f}$	Cer.	Fixed	500 v	20%	281-518
C31		.01 $\mu\text{f}$	PTM	Fixed	100 v	10%	285-554
C37		22 $\mu\mu\text{f}$	Cer.	Fixed	500 v	20%	281-511
C47		.005 $\mu\text{f}$	Cer.	Fixed	500 v		283-001
C101		.005 $\mu\text{f}$	Cer.	Fixed	500 v		283-001
C102		470 $\mu\mu\text{f}$	Cer.	Fixed	500 v	$\pm 94 \mu\mu\text{f}$	281-525
C116		.001 $\mu\text{f}$	Cer.	Fixed	500 v		283-000
C123		10 $\mu\mu\text{f}$	Cer.	Fixed	500 v	10%	281-504
C129		.005 $\mu\text{f}$	Cer.	Fixed	500 v		283-001
C131		27 $\mu\mu\text{f}$	Cer.	Fixed	500 v	$\pm 4.5 \mu\mu\text{f}$	281-513
C134		4.7 $\mu\mu\text{f}$	Cer.	Fixed	500 v	$\pm 1 \mu\mu\text{f}$	281-501
C138		.01 $\mu\text{f}$	Cer.	Fixed	500 v		283-002
C141		8 $\mu\mu\text{f}$	Cer.	Fixed	500 v	$\pm 0.5 \mu\mu\text{f}$	281-503
C150		82 $\mu\mu\text{f}$	Cer.	Fixed	500 v	10%	281-528
C160A		3-12 $\mu\mu\text{f}$	Cer.	Var.			281-007
C160B		82 $\mu\mu\text{f}$	Mica	Fixed	500 v	5%	283-534
C160C		4.5-25 $\mu\mu\text{f}$	Cer.	Var.			281-010
C160D		82 $\mu\mu\text{f}$	Mica	Fixed	500 v	5%	283-534
C160E		4.5-25 $\mu\mu\text{f}$	Cer.	Var.			281-010
C160F		.001 $\mu\text{f}$	Mylar	Fixed		$\pm 1/2\%$	*291-008
C160G,H,J	.01 $\mu\text{f}$ .1 $\mu\text{f}$ 1 $\mu\text{f}$	Mylar Timing Series				$\pm 1/2\%$	*291-007
C165		82 $\mu\mu\text{f}$	Cer.	Fixed	500 v	10%	281-528
C167		.001 $\mu\text{f}$	Cer.	Fixed	500 v		283-000
C174		27 $\mu\mu\text{f}$	Cer.	Fixed	500 v	$\pm 5.4 \mu\mu\text{f}$	281-513
C180A		220 $\mu\mu\text{f}$	Mica	Fixed	500 v	10%	283-536
C180B		.0022 $\mu\text{f}$	PTM	Fixed	400 v	20%	285-543
C180C		.022 $\mu\text{f}$	PTM	Fixed	400 v	20%	285-515
C180D		.1 $\mu\text{f}$	PTM	Fixed	400 v		285-526
C180E		.1 $\mu\text{f}$	PTM	Fixed	400 v		285-526

**Capacitors (continued)**

							Tektronix Part Number
C181		39 $\mu\mu\text{f}$	Cer.	Fixed	500 v	10%	281-517
C186		.001 $\mu\text{f}$	Cer.	Fixed	500 v		283-000
C191		120 $\mu\mu\text{f}$	Cer.	Fixed			281-550
C193		.02 $\mu\text{f}$	Cer.	Fixed	600 v		283-006
C195		18 $\mu\mu\text{f}$	Cer.	Fixed	500 v	10%	281-542
C198		.005 $\mu\text{f}$	Cer.	Fixed	500 v		283-001

**Diodes**

D132	X1433-up	Diode, Germanium, Type T12G					152-008
------	----------	-----------------------------	--	--	--	--	---------

**Inductors**

LR149		1.59 mh					108-173
L1		Ferrite Bead, Parasitic Suppressor					276-507
L6		Ferrite Bead, Parasitic Suppressor					276-507

**Resistors**

R1		1 meg	$\frac{1}{2}$ w	Fixed	Comp.	10%	302-105
R2		390 k	$\frac{1}{2}$ w	Fixed	Comp.	10%	302-394
R3		50 k	.2 w	Var.	Comp.	$\pm 20\%$	311-125
R4		100 k	$\frac{1}{2}$ w	Fixed	Comp.	10%	302-104
R5	X4730-up	10 meg	$\frac{1}{2}$ w	Fixed	Comp.	10%	302-106
R6		1 meg	$\frac{1}{2}$ w	Fixed	Comp.	10%	302-105
R7		390 k	$\frac{1}{2}$ w	Fixed	Comp.	10%	302-394
R8		50 k	.2 w	Var.	Comp.	$\pm 20\%$	311-125
R9		100 k	$\frac{1}{2}$ w	Fixed	Comp.	10%	302-104
R10	X4730-up	10 meg	$\frac{1}{2}$ w	Fixed	Comp.	10%	302-106
R12		1 meg	$\frac{1}{2}$ w	Fixed	Comp.	10%	302-105
R15		470 k	$\frac{1}{2}$ w	Fixed	Comp.	10%	302-474
R17		100 k	.2 w	Var.	Comp.		311-026
R18		22 k	$\frac{1}{2}$ w	Fixed	Comp.	10%	302-223
R19		470 k	$\frac{1}{2}$ w	Fixed	Comp.	10%	302-474
R20		56 k	$\frac{1}{2}$ w	Fixed	Comp.	10%	302-563
R22		47 $\Omega$	$\frac{1}{2}$ w	Fixed	Comp.	10%	302-470
R23		47 $\Omega$	$\frac{1}{2}$ w	Fixed	Comp.	10%	302-470
R24		4.7 k	1 w	Fixed	Comp.	10%	304-472
R25		4.7 k	1 w	Fixed	Comp.	10%	304-472
R28		33 k	.2 w	Fixed	Comp.	10%	306-333
R29		39 k	.2 w	Fixed	Comp.	10%	306-393
R31		47 k	$\frac{1}{2}$ w	Fixed	Comp.	10%	302-473
R32		47 k	$\frac{1}{2}$ w	Fixed	Comp.	10%	302-473
R33		47 $\Omega$	$\frac{1}{2}$ w	Fixed	Comp.	10%	302-470
R34		680 $\Omega$	$\frac{1}{2}$ w	Fixed	Comp.	10%	302-681
R35		1.5 k	$\frac{1}{2}$ w	Fixed	Comp.	10%	302-152
R37		100 k	$\frac{1}{2}$ w	Fixed	Comp.	10%	302-104
R38		100 k	$\frac{1}{2}$ w	Fixed	Comp.	10%	302-104
R39		100 k	.2 w	Var.	Comp.	$\pm 20\%$	311-088
R40		2.7 meg	$\frac{1}{2}$ w	Fixed	Comp.	10%	302-275
R41		47 $\Omega$	$\frac{1}{2}$ w	Fixed	Comp.	10%	302-470
R43		1.5 k	$\frac{1}{2}$ w	Fixed	Comp.	10%	302-152
R46		18 k	1 w	Fixed	Comp.	10%	304-183
R47		500 $\Omega$	.2 w	Var.	Comp.	20%	311-066
R48		18 k	1 w	Fixed	Comp.	10%	304-183
R101		4.7 meg	$\frac{1}{2}$ w	Fixed	Comp.	10%	302-475

## Resistors (continued)

							Tektronix Part Number
R102		2.2 k	1/2 w	Fixed	Comp.	10%	302-222
R111		100 k	2 w	Var.	Comp.		311-026
R114		470 k	1/2 w	Fixed	Comp.	10%	302-474
R115		100 k	1/2 w	Fixed	Comp.	5%	301-104
R116		180 k	1/2 w	Fixed	Comp.	5%	301-184
R118		680 k	1/2 w	Fixed	Comp.	10%	302-684
R119		47 $\Omega$	1/2 w	Fixed	Comp.	10%	302-470
R121	101-589	1 k	1/2 w	Fixed	Comp.	10%	use 302-472
R121	590-up	4.7 k	1/2 w	Fixed	Comp.	10%	302-472
R122	101-589	22 k	1/2 w	Fixed	Comp.	10%	use 302-183
R122	590-up	18 k	1/2 w	Fixed	Comp.	10%	302-183
R123		270 k	1/2 w	Fixed	Comp.	10%	302-274
R124		470 k	1/2 w	Fixed	Comp.	10%	302-474
R125		50 k	.2 w	Var.	Comp.	$\pm 20\%$	311-125
R126		100 k	1/2 w	Fixed	Comp.	10%	302-104
R127		47 $\Omega$	1/2 w	Fixed	Comp.	10%	302-470
R128		12 k	1/2 w	Fixed	Comp.	10%	302-123
R129		10 k	1/2 w	Fixed	Comp.	10%	302-103
R130		22 k	2 w	Fixed	Comp.	10%	306-223
R131		1 k	1/2 w	Fixed	Comp.	10%	302-102
R132		47 $\Omega$	1/2 w	Fixed	Comp.	10%	302-470
R134		6 k	2 w	Fixed	Prec.	1%	310-555
R137		47 $\Omega$	1/2 w	Fixed	Comp.	10%	302-470
R138		100 $\Omega$	1/2 w	Fixed	Comp.	10%	302-101
R141		33 k	1 w	Fixed	Prec.	1%	310-070
R143		30 k	1 w	Fixed	Prec.	1%	310-072
R144		8 k	5 w	Fixed	WW	5%	308-053
R146		47 $\Omega$	1/2 w	Fixed	Comp.	10%	302-470
R147		1 k	1/2 w	Fixed	Comp.	10%	302-102
R148		39 k	1/2 w	Fixed	Comp.	10%	302-393
R150		270 $\Omega$	1/2 w	Fixed	Comp.	10%	302-271
R160A		100 k	1/2 w	Fixed	Prec.	1%	309-045
R160B		200 k	1/2 w	Fixed	Prec.	1%	309-051
R160C		500 k	1/2 w	Fixed	Prec.	1%	309-003
R160D	101-1679	1 meg	1/2 w	Fixed	Prec.	1%	Use 309-359
R160D	1680-up	1 meg	1/2 w	Fixed	Prec.	1/4%	309-359
R160E		2 meg	1/2 w	Fixed	Prec.	1%	309-023
R160F		5 meg	1/2 w	Fixed	Prec.	1%	309-087
R160G		10 meg	1 w	Fixed	Prec.	1%	310-107
R160H		10 meg	1 w	Fixed	Prec.	1%	310-107
R160J		30 meg	2 w	Fixed	Prec.	1%	310-505
R160W		100 k	1/2 w	Fixed	Comp.	10%	302-104
R160X		10 k	1/2 w	Fixed	Comp.	10%	302-103
R160Y		20 k		Fixed	WW	$\pm 10\%$	311-108
R162		6.8 k	1 w	Fixed	Comp.	10%	Use 304-682
R163		12 k	1 w	Fixed	Comp.	10%	Use 304-123
R164		22 k	2 w	Fixed	Comp.	10%	306-223
R165		22 k	2 w	Fixed	Comp.	10%	306-223
R166		22 k	2 w	Fixed	Comp.	10%	306-223
R167		1.5 meg	1/2 w	Fixed	Comp.	10%	302-155
R168		47 k	1/2 w	Fixed	Comp.	10%	302-470
R170		47 $\Omega$	1/2 w	Fixed	Comp.	10%	302-470
R172		47 $\Omega$	1/2 w	Fixed	Comp.	10%	302-473

### Resistors (continued)

							Tektronix Part Number
R174		8 k	5 w	Fixed	WW	5%	308-053
R175		47 Ω	1/2 w			10%	302-470
R176		2 k	2 w	Var.	Comp.		311-008
R178		4 k	5 w	Fixed	WW	5%	308-051
R180A		470 k	1/2 w	Fixed	Comp.	10%	302-474
R180B		4.7 meg	1/2 w	Fixed	Comp.	10%	302-475
R181		4.7 meg	1/2 w	Fixed	Comp.	10%	302-475
R183		47 Ω	1/2 w	Fixed	Comp.	10%	302-470
R186		100 k	1/2 w	Fixed	Comp.	10%	302-104
R188		100 k	1 w	Fixed	Comp.	10%	use 304-104
R190		2.2 meg	1/2 w	Fixed	Comp.	10%	302-225
R191		100 k	1/2 w	Fixed	Comp.	10%	302-104
R192		47 Ω	1/2 w	Fixed	Comp.	10%	302-470
R193		100 Ω	1/2 w	Fixed	Comp.	10%	302-101
R194		68 k	2 w	Fixed	Comp.	10%	306-683
R195		47 k	1/2 w	Fixed	Comp.	10%	302-473
R196	101-589	100 k	1/2 w	Fixed	Comp.	10%	use 301-114
R196	590-up	110 k	1/2 w	Fixed	Comp.	5%	301-114
R197		47 Ω	1/2 w	Fixed	Comp.	10%	302-470
R198		47 Ω	1/2 w	Fixed	Comp.	10%	302-470
R199		4.7 k	1 w	Fixed	Comp.	10%	304-472

### Switches

			Wired	Unwired
SW8	101-4729	Source Switch	use *050-092	260-271
SW8	4730-up	Source Switch	262-560	260-271
SW10		Switch Coupling		260-145
SW17	101-679	Level Switch	262-192	260-272
SW17	680-up	Level Switch	262-381	260-354
SW22		Switch Slope		260-212
SW101		Switch Reset		260-247
SW128		Sweep Function Switch	262-197	260-273
SW160	101-1432	Time/Cm	262-191	260-275
SW160Y†	1433-up	Time/Cm	262-418	260-275
				311-108

### Vacuum Tubes

V24		6DJ8		154-187
V45		6DJ8		154-187
V125		6AU6		154-022
V133		6DJ8		154-187
V135		6DJ8		154-187
V145		12BY7		154-047
V152		12AL5	use *157-075	
V161		12AU6		154-040
V173		6DJ8		154-187
V183		6DJ8		154-187
V193		6DJ8		154-187

† Furnished as a unit with R160Y.

# Type 21 Mechanical Parts List

	Tektronix Part Number
BUSHING, $\frac{3}{8}$ -32 x $\frac{9}{16}$ x .412	358-010
BUSHING, HEX, PANEL, $\frac{3}{8}$ -32 x $\frac{13}{32}$	358-029
BUSHING, NYLON, FOR 5-WAY, BINDING POST	358-036
BRACKET, CHASSIS SUPPORT	406-425
BRACKET, TIME/CM SWITCH	406-489
CABLE, HARNESS, SWEEP #1 (SN 101-1432)	179-288
CABLE, HARNESS, SWEEP #1 (SN 1433-up)	179-535
CABLE, HARNESS, SWEEP #2 (SN 101-1432)	179-289
CABLE, HARNESS, SWEEP #2 (SN 1433-up)	179-536
CHASSIS	441-255
CLAMP, #20 WIRE FOR NEON BULBS	343-043
CONNECTOR, CHASSIS MTG., COAX, (SN 101-4947)	131-081
CONNECTOR, CHASSIS MTG. BNC (SN 4948-up)	131-126
CONNECTOR, CHASSIS MTD., 32 CONTACT, MALE, AMPH.	131-096
COUPLING, POT	376-014
FOOT, WHITE NYLON	348-023
GROMMET, RUBBER, $\frac{1}{4}$	348-002
GROMMET, RUBBER, $\frac{5}{16}$	348-003
GROMMET, RUBBER, $\frac{3}{8}$	348-004
HOLDER, NEON BULB, SINGLE	352-008
KNOB, SMALL BLACK, $\frac{1}{4}$ " HOLE PART WAY	366-033
KNOB, SMALL RED, $\frac{3}{16}$ HOLE PART WAY	366-038
KNOB, LARGE BLACK,	366-058
KNOB, SMALL BLACK, W/HOLE THRU	366-070
LOCKWASHER, INT. #4	210-004
LOCKWASHER, INT. #6	210-006
LOCKWASHER, INT. #10	210-010
LOCKWASHER, INT., $\frac{1}{4}$	210-011
LOCKWASHER, INT., POT, $\frac{3}{8}$ x $\frac{1}{2}$	210-012
LOCKWASHER, INT $\frac{1}{4}$	210-046
LOCKWASHER, INT., $\frac{3}{8}$ x $\frac{11}{16}$	210-013
LOCKWASHER, SPRING, #5	210-117
LUG, SOLDER, SE4	210-201
LUG, SOLDER, SE6 W/2 WIRE HOLES	210-202
LUG, SOLDER, SE10, LONG	210-206
LUG, SOLDER, POT, PLAIN, $\frac{3}{8}$	210-207

**Mechanical Parts List (continued)**

	Tektronix Part Number
NUT, HEX, 4-40 x 3/16	210-406
NUT, HEX, 6-32 x 1/4	210-407
NUT, HEX, 3/8-32 x 1/2	210-413
NUT, HEX, 10-32 x 3/8 x 1/8	210-436
NUT, HEX, 1/4-28 x 3/8 x 3/32	210-455
NUT, KEPS, 6-32 x 5/16	210-457
NUT, HEX, 3/8-32 x 1/2 x 1 1/16	210-494
PANEL, FRONT	333-444
PLATE, SUBPANEL, FRONT	386-870
PLATE, REAR	387-570
POST, BINDING, 5-WAY	129-036
POST, BINDING, ASS'Y	129-051
ROD, EXTENSION, NYLON, RED	384-179
ROD, EXTENSION, STEEL	384-183
ROD, FRAME, ALUMINUM (SN 101-650)	384-515
ROD, FRAME, BRASS W/CHROME PLATE (SN 651-up)	384-566
ROD, DELRIN 5/16 x 1 5/16 W/2 #44 CROSS HOLES	385-135
SCREW, 4-40 x 5/16 BHS	211-011
SCREW, 4-40 x 3/8 BHS	211-012
SCREW, 4-40 x 1 FHS	211-031
SCREW, 4-40 x 5/16 FHS, PHILLIPS	211-038
SCREW, 6-32 x 5/16 BHS	211-507
SCREW, 6-32 x 5/16 FHS, 100°, CSK, PHILLIPS	212-538
SCREW, 8-32 x 1/2 FHS, 100°, PHILLIPS	212-043
SCREW, 8-32 x 1/2 RHS, PHILLIPS	212-044
SCREW, 5-32 x 3/16 PAN H STEEL, THREAD CUTTING, PHILLIPS	213-044
SPACER, NYLON, 3/16, FOR CERAMIC STRIPS	361-008
SOCKET, STM7G	136-008
SOCKET, STM9G	136-015
STRIP, CERAMIC, 3/4 x 9 NOTCHES, CLIP MTD.	124-090
STRIP, CERAMIC, 3/4 x 11 NOTCHES, CLIP MTD.	124-091
TAG, S/N INSERT	334-679
WASHER, STEEL, 6L x 3/8 x .032	210-803
WASHER, STEEL, .390 x 3/16 x .020	210-840

# PARTS LIST

## TYPE 22

### Bulbs

B129	Type NE-2 Neon Bulb	150-002
B160W	Type NE-2 Neon Bulb	150-002
B167	Type NE-2 Neon Bulb	150-002
B170	Type NE-2 Neon Bulb	150-002

### Capacitors

C2	X4750-up	.01 $\mu$ f	Cer.	Fixed	500 v		283-002
C5	X4750-up	.01 $\mu$ f	Cer.	Fixed	500 v		283-002
C1		10 $\mu$ $\mu$ f	Cer.	Fixed	500 v	$\pm 1 \mu$ $\mu$ f	281-504
C6		10 $\mu$ $\mu$ f	Cer.	Fixed	500 v	$\pm 1 \mu$ $\mu$ f	281-504
C10		.001 $\mu$ f	Cer.	Fixed	500 v		283-000
C11	101-679X	.001 $\mu$ f	Cer.	Fixed	500 v		283-000
C15		.001 $\mu$ f	Cer.	Fixed	500 v		283-000
C20		.001 $\mu$ f	Cer.	Fixed	500 v		283-000
C24		47 $\mu$ $\mu$ f	Cer.	Fixed	500 v	20%	281-518
C31		.01 $\mu$ f	PTM	Fixed	100 v	10%	285-554
C37		22 $\mu$ $\mu$ f	Cer.	Fixed	500 v	20%	281-511
C47		.005 $\mu$ f	Cer.	Fixed	500 v		283-001
C101		.001 $\mu$ f	Cer.	Fixed	500 v		283-000
C102		22 $\mu$ $\mu$ f	Cer.	Fixed	500 v	20%	281-511
C106		.001 $\mu$ f	Cer.	Fixed	500 v		283-000
C109		.005 $\mu$ f	Cer.	Fixed	500 v		283-001
C116		.001 $\mu$ f	Cer.	Fixed	500 v		283-000
C123		10 $\mu$ $\mu$ f	Cer.	Fixed	500 v	$\pm 1 \mu$ $\mu$ f	281-504
C129		.005 $\mu$ f	Cer.	Fixed	500 v		283-001
C131		27 $\mu$ $\mu$ f	Cer.	Fixed	500 v	$\pm 4.5 \mu$ $\mu$ f	281-513
C134		4.7 $\mu$ $\mu$ f	Cer.	Fixed	500 v	$\pm 1 \mu$ $\mu$ f	281-501
C138		.01 $\mu$ f	Cer.	Fixed	500 v		283-002
C141		8 $\mu$ $\mu$ f	Cer.	Fixed	500 v	$\pm 0.5 \mu$ $\mu$ f	281-503
C150		82 $\mu$ $\mu$ f	Cer.	Fixed	500 v	10%	281-528
C160A		3-12 $\mu$ $\mu$ f	Cer.	Var.			281-007
C160B		82 $\mu$ $\mu$ f	Mica	Fixed	500 v	5%	283-534
C160C		4.5-25 $\mu$ $\mu$ f	Cer.	Var.			281-010
C160D		82 $\mu$ $\mu$ f	Mica	Fixed	500 v	5%	283-534
C160E		4.5-25 $\mu$ $\mu$ f	Cer.	Var.			281-010
C160F		.001 $\mu$ f	Mylar	Fixed		$\pm 1/2 \%$	*291-008
C160G		.01 $\mu$ f	Mylar Timing Series			$\pm 1/2 \%$	*291-007
C160H		.1 $\mu$ f					
C160J		.1 $\mu$ f					
		.1 $\mu$ f					
C165		82 $\mu$ $\mu$ f	Cer.	Fixed	500 v	10%	281-528
C167		.001 $\mu$ f	Cer.	Fixed	500 v		283-000
C174		27 $\mu$ $\mu$ f	Cer.	Fixed	500 v	20%	281-513
C180A		220 $\mu$ $\mu$ f	Mica	Fixed	500 v	10%	283-536
C180B		.0022 $\mu$ f	PTM	Fixed	400 v	20%	285-543
C180C		.022 $\mu$ f	PTM	Fixed	400 v	20%	285-515

### Capacitors (continued)

C180D	.1 $\mu$ f	PTM	Fixed	400 v		285-526
C180E	.1 $\mu$ f	PTM	Fixed	400 v		285-526
C181	39 $\mu$ f	Cer.	Fixed	500 v	10%	281-517
C186	.001 $\mu$ f	Cer.	Fixed	500 v		283-000
C191	120 $\mu$ f	Cer.	Fixed	500 v		281-550
C193	.02 $\mu$ f	Cer.	Fixed	600 v		283-006
C195	18 $\mu$ f	Cer.	Fixed	500 v		281-542
C198	.005 $\mu$ f	Cer.	Fixed	500 v		283-001

### Inductors

LR149	1.59 mh					108-173
L1	Ferrite Bead, Parasitic Suppressor					276-507
L6	Ferrite Bead, Parasitic Suppressor					276-507

### Resistors

R1	1 meg	$\frac{1}{2}$ w	Fixed	Comp.	10%	302-105
R2	390 k	$\frac{1}{2}$ w	Fixed	Comp.	10%	302-394
R3	50 k	.2 w	Var.	Comp.	20%	311-125
R4	100 k	$\frac{1}{2}$ w	Fixed	Comp.	10%	302-104
R5	10 meg	$\frac{1}{2}$ w	Fixed	Comp.	10%	302-106
R6	1 meg	$\frac{1}{2}$ w	Fixed	Comp.	10%	302-105
	X4750-up					
R7	390 k	$\frac{1}{2}$ w	Fixed	Comp.	10%	302-394
R8	50 k	.2 w	Var.	Comp.	20%	311-125
R9	100 k	$\frac{1}{2}$ w	Fixed	Comp.	10%	302-104
R10	10 meg	$\frac{1}{2}$ w	Fixed	Comp.	10%	302-106
R12	1 meg	$\frac{1}{2}$ w	Fixed	Comp.	10%	302-105
R15	470 k	$\frac{1}{2}$ w	Fixed	Comp.	10%	302-474
	X4750-up					
R17	100 k	2 w	Var.	Comp.		311-026
R18	22 k	$\frac{1}{2}$ w	Fixed	Comp.	10%	302-223
R19	470 k	$\frac{1}{2}$ w	Fixed	Comp.	10%	302-474
R20	56 k	$\frac{1}{2}$ w	Fixed	Comp.	10%	302-563
R22	47 $\Omega$	$\frac{1}{2}$ w	Fixed	Comp.	10%	302-470
R23	47 $\Omega$	$\frac{1}{2}$ w	Fixed	Comp.	10%	302-470
R24	4.7 k	1 w	Fixed	Comp.	10%	304-472
R25	4.7 k	1 w	Fixed	Comp.	10%	304-472
R28	33 k	2 w	Fixed	Comp.	10%	306-333
R29	39 k	2 w	Fixed	Comp.	10%	306-393
R31	47 k	$\frac{1}{2}$ w	Fixed	Comp.	10%	302-473
R32	47 k	$\frac{1}{2}$ w	Fixed	Comp.	10%	302-473
R33	47 $\Omega$	$\frac{1}{2}$ w	Fixed	Comp.	10%	302-470
R34	680 $\Omega$	$\frac{1}{2}$ w	Fixed	Comp.	10%	302-681
R35	1.5 k	$\frac{1}{2}$ w	Fixed	Comp.	10%	302-152
R37	100 k	$\frac{1}{2}$ w	Fixed	Comp.	10%	302-104
R38	100 k	$\frac{1}{2}$ w	Fixed	Comp.	10%	302-104
R39	100 k	.2 w	Var.	Comp.	20%	311-088
R40	2.7 meg	$\frac{1}{2}$ w	Fixed	Comp.	10%	302-275
R41	47 $\Omega$	$\frac{1}{2}$ w	Fixed	Comp.	10%	302-470
R43	1.5 k	$\frac{1}{2}$ w	Fixed	Comp.	10%	302-152
R46	18 k	1 w	Fixed	Comp.	10%	304-183
R47	500 $\Omega$	.2 w	Var.	Comp.	20%	311-066
R48	18 k	1 w	Fixed	Comp.	10%	304-183
R101	22 meg	$\frac{1}{2}$ w	Fixed	Comp.	10%	302-226

## Resistors (continued)

R102		22 k	1/2 w	Fixed	Comp.	10%	302-223
R103		1 k	1/2 w	Fixed	Comp.	10%	302-102
R105		390 k	1/2 w	Fixed	Comp.	10%	302-394
R106		1 meg	1/2 w	Fixed	Comp.	10%	302-105
R107		47 Ω	1/2 w	Fixed	Comp.	10%	302-470
R109		220 k	1/2 w	Fixed	Comp.	10%	302-224
R111		100 k	2 w	Var.	Comp.		311-026
R114		470 k	1/2 w	Fixed	Comp.	10%	302-474
R115		100 k	1/2 w	Fixed	Comp.	5%	301-104
R116		180 k	1/2 w	Fixed	Comp.	5%	301-184
R118		680 k	1/2 w	Fixed	Comp.	10%	302-684
R119		47 Ω	1/2 w	Fixed	Comp.	10%	302-470
R122		68 k	1 w	Fixed	Comp.	10%	304-683
R123		270 k	1/2 w	Fixed	Comp.	10%	302-274
R124		470 k	1/2 w	Fixed	Comp.	10%	302-474
R125		50 k	.2 w	Var.	Comp.	20%	311-125
R126		100 k	1/2 w	Fixed	Comp.	10%	302-104
R127		47 Ω	1/2 w	Fixed	Comp.	10%	302-470
R128		12 k	1/2 w	Fixed	Comp.	10%	302-123
R129		10 k	1/2 w	Fixed	Comp.	10%	302-103
R130		22 k	2 w	Fixed	Comp.	10%	306-223
R131		1 k	1/2 w	Fixed	Comp.	10%	302-102
R132		47 Ω	1/2 w	Fixed	Comp.	10%	302-470
R134		6 k	3 w	Fixed	Prec.		310-555
R137		47 Ω	1/2 w	Fixed	Comp.	10%	302-470
R138		100 Ω	1/2 w	Fixed	Comp.	10%	302-101
R141		33 k	1 w	Fixed	Prec.	1%	310-070
R143		30 k	1 w	Fixed	Prec.	1%	310-072
R144		8 k	5 w	Fixed	WW	5%	308-053
R146		47 Ω	1/2 w	Fixed	Comp.	10%	302-470
R147		1 k	1/2 w	Fixed	Comp.	10%	302-102
R148		39 k	1/2 w	Fixed	Comp.	10%	302-393
R150		270 Ω	1/2 w	Fixed	Comp.	10%	302-271
R160A		100 k	1/2 w	Fixed	Prec.	1%	309-045
R160B		200 k	1/2 w	Fixed	Prec.	1%	309-051
R160C		500 k	1/2 w	Fixed	Prec.	1%	309-003
R160D	101-1679	1 meg	1/2 w	Fixed	Prec.	1%	Use 309-359
R160D	1680-up	1 meg	1/2 w	Fixed	Prec.	1/4%	309-359
R160E		2 meg	1/2 w	Fixed	Prec.	1%	309-023
R160F		5 meg	1/2 w	Fixed	Prec.	1%	309-087
R160G		10 meg	1 w	Fixed	Prec.	1%	310-107
R160H		10 meg	1 w	Fixed	Prec.	1%	310-107
R160J		30 meg	2 w	Fixed	Prec.	1%	310-505
R160W		100 k	1/2 w	Fixed	Comp.	10%	302-104
R160X		10 k	1/2 w	Fixed	Comp.	10%	302-103
R160Y		20 k		Var.	WW	10%	311-108
R162		6.8 k	1 w	Fixed	Comp.	10%	Use 304-682
R163		12 k	1 w	Fixed	Comp.	10%	Use 304-123
R164		22 k	2 w	Fixed	Comp.	10%	306-223
R165		22 k	2 w	Fixed	Comp.	10%	306-223
R166		22 k	2 w	Fixed	Comp.	10%	306-223

**Resistors (continued)**

R167	1.5 meg	1/2 w	Fixed	Comp.	10%	302-155
R168	47 k	1/2 w	Fixed	Comp.	10%	302-473
R170	47 Ω	1/2 w	Fixed	Comp.	10%	302-470
R172	47 Ω	1/2 w	Fixed	Comp.	10%	302-470
R174	8 k	5 w	Fixed	WW	5%	308-053
R175	47 Ω	1/2 w	Fixed	Comp.	10%	302-470
R176	2 k	2 w	Var.	Comp.		311-008
R178	4 k	5 w	Fixed	WW	5%	308-051
R180A	470 k	1/2 w	Fixed	Comp.	10%	302-474
R180B	4.7 meg	1/2 w	Fixed	Comp.	10%	302-475
R181	4.7 meg	1/2 w	Fixed	Comp.	10%	302-475
R182	47 Ω	1/2 w	Fixed	Comp.	10%	302-470
R183	47 Ω	1/2 w	Fixed	Comp.	10%	302-470
R186	100 k	1/2 w	Fixed	Comp.	10%	302-104
R188	100 k	1 w	Fixed	Comp.	10%	Use 304-104
R190	2.2 meg	1/2 w	Fixed	Comp.	10%	302-225
R191	100 k	1/2 w	Fixed	Comp.	10%	302-104
R192	47 Ω	1/2 w	Fixed	Comp.	10%	302-470
R193	100 Ω	1/2 w	Fixed	Comp.	10%	302-101
R194	68 k	2 w	Fixed	Comp.	10%	306-683
R195	47 k	1/2 w	Fixed	Comp.	10%	302-473
R196	110 k	1/2 w	Fixed	Comp.	5%	301-114
R197	47 Ω	1/2 w	Fixed	Comp.	10%	302-470
R198	47 Ω	1/2 w	Fixed	Comp.	10%	302-470
R199	4.7 k	1 w	Fixed	Comp.	10%	304-472

**Switches**

			Wired	Unwired
SW8	101-4749	Source Switch	Use *050-092	260-271
SW8	4750-up	Source Switch	262-560	260-271
SW10		Switch Coupling		260-145
SW17	101-679	Level Switch	262-192	260-272
SW17	680-up	Level Switch	262-381	260-354
SW22		Switch Slope		260-212
SW101		Switch Reset		260-247
SW120		Sweep Function	262-194	260-274
SW160		Time/Cm	262-191	260-275

**Vacuum Tubes**

V24	6DJ8	154-187
V45	6DJ8	154-187
V114	6AU6	154-022
V122	T12G, Diode	152-008
V125	6AU6	154-022
V132	T12G, Diode	152-008
V133	6DJ8	154-187
V135	6DJ8	154-187
V145	12BY7	154-047
V152	12AL5	Use *157-075
V161	12AU6	154-040
V173	6DJ8	154-187
V183	6DJ8	154-187
V193	6DJ8	154-187

# Type 22 Mechanical Parts List

	Tektronix Part Number
BRACKET, CHASSIS SUPPORT	406-425
BRACKET, TIME/CM SWITCH	406-489
BUSHING, $\frac{3}{8}$ -32 x $\frac{9}{16}$ x .412	358-010
BUSHING, PANEL, $\frac{3}{8}$ -32 x $1\frac{13}{32}$ x .252	358-029
BUSHING, NYLON, FOR 5-WAY BINDING POST	358-036
CABLE, HARNESS, SWEEP #1	179-286
CABLE, HARNESS, SWEEP #2	179-287
CHASSIS	441-229
CLAMP, #20 WIRE FOR NEON BULB	343-043
CONNECTOR, CHASSIS MTD., 1 CONTACT, FEMALE, UHF (SN 101-4972)	131-081
CONNECTOR, CHASSIS MTD, BNC (SN 4973-up)	131-126
CONNECTOR, CHASSIS MTG.,32 CONTACT, MALE, AMPH.	131-096
COUPLING, POT	376-014
FOOT, WHITE NYLON	348-023
GROMMET, RUBBER, $\frac{1}{4}$	348-002
GROMMET, RUBBER, $\frac{5}{16}$	348-003
GROMMET, RUBBER, $\frac{3}{8}$	348-004
HOLDER, NEON BULB, SINGLE	352-008
KNOB, SMALL BLACK, $\frac{1}{4}$ HOLE PART WAY	366-033
KNOB, SMALL RED, $\frac{1}{4}$ HOLE PART WAY	366-038
KNOB, LARGE BLACK	366-058
KNOB, SMALL BLACK, W/HOLE THRU	366-070
LOCKWASHER, INT. #4	210-004
LOCKWASHER, INT. #6	210-006
LOCKWASHER, INT. #10	210-010
LOCKWASHER, INT. $\frac{1}{4}$	210-011
LOCKWASHER, INT., POT, $\frac{3}{8}$ x $\frac{1}{2}$	210-012
LOCKWASHER, INT., $\frac{3}{8}$ x $1\frac{1}{16}$	210-013
LOCKWASHER, SPRING, #5	210-017
LOCKWASHER, INT $\frac{1}{4}$	210-046
LUG, SOLDER, SE4	210-201
LUG, SOLDER, SE6 W/2 WIRE HOLES	210-202
LUG, SOLDER, SE10, LONG	210-206
LUG, SOLDER, POT, PLAIN, $\frac{3}{8}$	210-207
NUT, HEX, 4-40 x $\frac{3}{16}$	210-406
NUT, HEX, 6-32 x $\frac{1}{4}$	210-407

**Mechanical Parts List (continued)**

	Tektronix Part Number
NUT, HEX, $\frac{3}{8}$ -32 x $\frac{1}{2}$	210-413
NUT, HEX, $\frac{1}{4}$ -28 x $\frac{3}{8}$ x $\frac{3}{32}$	210-455
NUT, KEPS, 6-32 x $\frac{5}{16}$	210-457
NUT, HEX, $\frac{3}{8}$ -32 x $\frac{1}{2}$ x $\frac{11}{16}$	210-494
PANEL, FRONT	333-445
PLATE, SUBPANEL, FRONT	386-870
PLATE, REAR	387-570
POST, BINDING, 5-WAY	129-036
POST, BINDING, METAL ASS'Y	129-051
ROD, EXTENSION, NYLON, RED	384-179
ROD, EXTENSION, STEEL	384-183
ROD, FRAME, ALUMINUM (SN 101-650)	348-515
ROD, FRAME, BRASS W/CHROME PLATE (SN 651-up)	348-566
ROD, DELRIN, $\frac{5}{16}$ x $1\frac{5}{16}$ W/2 #44 CROSS HOLES	385-135
SCREW, 4-40 x $\frac{5}{16}$ BHS	211-011
SCREW, 4-40 x $\frac{3}{8}$ BHS	211-012
SCREW, 4-40 x 1 FHS	211-031
SCREW, 4-40 x $\frac{5}{16}$ FHS, PHILLIPS	211-038
SCREW, 6-32 x $\frac{5}{16}$ BHS	211-507
SCREW, 6-32 x $\frac{5}{16}$ FHS, 100°, CSK, PHILLIPS	211-538
SCREW, 8-32 x $\frac{1}{2}$ FHS, 100°, PHILLIPS	212-043
SCREW, 8-32 x $\frac{1}{2}$ RHS, PHILLIPS	212-044
SCREW, 5-32 x $\frac{3}{16}$ PAN HS, THREAD CUTTING	213-044
SOCKET, STM7G	136-008
SOCKET, STM9G	136-015
SPACER, NYLON, $\frac{3}{16}$ , FOR CERAMIC STRIP	361-008
STRIP, CERAMIC, $\frac{3}{4}$ x 9 NOTCHES, CLIP MTD.	124-090
STRIP, CERAMIC, $\frac{3}{4}$ x 9 NOTCHES, CLIP MTD.	124-091
TAG, SN INSERT	334-679
WASHER, STEEL, 6L x $\frac{3}{8}$ x .032	210-803
WASHER, STEEL, 8S x $\frac{3}{8}$ x .032	210-804

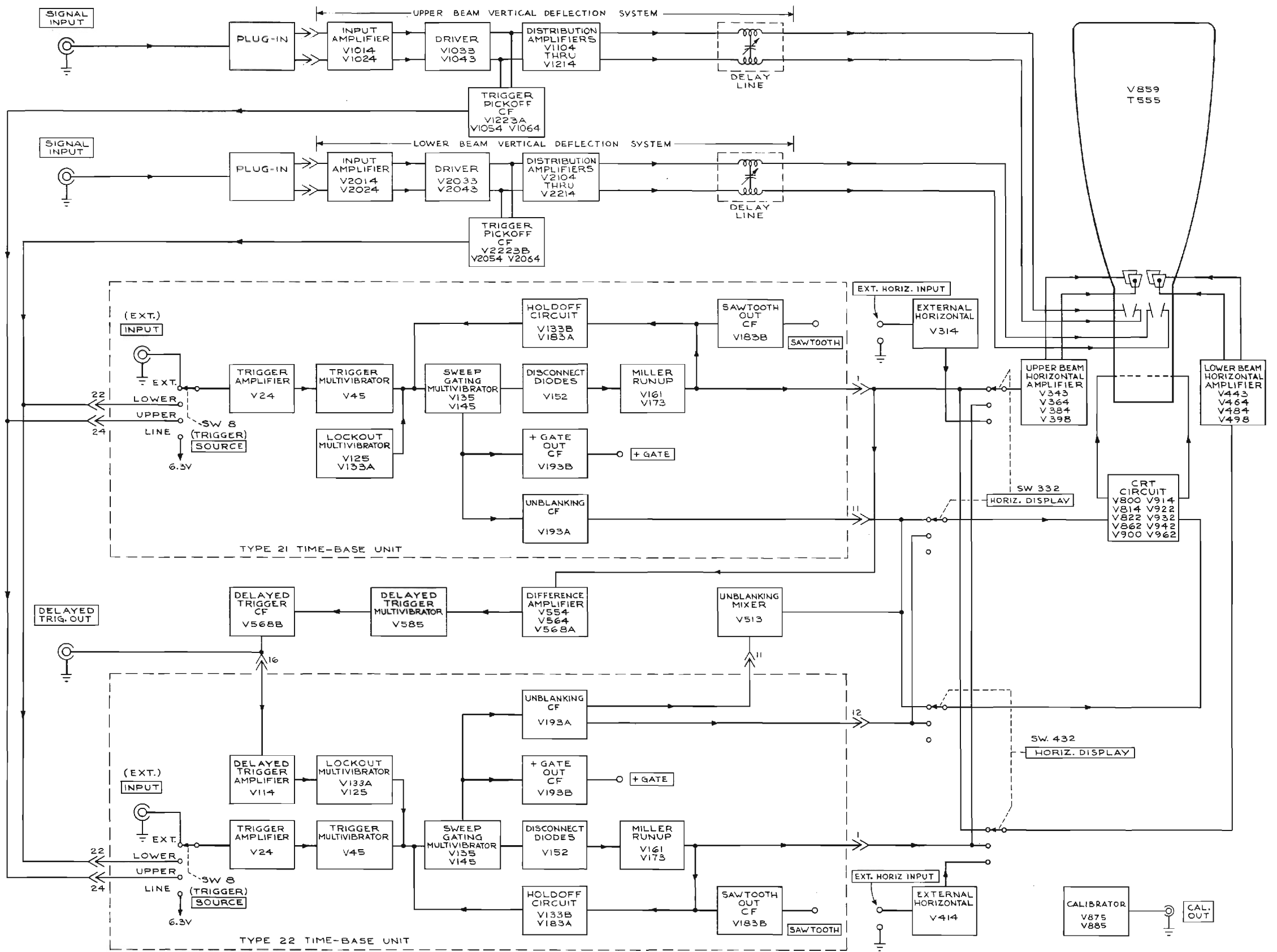

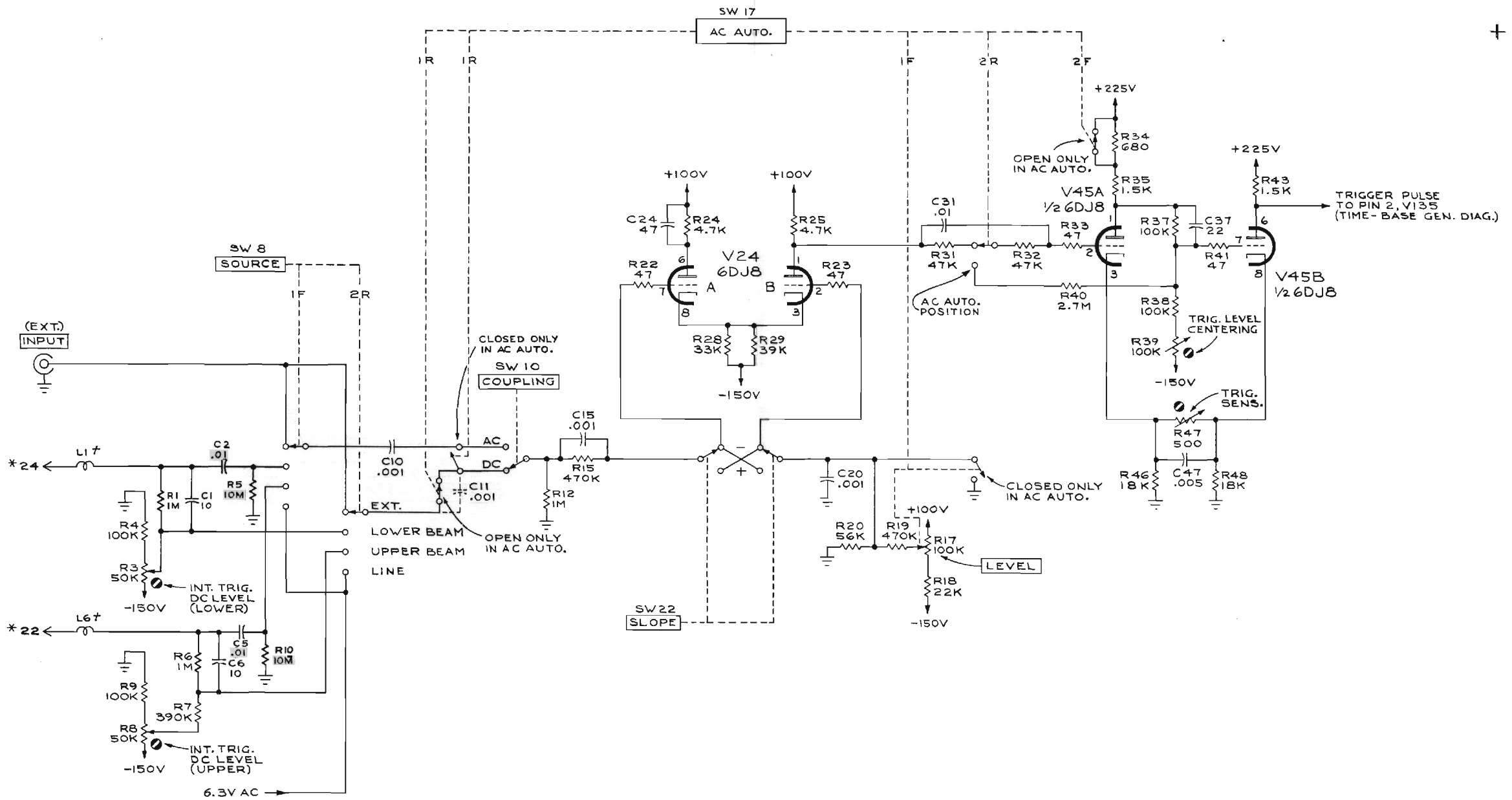

NOTE:  
 \* INDICATES PINS ON INTERCONNECTING PLUG.  
 † FERRITE BEAD, PARASITIC SUPPRESSOR.

TYPE 21 TIME-BASE UNIT  
 TYPE 22 TIME-BASE UNIT

SEE PARTS LIST FOR EARLIER  
 VALUES AND S/N CHANGES OF  
 PARTS MARKED WITH RED  
 TINT BLOCKS

MH  
 363

TIME-BASE TRIGGER

CIRCUIT NUMBERS  
 1 THRU 49

D

+

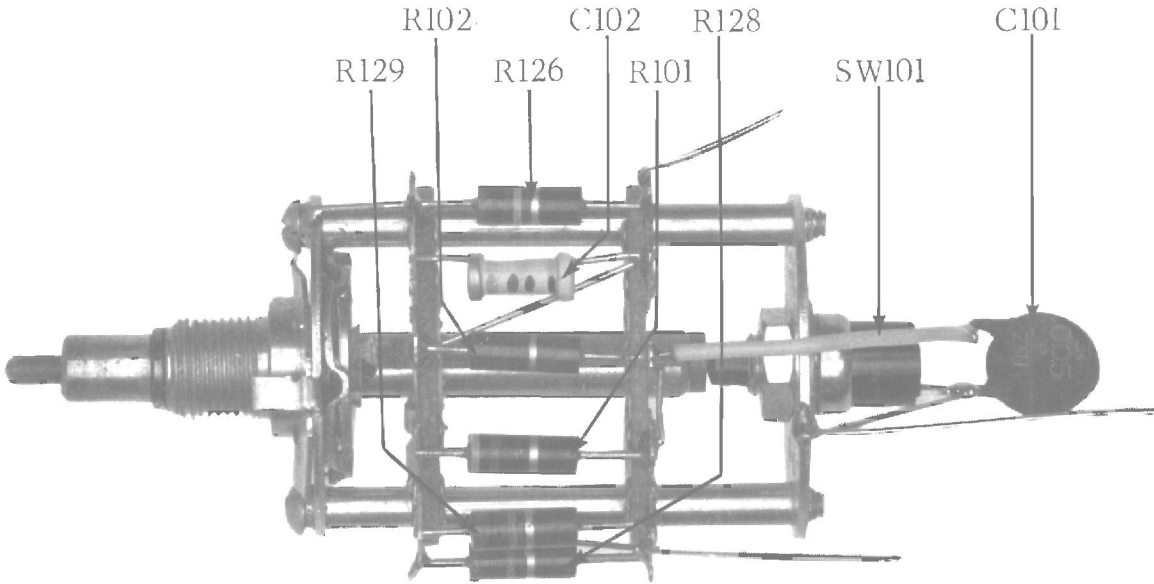

Type 21

## SWEEP FUNCTION

A

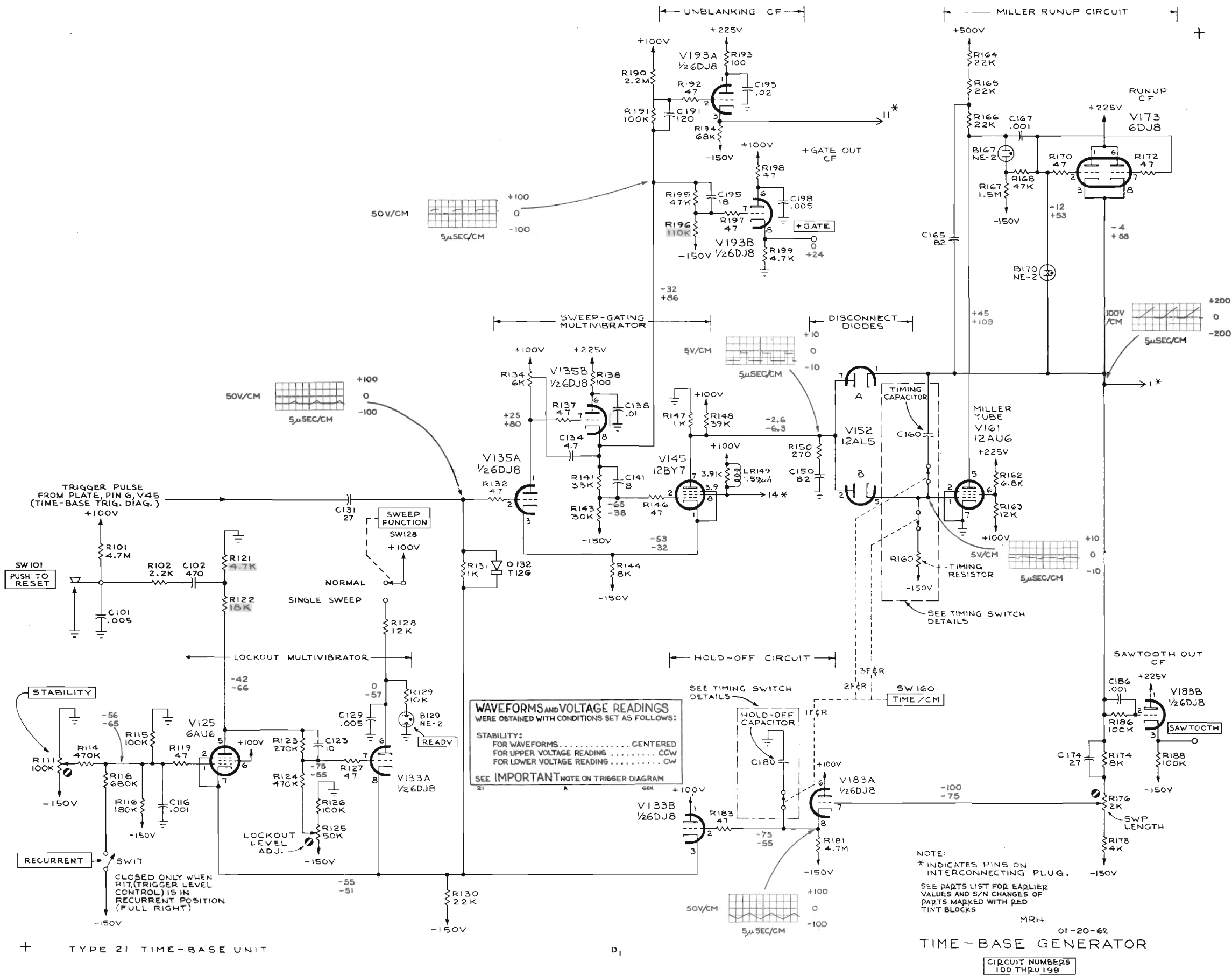

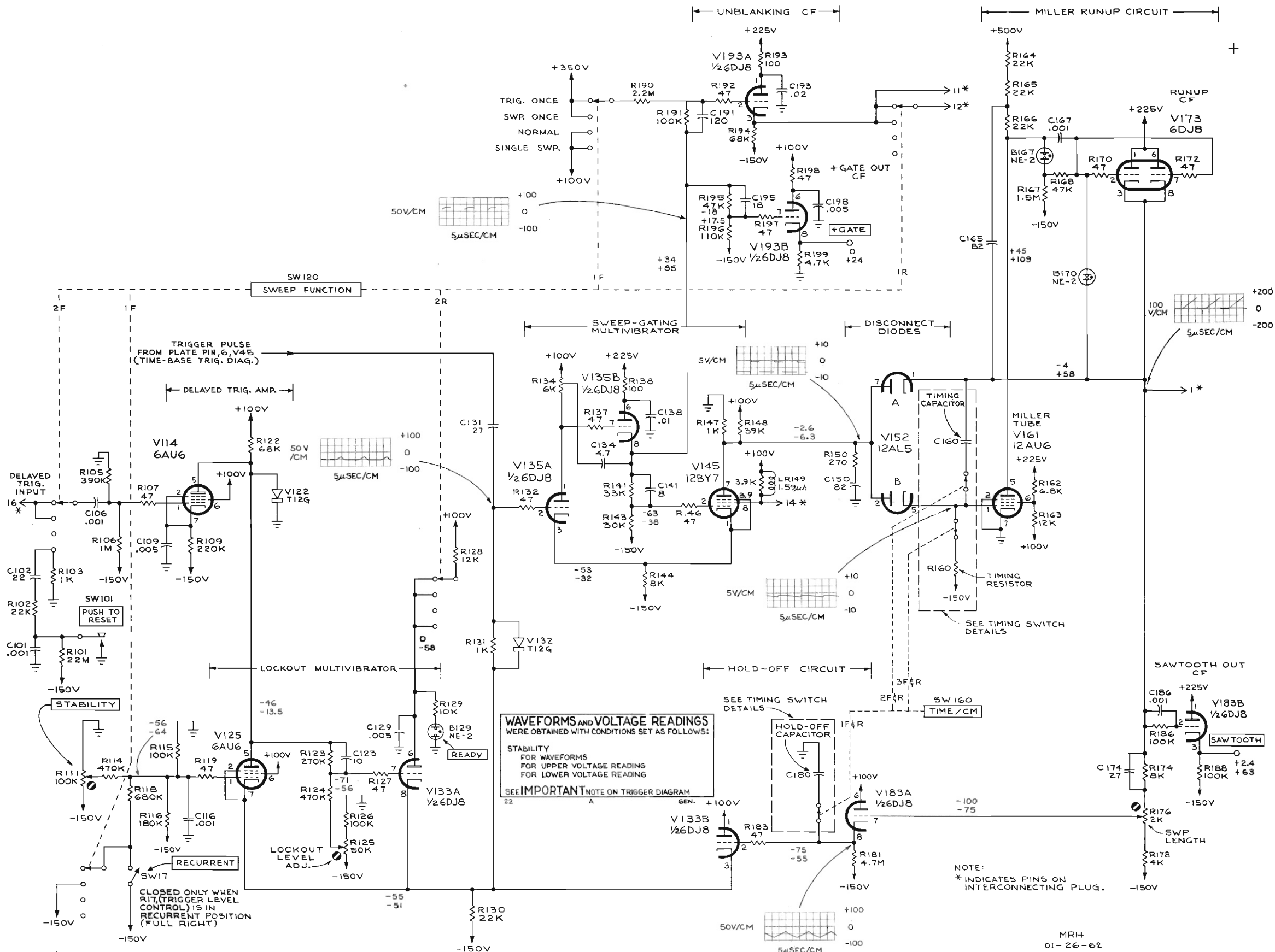

TYPE 22 TIME-BASE UNIT

A<sub>3</sub>

MRH 01-26-62  
 TIME-BASE GENERATOR

CIRCUIT NUMBERS  
 100 THRU 199

TO CATH., PIN 8, V183A  
HOLD-OFF CF  
(TIME-BASE GEN. DIAG.)

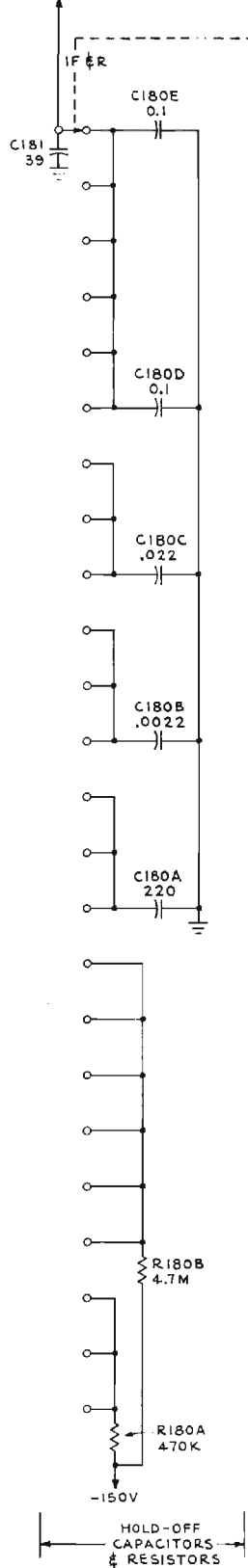

HOLD-OFF  
CAPACITORS  
& RESISTORS

TYPE 21 TIME-BASE UNIT  
TYPE 22 TIME-BASE UNIT

TO GRID, PIN 1, V161  
MILLER RUNUP TUBE  
(TIME-BASE GEN. DIAG.)

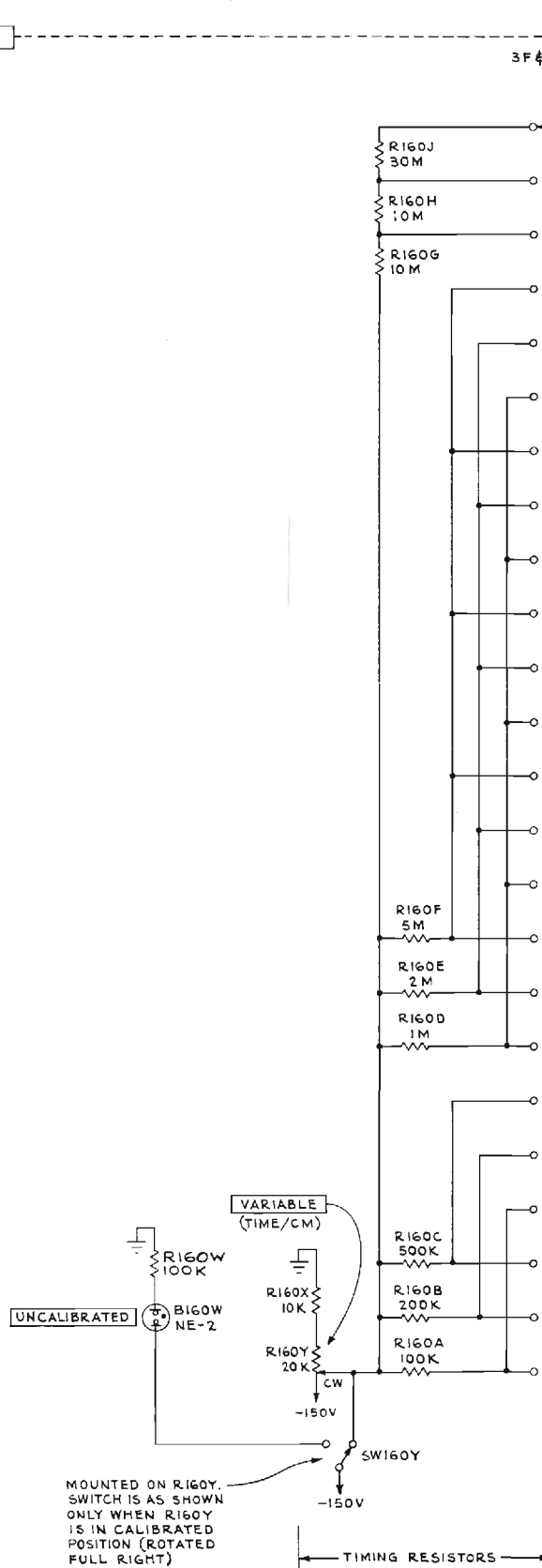

A<sub>2</sub>

TO CATH., PINS 3 & 8, V173  
RUNUP CF  
(TIME-BASE GEN. DIAG.)

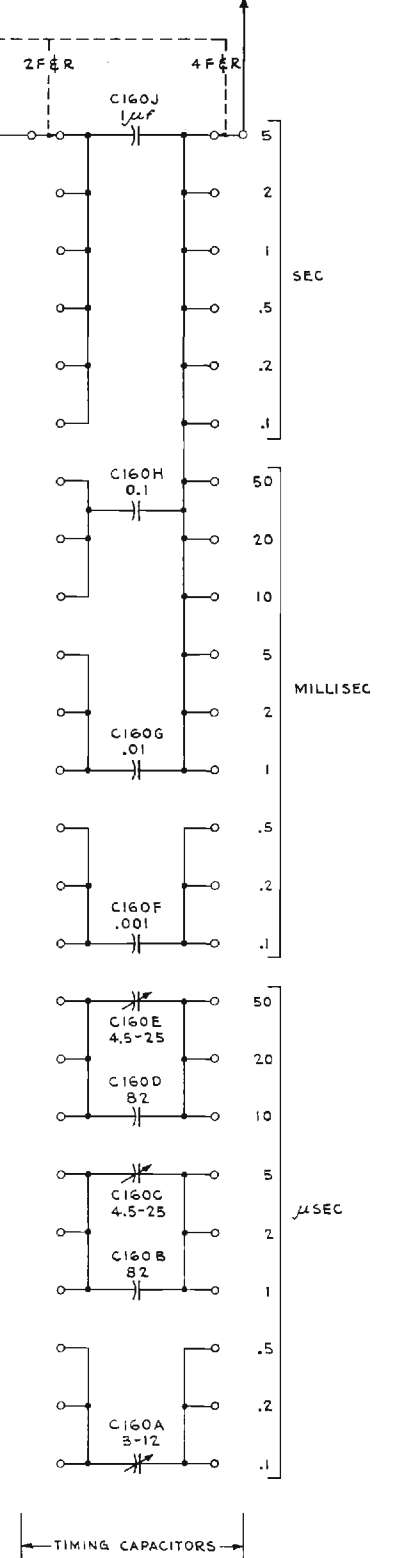

RBH  
1-5-62

TIMING SWITCH

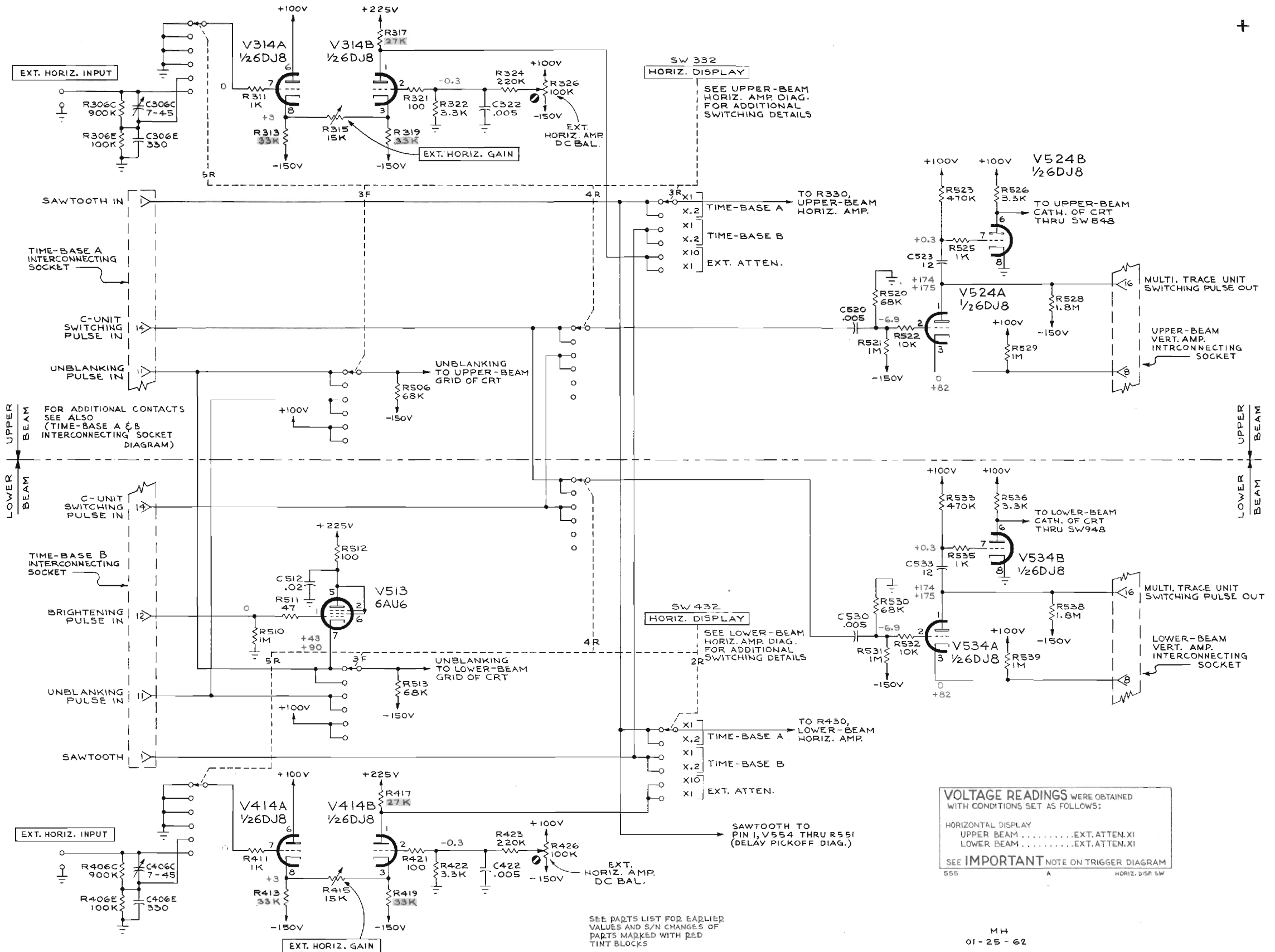

TYPE 555 OSCILLOSCOPE

B

HORIZONTAL DISPLAY SWITCHING

CIRCUIT NUMBERS  
305 THRU 326  
505 THRU 539



INPUT  
C.F.

DRIVER  
C.F.

OUTPUT  
AMPLIFIER

OUTPUT C.F.  
HF CAPACITANCE  
DRIVER

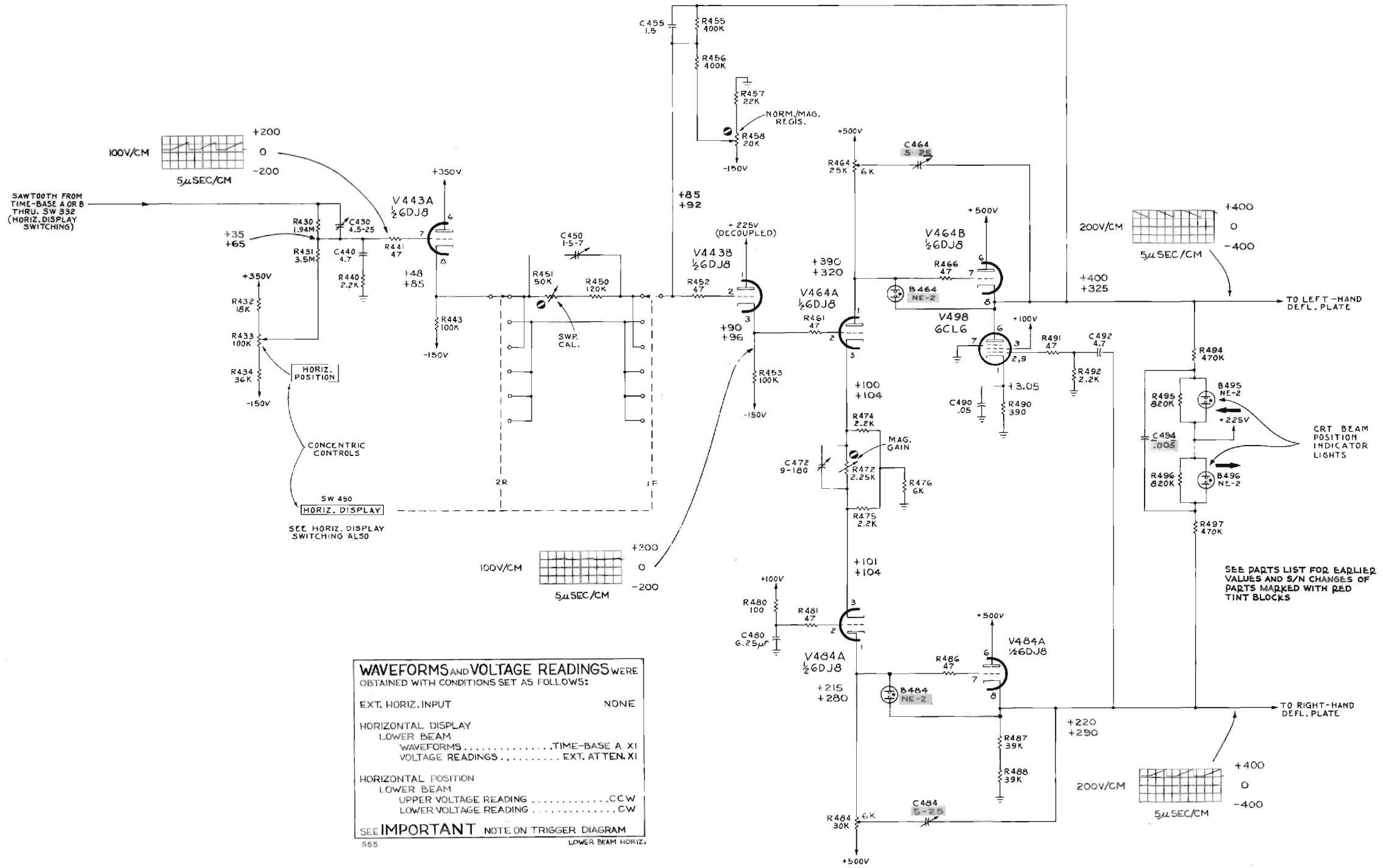

WAVEFORMS AND VOLTAGE READINGS WERE OBTAINED WITH CONDITIONS SET AS FOLLOWS:

EXT. HORIZ. INPUT	NONE
HORIZONTAL DISPLAY	
LOWER BEAM	
WAVEFORMS	TIME-BASE A XI
VOLTAGE READINGS	EXT. ATTEN. XI
HORIZONTAL POSITION	
LOWER BEAM	
UPPER VOLTAGE READING	CCW
LOWER VOLTAGE READING	CW

SEE IMPORTANT NOTE ON TRIGGER DIAGRAM

555 LOWER BEAM HORIZ.

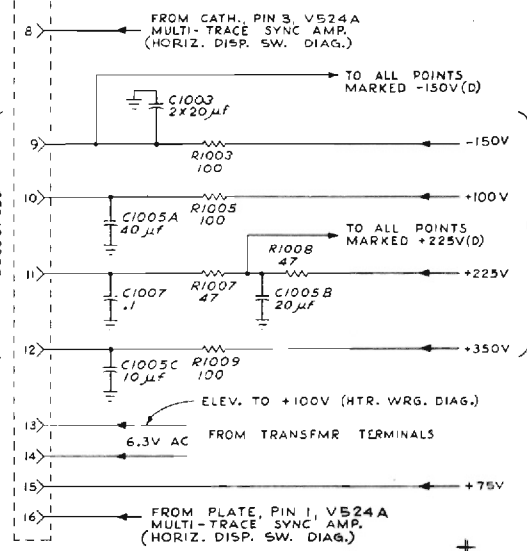
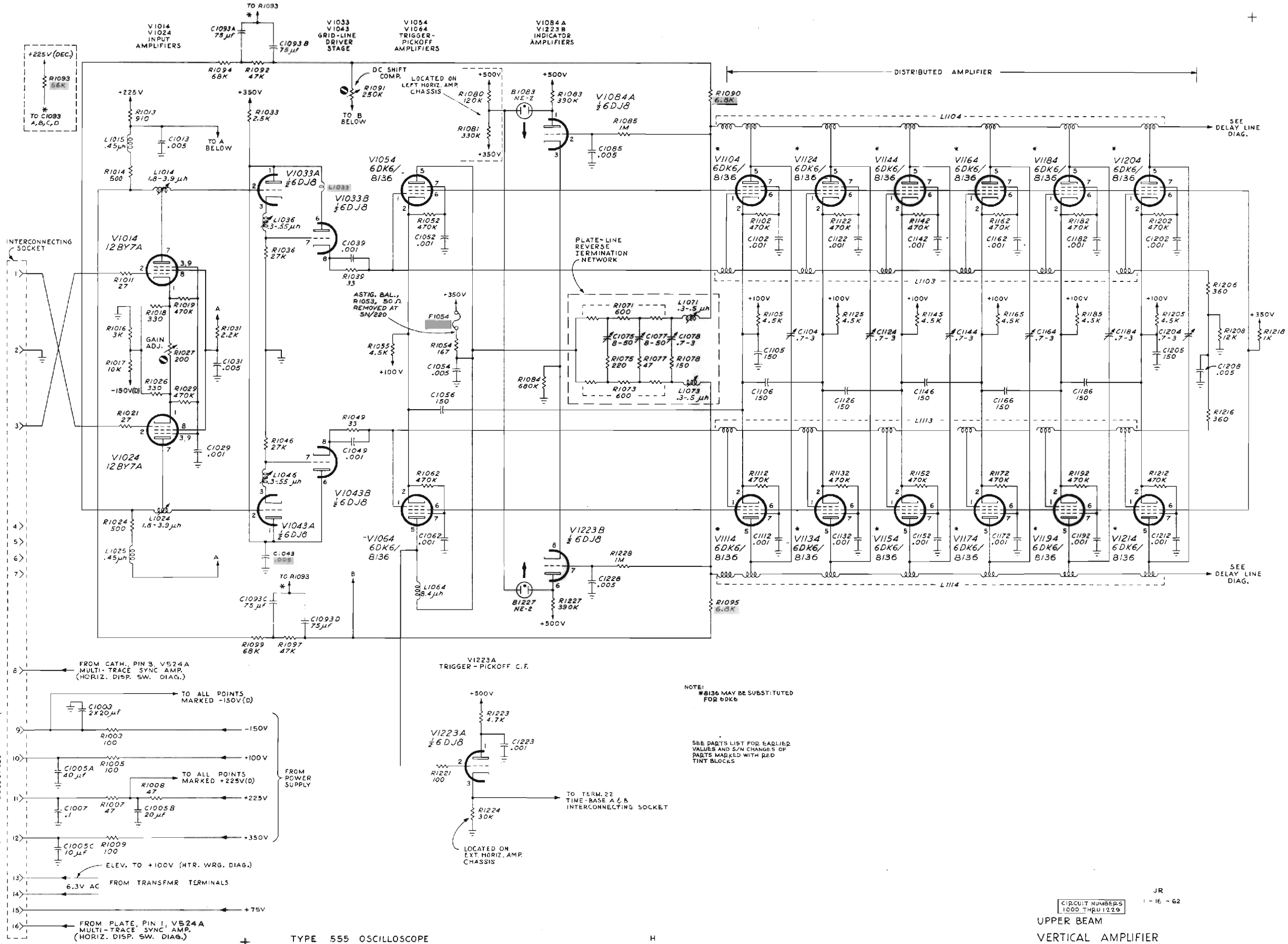

TYPE 555 OSCILLOSCOPE

H

JR  
CIRCUIT NUMBERS 1000 THRU 1229  
UPPER BEAM  
VERTICAL AMPLIFIER

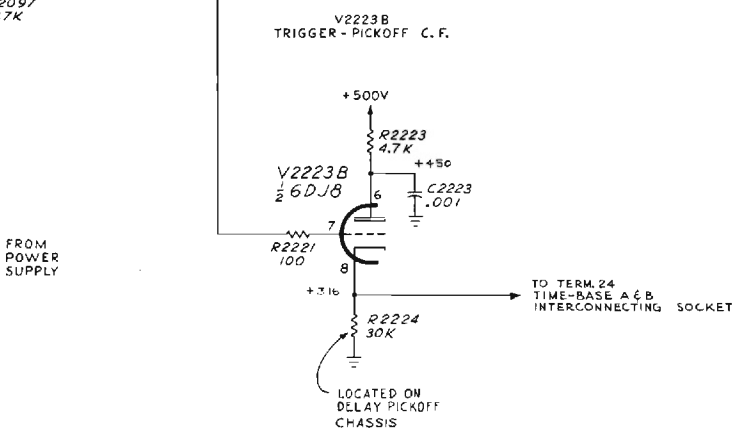
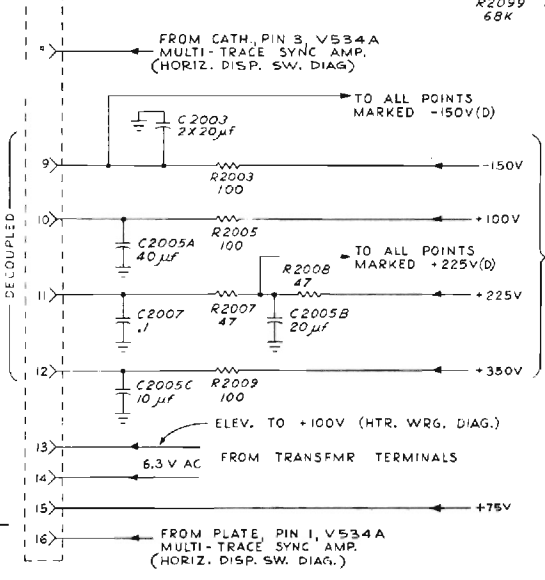
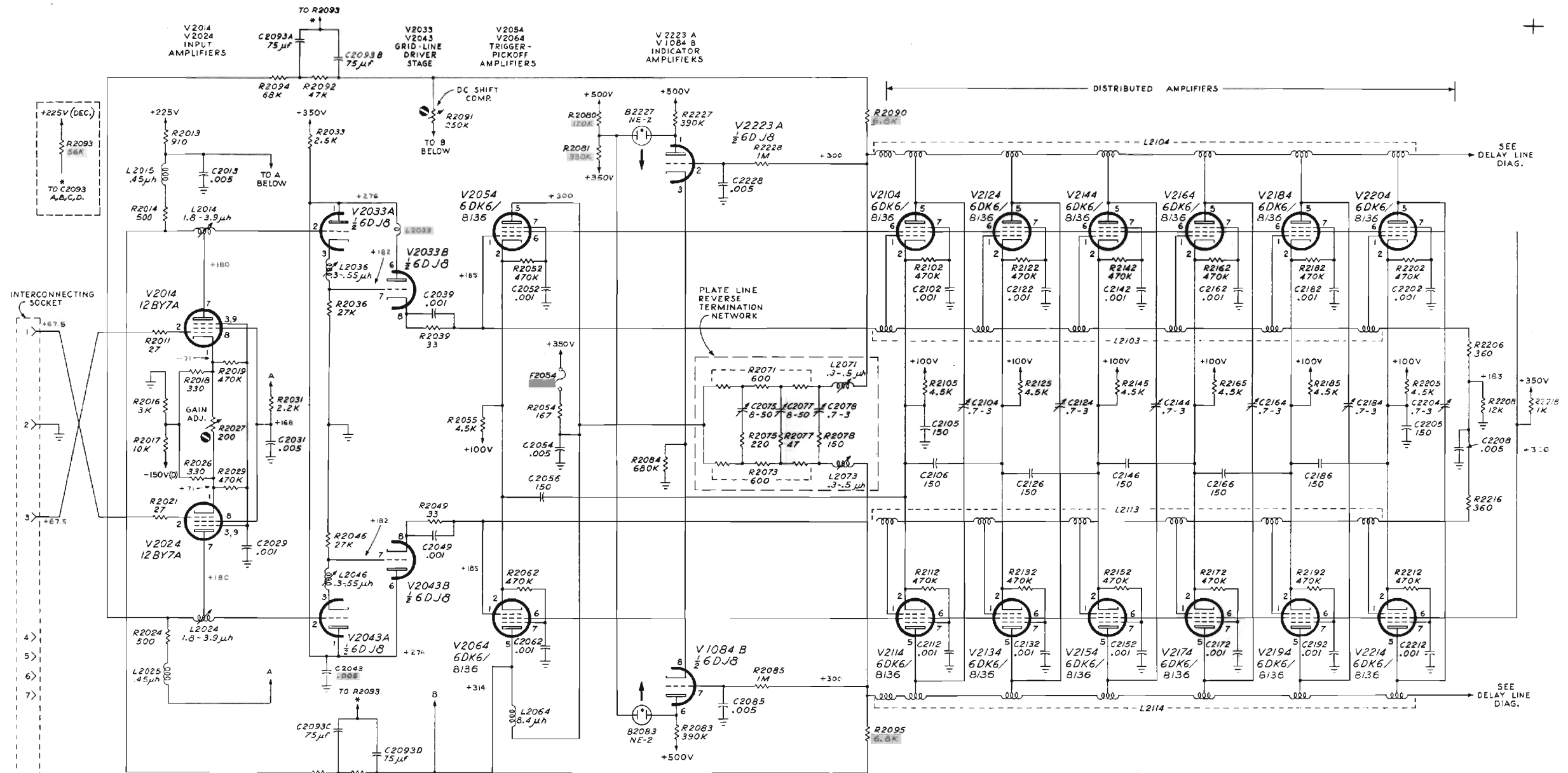

VOLTAGE READINGS WERE OBTAINED WITH CONTROLS SET AS FOLLOWS:

INPUT SIGNAL ..... NONE  
 TRIGGER MODE ..... AUTO.  
 POSITION ..... TRACE CENTERED

SEE ALSO IMPORTANT NOTE ON TIME-BASE TRIGGER DIAGRAM

SEE PARTS LIST FOR EARLIER VALUES AND S/N CHANGES OF PARTS MARKED WITH RED TINT BLOCKS

JR

01-15-62

TYPE 555 OSCILLOSCOPE

H1

LOWER BEAM

VERTICAL AMPLIFIER

CIRCUIT NUMBERS 2000 THRU 2229

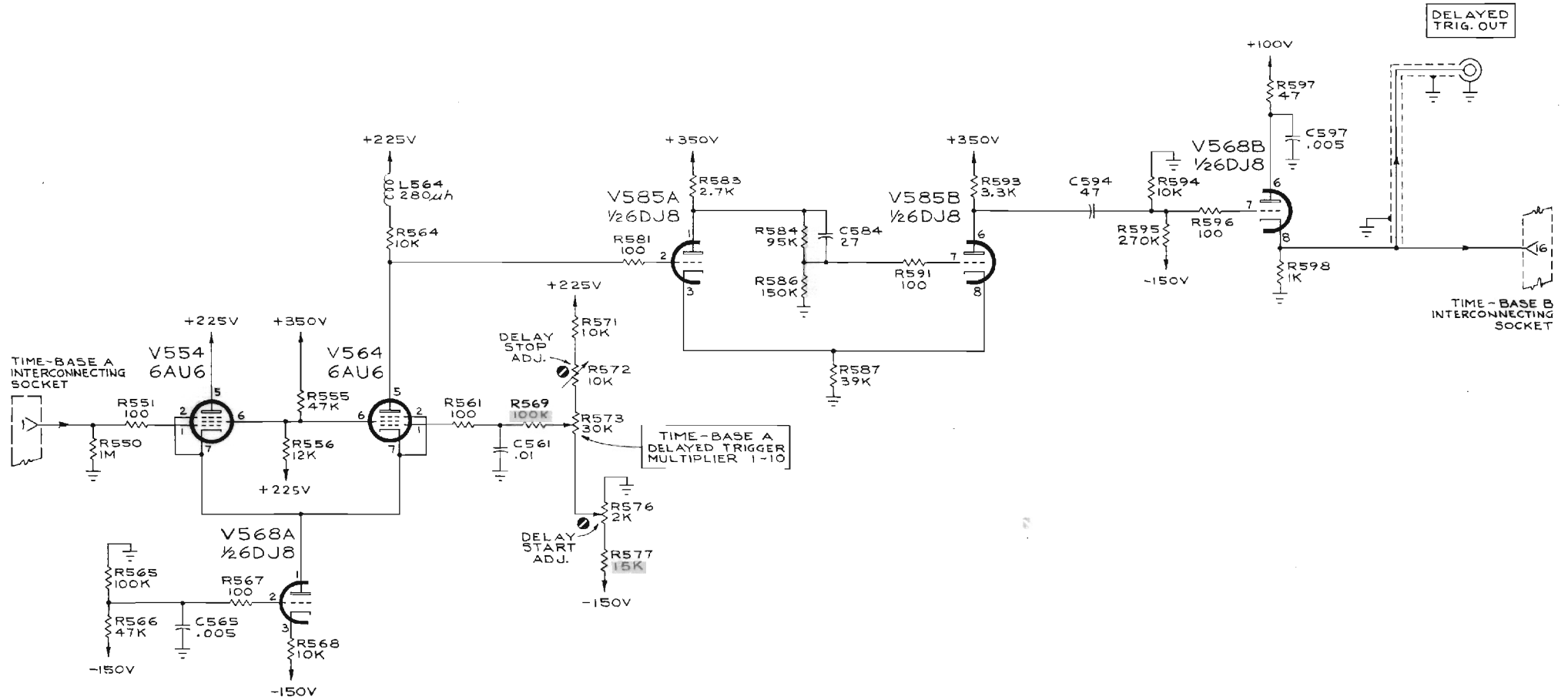

TYPE 555 OSCILLOSCOPE

C<sub>1</sub>

MH  
01-14-62  
DELAY PICKOFF

CIRCUIT NUMBERS  
550 THRU 599

SEE PARTS LIST FOR EARLIER  
VALUES AND S/N CHANGES OF  
PARTS MARKED WITH RED  
TINT BLOCKS

+

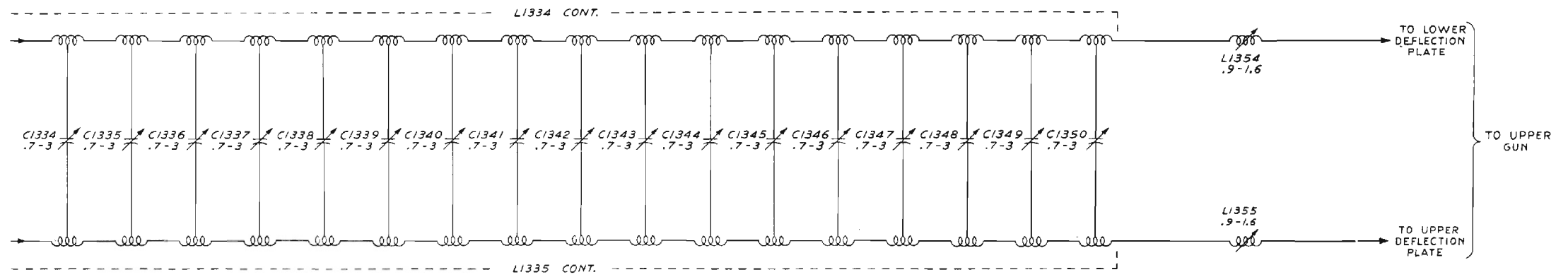
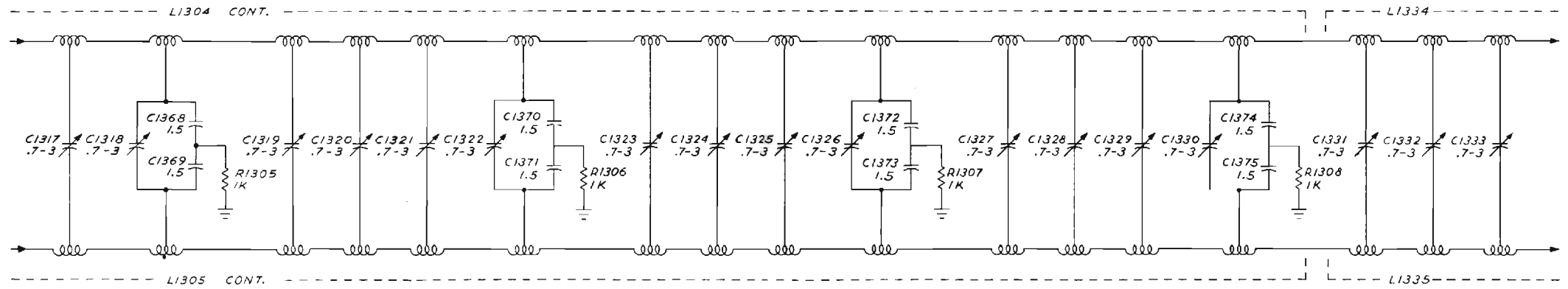
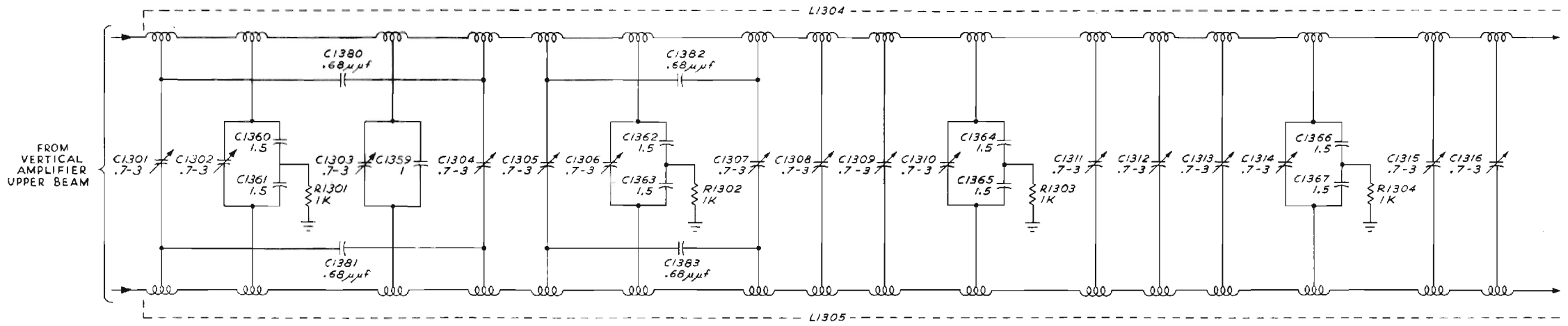

01-20-62 JR  
GAB

UPPER BEAM

DELAY LINE NETWORK

CIRCUIT NUMBERS  
1300 THRU 1355

TYPE 555 OSCILLOSCOPE

A<sub>1</sub>

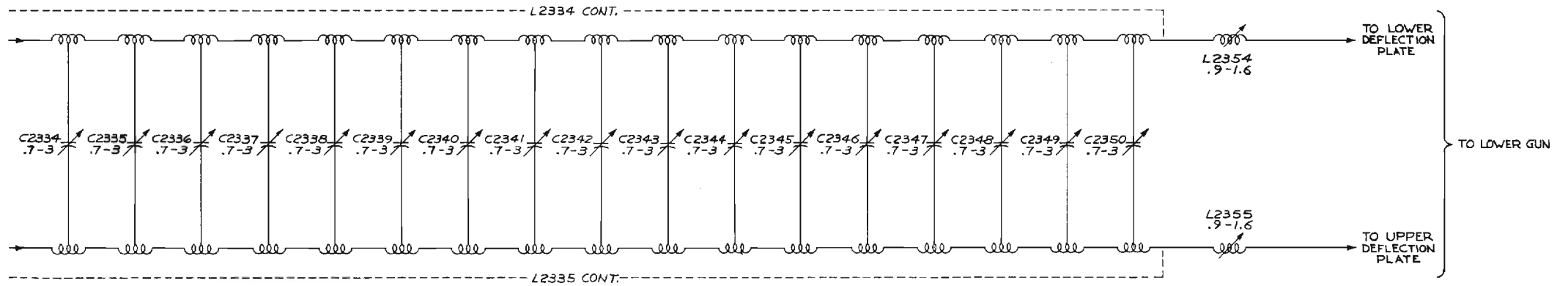
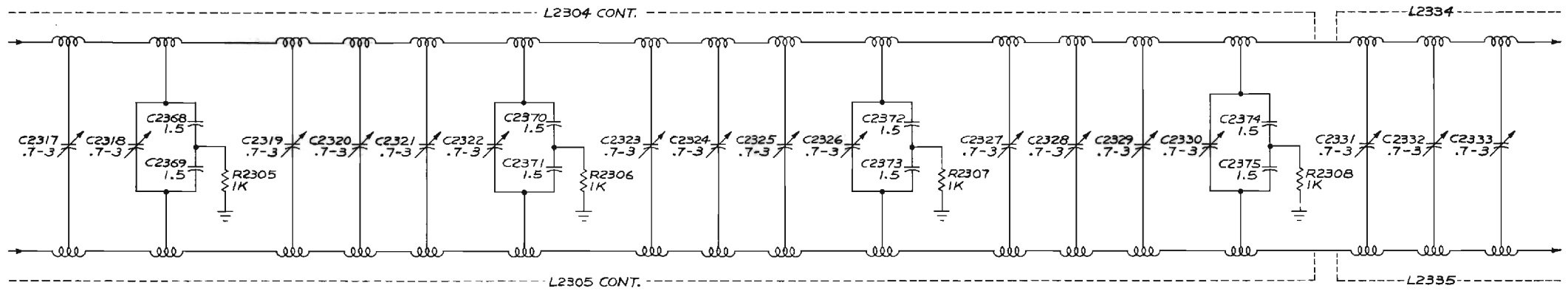
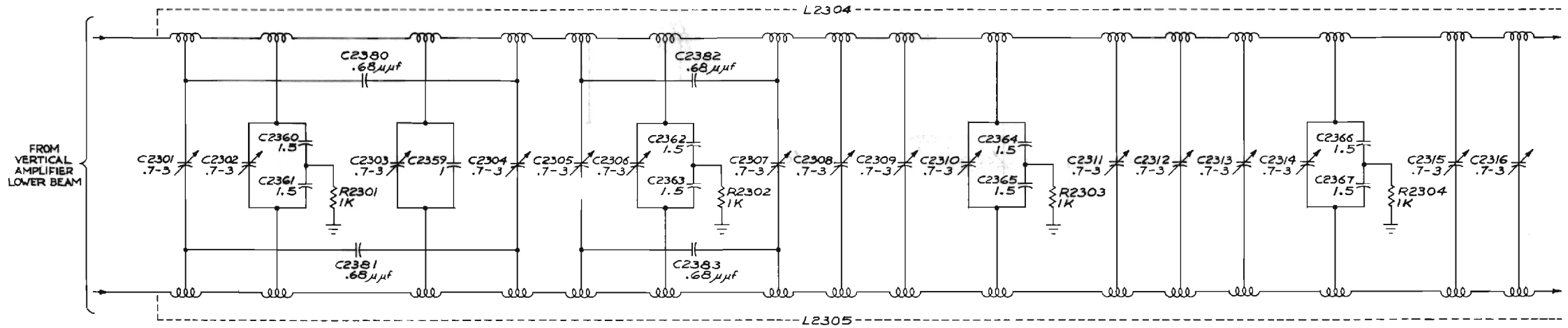

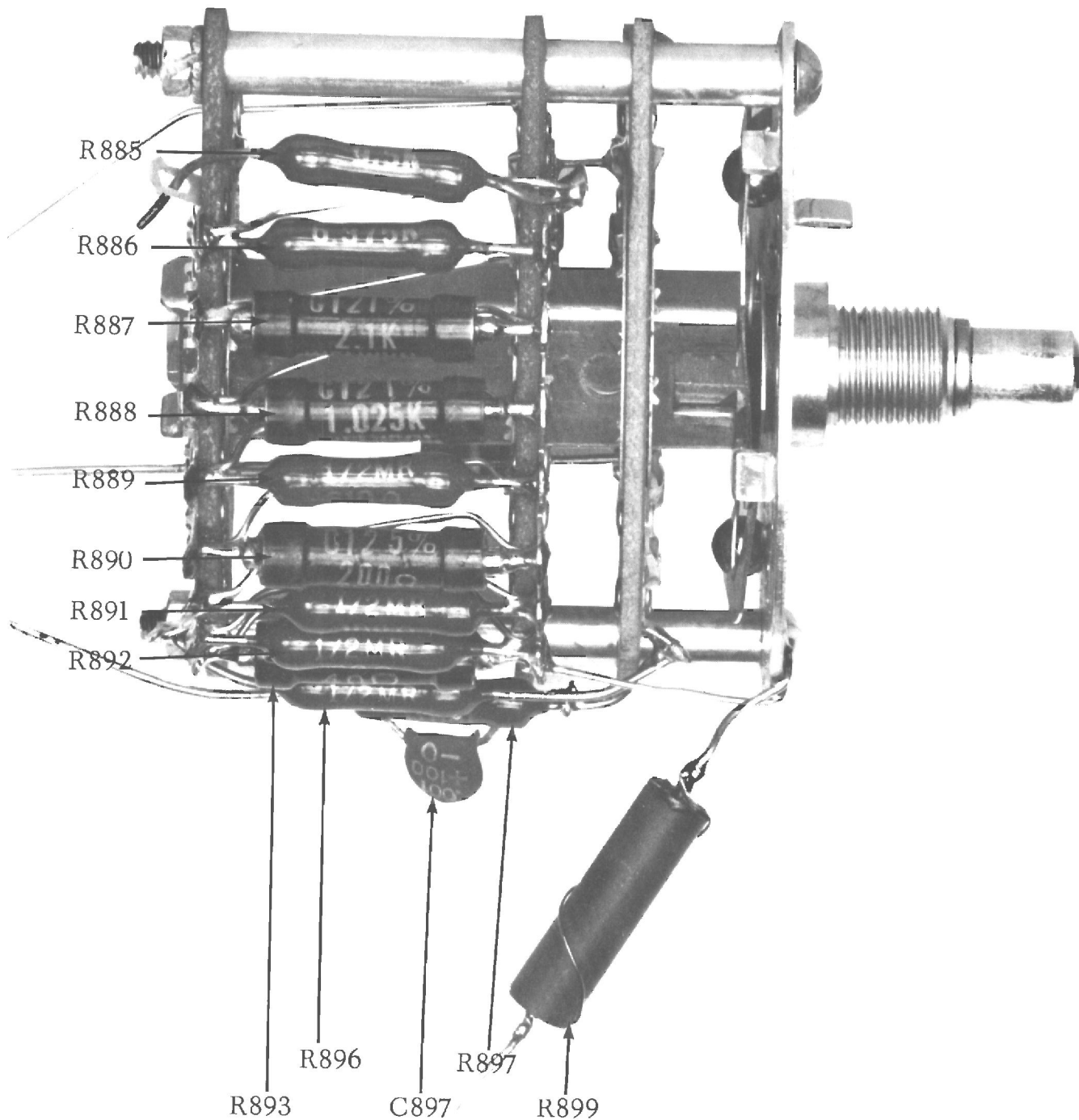

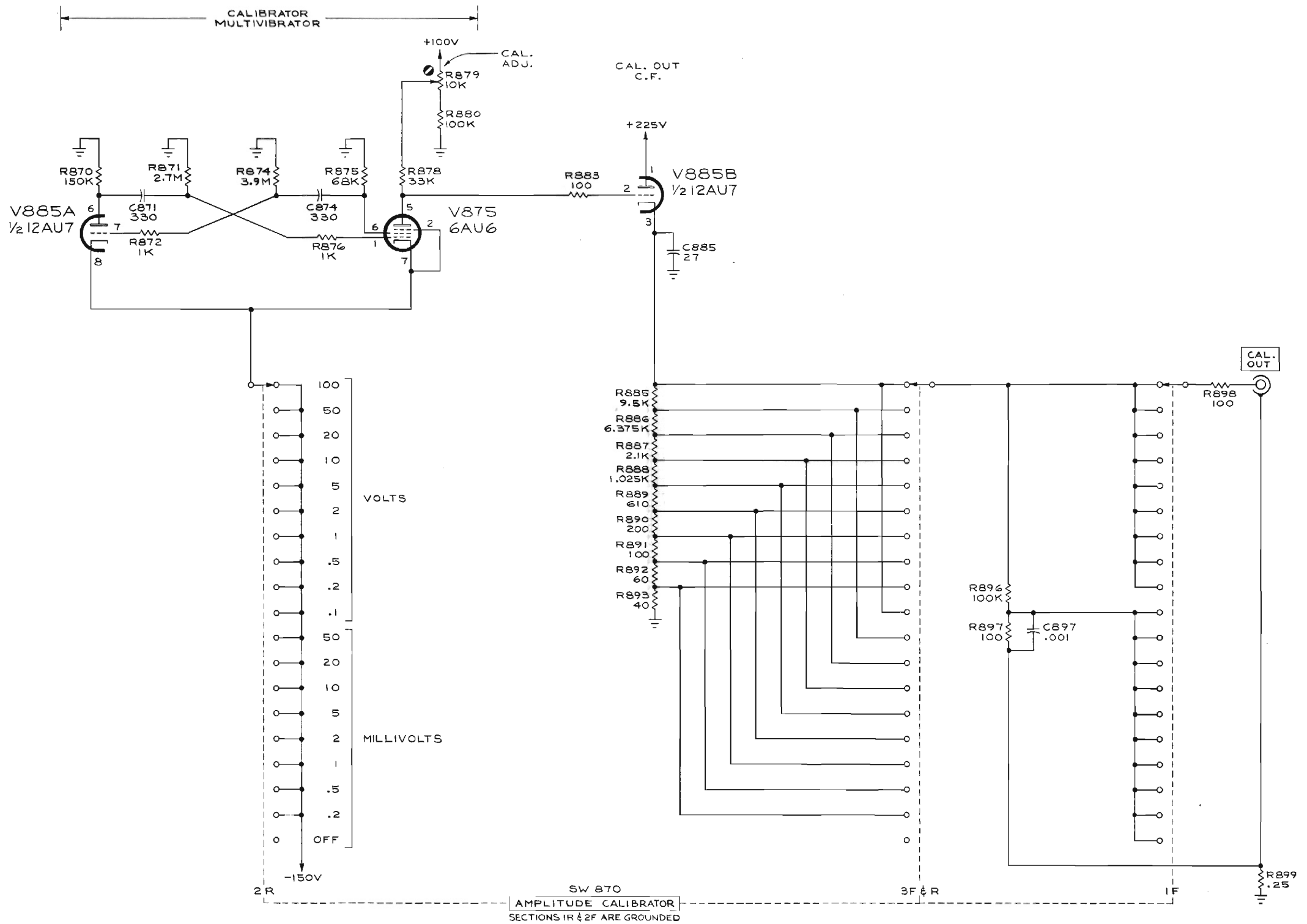

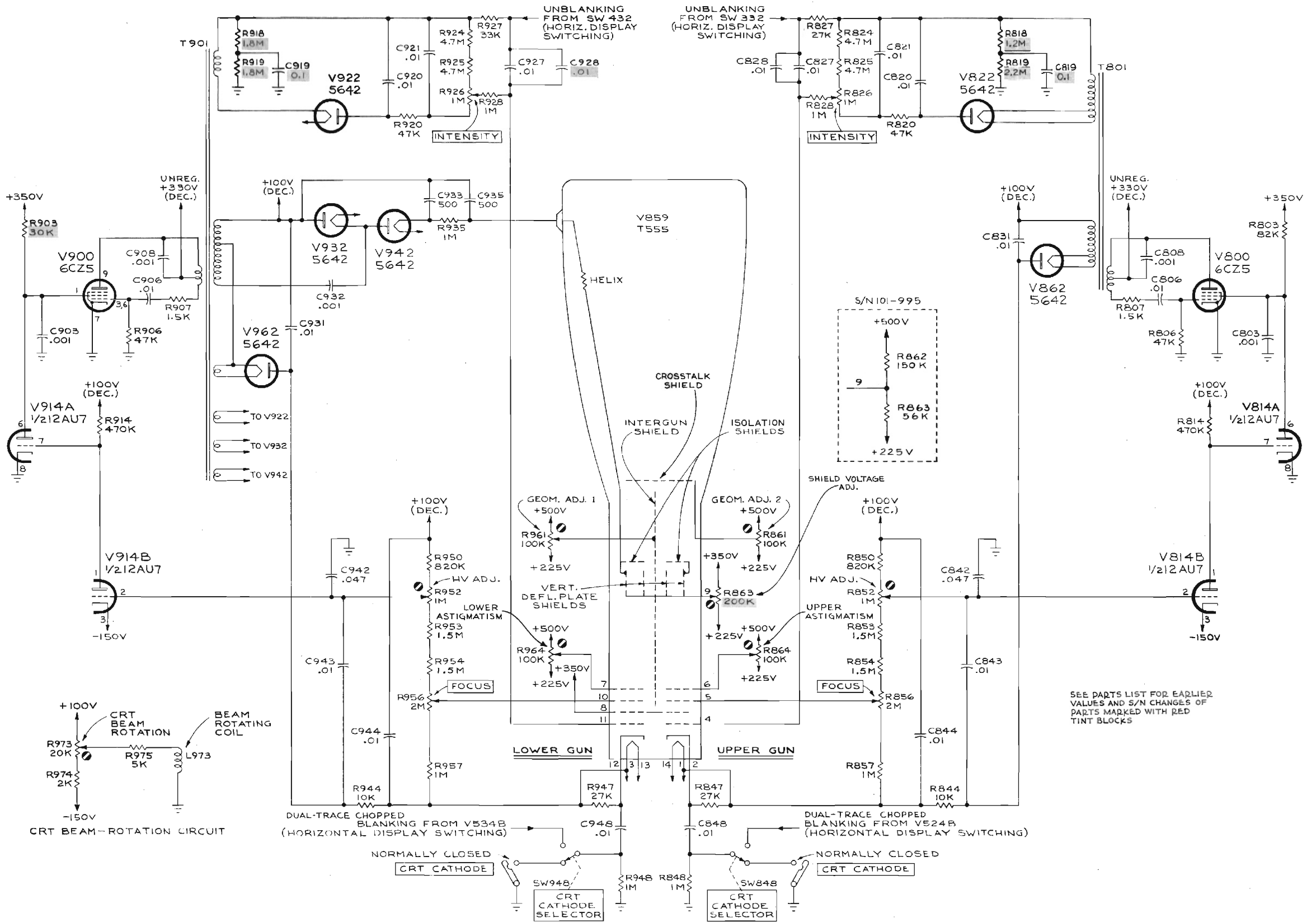

SEE PARTS LIST FOR EARLIER VALUES AND S/N CHANGES OF PARTS MARKED WITH RED TINT BLOCKS

TYPE 555 OSCILLOSCOPE

E<sub>3</sub>

CRT CIRCUIT

CIRCUIT NUMBERS 900 THRU 975

MH  
01-28-62

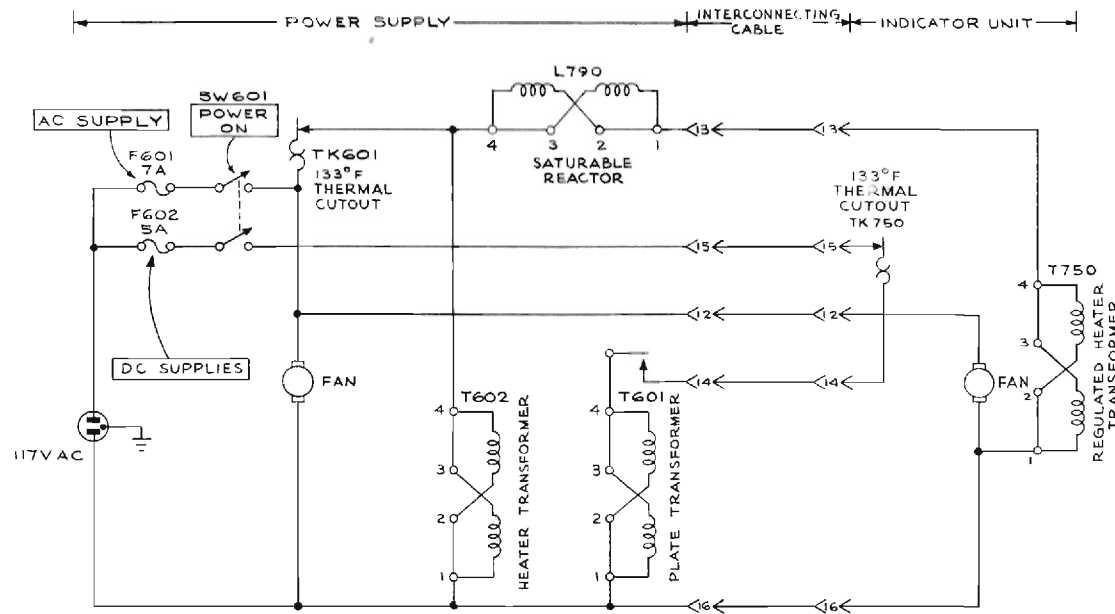

117V AC WIRING DIAGRAM

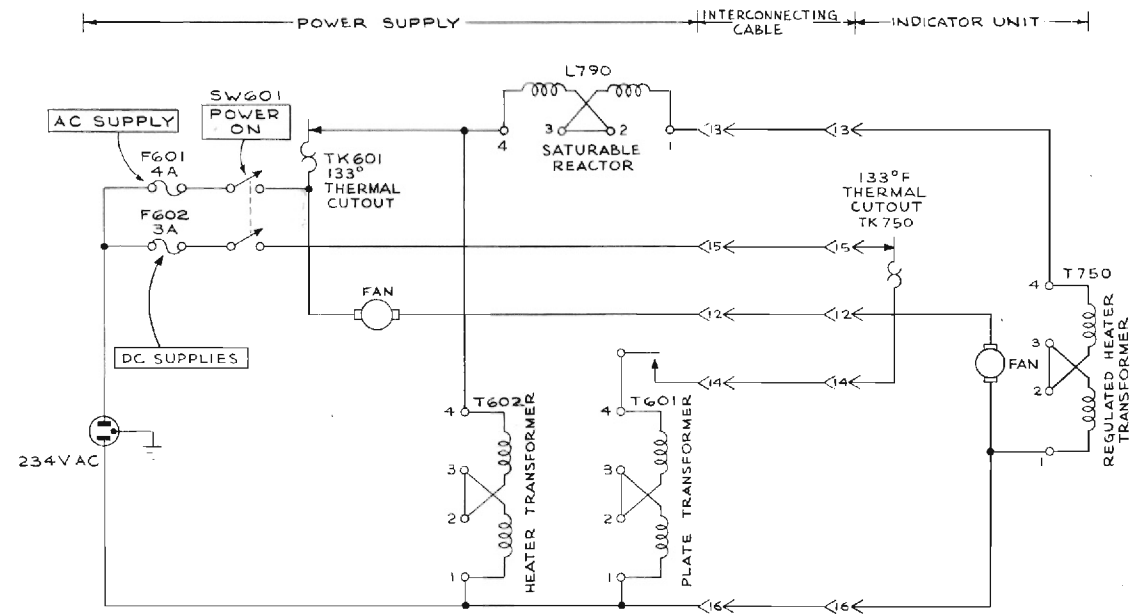

234V AC WIRING DIAGRAM

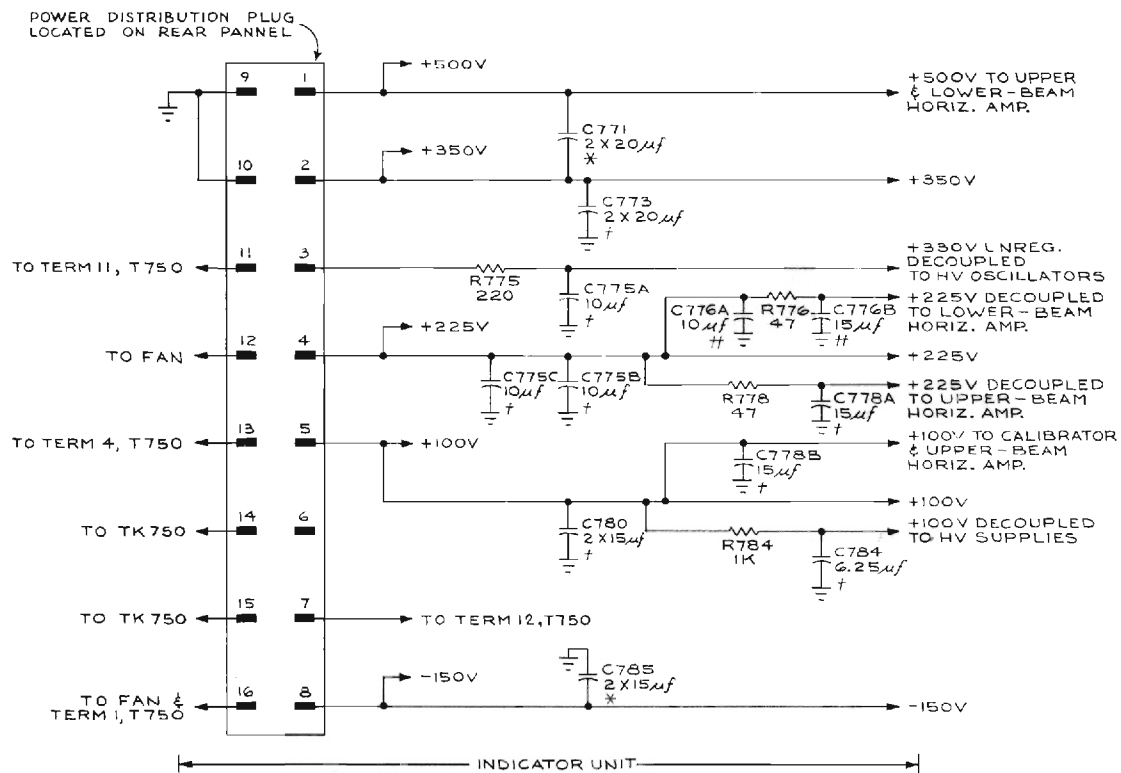

NOTE:  
 \* LOCATED ON BULKHEAD  
 † LOCATED ON UPPER BEAM HORIZ. AMP. CHASSIS  
 ‡ LOCATED ON LOWER BEAM HORIZ. AMP. CHASSIS

DECOUPLING NETWORKS

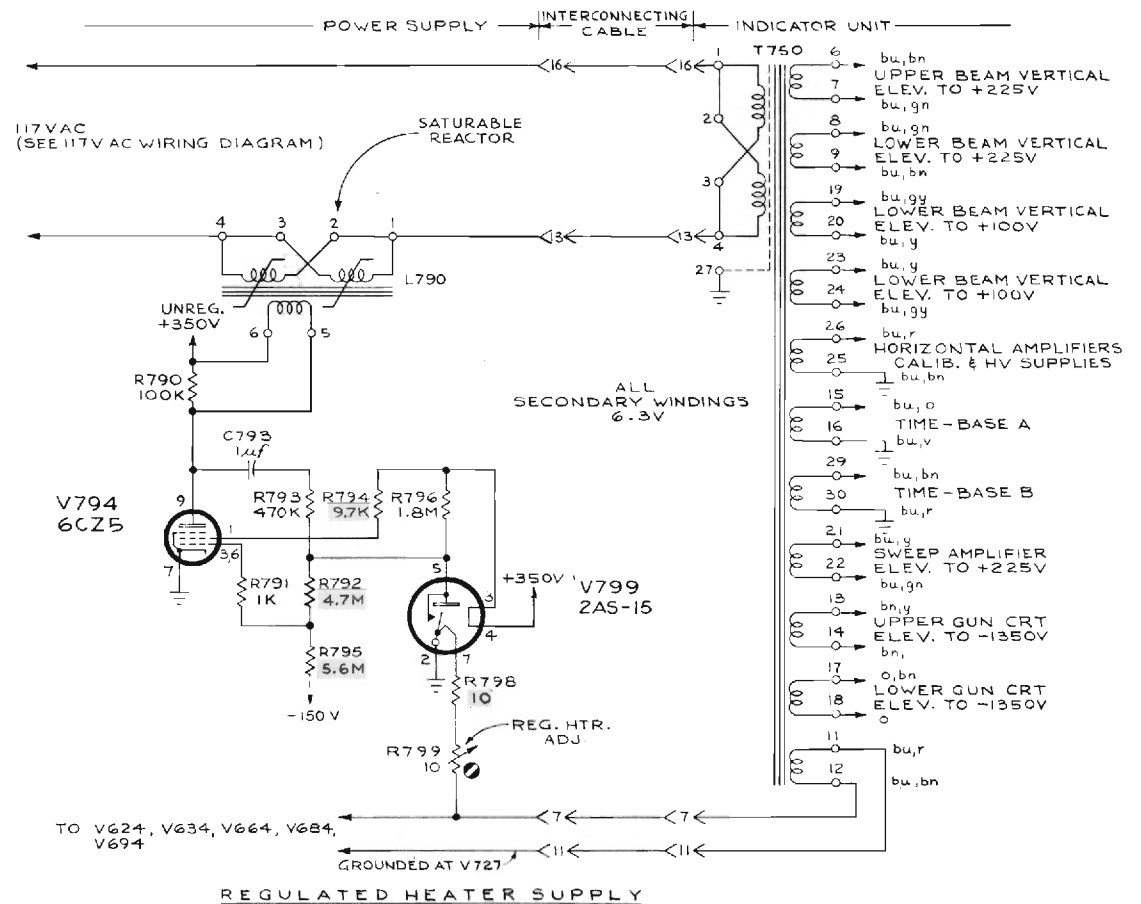

REGULATED HEATER SUPPLY

SEE PARTS LIST FOR EARLIER VALUES AND S/N CHANGES OF PARTS MARKED WITH RED TINT BLOCKS

M14  
01-28-62

AC WIRING DIAGRAMS  
 DECOUPLING NETWORKS  
 REGULATED HEATER SUPPLY

CIRCUIT NUMBERS  
 770 THRU 799



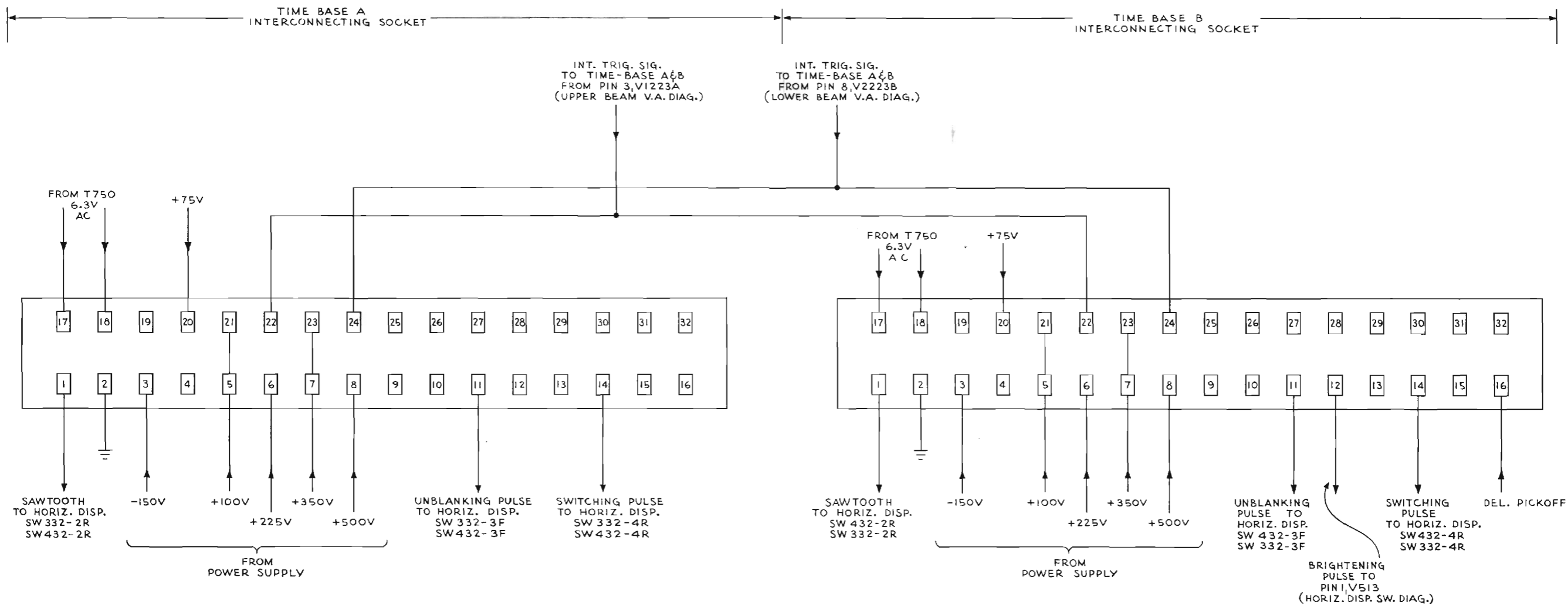

G.A.B.  
01-7-62

TYPE 555 OSCILLOSCOPE

B<sub>1</sub>

TIME-BASE A & B INTERCONNECTING SOCKETS

TYPE 555

Accessories List

P6000 Probe	Change to	P6006 Probe		010-127
A510 Binding Post Adapter		Change to	BNC	103-033

TYPE 555- TENT. S/N 7000 (INSERT CORRECTION)

PARTS LIST CORRECTION

CHANGE TO:

R335	33k	2w	fixed	comp	10%	306-333
R338	15k	1w	fixed	comp	10%	304-153
R435	33k	2w	fixed	comp	10%	306-333
R438	15k	1w	fixed	comp	10%	304-153

C7225/963

TYPE 21A and 22A - TENT. S/N 7000 (INSERT CORRECTION)

PARTS LIST CORRECTION

ADD

C119      283-001      .005 $\mu$ f      Disc Type 500v

SCHEMATIC CORRECTION

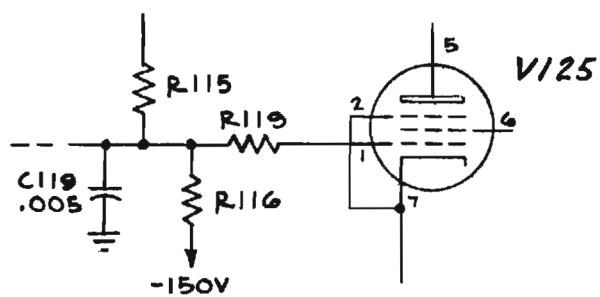

PART. 21A & 22A  
GEN. DIAG.

C7114/963

TYPE 21A and 22A - TENT. S/N 7000

### PARTS LIST CORRECTIONS

CHANGE TO:

R100	302-393	39k	1/2w	10%
SW120	260-556	*262-628	Rotary	SWEEP FUNCTION

ADD

R98	316-101	100Ω	1/4w	10%
R99	316-680	68Ω	1/4w	10%

### SCHEMATIC CORRECTIONS

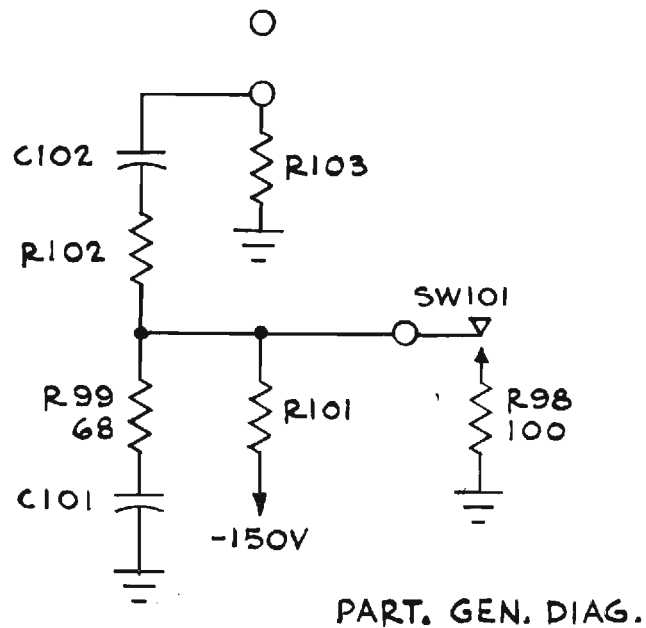

M7459/963

TYPE 21A - TENT. S/N 7500  
TYPE 22A - TENT. S/N 7500

PARTS LIST CORRECTIONS

CHANGE TO: .

Q104      151-071      2N1305

M7487/1263

TYPE 21A - TENT. S/N 7480

TYPE 22A - TENT. S/N 7480

PARTS LIST CORRECTIONS

CHANGE TO

L42      \*120-337    Toroid      TD-114      (365 $\mu$ h  $\pm$  5%)

M7589/1163